

Renegade

ET 180iP, ET 210iP

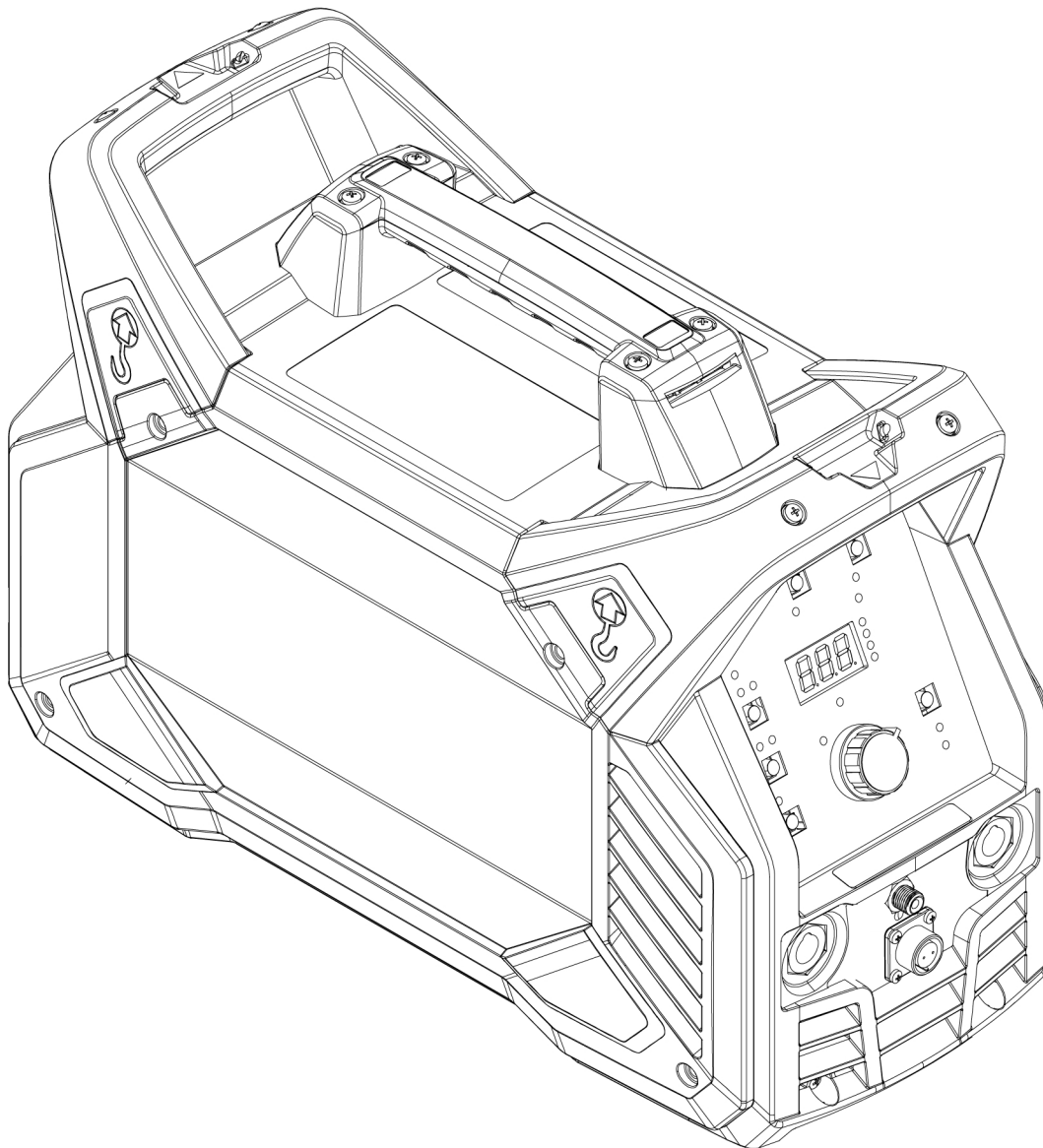

Instruction manual



EU DECLARATION OF CONFORMITY

According to:

The Low Voltage Directive 2014/35/EU; The EMC Directive 2014/30/EU;
The RoHS Directive 2011/65/EU; The Ecodesign Directive 2009/125/EC

Type of equipment

Arc welding power source

Type designation

ET 180iP from serial number HA 204 YY XX XXXX
ET 210iP from serial number HA 205 YY XX XXXX
X and Y represents digits, 0 to 9 in the serial number, where YY indicates year of production.

Brand name or trademark

ESAB

Manufacturer or his authorised representative established within the EEA

ESAB AB
Lindholmsallén 9, Box 8004, SE-402 77 Göteborg, Sweden
Phone: +46 31 50 90 00, www.esab.com

The following EN standards and regulations in force within the EEA has been used in the design:

EN IEC 60974-1:2018/A1:2019	Arc Welding Equipment - Part 1: Welding power sources
EN 60974-3:2014	Arc Welding Equipment - Part 3: Arc striking and stabilizing devices
EU reg. no. 2019/1784	Ecodesign requirements for welding equipment pursuant to Directive 2009/125/EC
EN 60974-10:2014	Arc Welding Equipment - Part 10: Electromagnetic compatibility (EMC) requirements

Additional Information:

Restrictive use, Class A equipment, intended for use in locations other than residential.
The ET 180iP and ET 210iP are part of the ESAB Renegade product family.

By signing this document, the undersigned declares as manufacturer, or the manufacturer's authorised representative established within the EEA, that the equipment in question complies with the safety and environmental requirements stated above.

Place/Date

Gothenburg
2022-06-07

Signature

Pedro Muniz
Standard Equipment Director





UK DECLARATION OF CONFORMITY

According to:

- Electric Equipment (Safety) Regulations 2016;
- Electromagnetic Compatibility Regulations 2016;
- The Restriction of the Use of Certain Hazardous Substances in Electrical and Electronic Equipment Regulations 2012 (as amended)
- The Ecodesign for Energy-Related Products and Energy Information Regulations 2021

Type of equipment

Arc welding power source

Type designation

ET 180iP from serial number HA 204 YY XX XXXX

ET 210iP from serial number HA 205 YY XX XXXX

X and Y represents digits, 0 to 9 in the serial number, where YY indicates year of production.

Brand name or trademark

ESAB

Manufacturer or his authorised representative established within United Kingdom

ESAB Group (UK) Ltd,
322 High Holborn, London, WC1V 7PB, United Kingdom
www.esab.co.uk

The following British Standards and Instruments in force within the United Kingdom has been used in the design:

- EN IEC 60974-1:2018/A1:2019	Arc welding equipment - Part 1: Welding power sources
- EN IEC 60974-3:2019	Arc welding equipment - Part 3: Arc striking and stabilizing devices
- EN 60974-10:2014	Arc welding equipment - Part 10: Electromagnetic compatibility (EMC)
- UK S.I. 2021/745	Requirements for welding equipment pursuant to the Ecodesign for Energy-Related Products and Energy Information Regulations 2021

Additional Information:

Restrictive use, Class A equipment, intended for use in locations other than residential.

ET 180iP and ET 210iP are part of ESAB Renegade product family.

By signing this document, the undersigned declares as manufacturer, or the manufacturer's authorised representative established within the UK, that the equipment in question complies with the safety and environmental requirements stated above.

Gary Kisby

Signatures

Gary Kisby
Sales & Marketing Director,
ESAB Group UK & Ireland
London, 2022-06-07

UK
CA

TABLE OF CONTENTS

1	SAFETY	5
1.1	Meaning of symbols	5
1.2	Safety precautions	5
2	INTRODUCTION	9
2.1	Equipment	9
3	TECHNICAL DATA	10
3.1	ECO design information	12
4	INSTALLATION	13
4.1	Location	13
4.2	Lifting instructions	14
4.3	Mains supply	14
5	OPERATION	16
5.1	Connections and control devices	16
5.2	TIG welding	16
5.3	MMA welding	17
5.4	Connecting welding and return cables	17
5.5	Turning the power on/off	17
5.6	Connect to cooler EC 1001 (ET 210iP only)	18
5.7	Fan control	18
5.8	Thermal protection	18
5.9	Remote control	19
5.10	Functions and symbols	19
5.11	Setting panel	21
	5.11.1 Navigation	22
5.12	TIG settings	22
	5.12.1 Hidden TIG functions	23
	5.12.2 Measured values	23
5.13	TIG functions explanation	23
	5.13.1 Foot pedal functions explanation	26
5.14	MMA settings	27
	5.14.1 Hidden MMA functions	27
	5.14.2 Measured values	23
5.15	MMA functions explanation	28
6	MAINTENANCE	29
6.1	Routine maintenance	29
6.2	Cleaning instruction	30
7	TROUBLESHOOTING	33
8	ERROR CODES	34
8.1	Error code descriptions	34
9	ORDERING SPARE PARTS	35
	WIRING DIAGRAM	36
	ORDERING NUMBERS	37
	ACCESSORIES	38

1 SAFETY

1.1 Meaning of symbols

As used throughout this manual: Means Attention! Be Alert!



DANGER!

Means immediate hazards which, if not avoided, will result in immediate, serious personal injury or loss of life.



WARNING!

Means potential hazards which could result in personal injury or loss of life.



CAUTION!

Means hazards which could result in minor personal injury.



WARNING!

Before use, read and understand the instruction manual and follow all labels, employer's safety practices and Safety Data Sheets (SDSs).



1.2 Safety precautions

Users of ESAB equipment have the ultimate responsibility for ensuring that anyone who works on or near the equipment observes all the relevant safety precautions. Safety precautions must meet the requirements that apply to this type of equipment. The following recommendations should be observed in addition to the standard regulations that apply to the workplace.

All work must be carried out by trained personnel well-acquainted with the operation of the equipment. Incorrect operation of the equipment may lead to hazardous situations which can result in injury to the operator and damage to the equipment.

1. Anyone who uses the equipment must be familiar with:
 - its operation
 - location of emergency stops
 - its function
 - relevant safety precautions
 - welding and cutting or other applicable operation of the equipment
2. The operator must ensure that:
 - no unauthorised person is stationed within the working area of the equipment when it is started up
 - no-one is unprotected when the arc is struck or work is started with the equipment
3. The workplace must:
 - be suitable for the purpose
 - be free from drafts

4. Personal safety equipment:

- Always wear recommended personal safety equipment, such as safety glasses, flame-proof clothing, safety gloves
- Do not wear loose-fitting items, such as scarves, bracelets, rings, etc., which could become trapped or cause burns

5. General precautions:

- Make sure the return cable is connected securely
- Work on high voltage equipment **may only be carried out by a qualified electrician**
- Appropriate fire extinguishing equipment must be clearly marked and close at hand
- Lubrication and maintenance must **not** be carried out on the equipment during operation

If equipped with ESAB cooler

Use ESAB approved coolant only. Non-approved coolant might damage the equipment and jeopardize product safety. In case of such damage, all warranty undertakings from ESAB cease to apply.

For ordering information, see the "ACCESSORIES" chapter in the instruction manual.



WARNING!

Arc welding and cutting can be injurious to yourself and others. Take precautions when welding and cutting.



ELECTRIC SHOCK - Can kill

- Install and ground the unit in accordance with instruction manual.
- Do not touch live electrical parts or electrodes with bare skin, wet gloves or wet clothing.
- Insulate yourself from work and ground.
- Ensure your working position is safe



ELECTRIC AND MAGNETIC FIELDS - Can be dangerous to health

- Welders having pacemakers should consult their physician before welding. EMF may interfere with some pacemakers.
- Exposure to EMF may have other health effects which are unknown.
- Welders should use the following procedures to minimize exposure to EMF:
 - Route the electrode and work cables together on the same side of your body. Secure them with tape when possible. Do not place your body between the torch and work cables. Never coil the torch or work cable around your body. Keep welding power source and cables as far away from your body as possible.
 - Connect the work cable to the workpiece as close as possible to the area being welded.



FUMES AND GASES - Can be dangerous to health

- Keep your head out of the fumes.
- Use ventilation, extraction at the arc, or both, to take fumes and gases away from your breathing zone and the general area.



ARC RAYS - Can injure eyes and burn skin

- Protect your eyes and body. Use the correct welding screen and filter lens and wear protective clothing.
- Protect bystanders with suitable screens or curtains.



NOISE - Excessive noise can damage hearing

Protect your ears. Use earmuffs or other hearing protection.



MOVING PARTS - Can cause injuries

- Keep all doors, panels and covers closed and securely in place. Have only qualified people remove covers for maintenance and troubleshooting as necessary. Reinstall panels or covers and close doors when service is finished and before starting engine.



- Stop engine before installing or connecting unit.
- Keep hands, hair, loose clothing and tools away from moving parts.



FIRE HAZARD

- Sparks (spatter) can cause fire. Make sure that there are no inflammable materials nearby.
- Do not use on closed containers.



HOT SURFACE - Parts can burn

- Do not touch parts bare handed.
- Allow cooling period before working on equipment.
- To handle hot parts, use proper tools and/or insulated welding gloves to prevent burns.

MALFUNCTION - Call for expert assistance in the event of malfunction.

PROTECT YOURSELF AND OTHERS!



CAUTION!

This product is solely intended for arc welding.



WARNING!

Do not use the power source for thawing frozen pipes.



CAUTION!

Class A equipment is not intended for use in residential locations where the electrical power is provided by the public low-voltage supply system. There may be potential difficulties in ensuring electromagnetic compatibility of class A equipment in those locations, due to conducted as well as radiated disturbances.

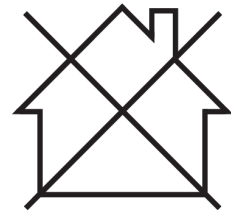

NOTE!

Dispose of electronic equipment at the recycling facility!

In observance of European Directive 2012/19/EC on Waste Electrical and Electronic Equipment and its implementation in accordance with national law, electrical and/or electronic equipment that has reached the end of its life must be disposed of at a recycling facility.

As the person responsible for the equipment, it is your responsibility to obtain information on approved collection stations.

For further information contact the nearest ESAB dealer.



ESAB has an assortment of welding accessories and personal protection equipment for purchase. For ordering information contact your local ESAB dealer or visit us on our website.

2 INTRODUCTION

Renegade ET 180iP and ET 210iP are inverter-based power sources intended for MMA (Manual Metal Arc), TIG (Tungsten Inert Gas) and HF TIG (High Frequency Tungsten Inert Gas) welding.

ESAB accessories for the product can be found in the "ACCESSORIES" chapter of this manual.

2.1 Equipment

Renegade ET 180iP and ET 210iP include:

- Power source
- Work clamp leadset
- Gas hose
- Shoulder strap
- Safety manual
- Quick setup guide

3 TECHNICAL DATA

	Renegade ET 180iP		Renegade ET 210iP	
Outlet voltage	230 V \pm 15%, 1~ 50/60 Hz	115 V \pm 15%, 1~ 50/60 Hz	230 V \pm 15%, 1~ 50/60 Hz	115 V \pm 15%, 1~ 50/60 Hz
Primary current				
I_{max}	26 A	29 A	26 A	29 A
No-load power demand when in energy-saving mode	25 W 18 W	25 W 18 W	25 W 18 W	25 W 18 W
Setting range				
MMA	15-180 A	15-110 A	15-180 A	15-110 A
TIG	10-180 A	10-140 A	10-210 A	10-140 A
Permissible load at MMA				
25 % duty cycle	180 A / 27.2 V	110 A / 24.4 V	180 A / 27.2 V	110 A / 24.4 V
60 % duty cycle	116 A / 24.6 V	71 A / 22.8 V	116 A / 24.6 V	71 A / 22.8 V
100% duty cycle	90 A / 23.6 V	55 A / 22.2 V	90 A / 23.6 V	55 A / 22.2 V
Permissible load at TIG				
25 % duty cycle	180 A / 17.2 V	140 A / 15.6 V	210 A / 18.4 V	140 A / 15.6 V
60 % duty cycle	116 A / 14.6 V	90 A / 13.6 V	135 A / 15.4 V	90 A / 13.6 V
100% duty cycle	90 A / 13.6 V	70 A / 12.8 V	105 A / 14.2 V	70 A / 12.8 V
Apparent power I₂ at maximum current	6.1 kVA	3.33 kVA	6.1 kVA	3.33 kVA
Active power I₂ at maximum current	6 kW	3.3 kW	6 kW	3.3 kW
Power factor at maximum current				
MMA	0.99			
TIG	0.99			
Efficiency at maximum current				
MMA	84%	84%	84%	84%
TIG	81%	81%	81%	81%
Open-circuit voltage U₀ max				
VRD 35 V deactivated	78 V			
VRD 35 V activated	<30 V			
Operating temperature	-10 to +40°C (+14 to 104°F)			
Transportation temperature	-20 to +55°C (-4 to +161°F)			
Constant sound pressure when idling	<70 db			
Dimensions l × w × h	460 × 200 × 320 mm (18.1×7.9×12.6 in.)			
Weight	11 kg (24.3 lbs)			
Insulation class	F			

	Renegade ET 180iP	Renegade ET 210iP
Enclosure class	IP 23	
Application class	S	

Duty cycle

The duty cycle refers to the time as a percentage of a ten-minute period that you can weld or cut at a certain load without overloading. The duty cycle is valid for 40 °C / 104 °F, or below.

Enclosure class

The **IP** code indicates the enclosure class, i.e. the degree of protection against penetration by solid objects or water.

Equipment marked **IP23** is intended for indoor and outdoor use.

Application class

The symbol **S** indicates that the power source is designed for use in areas with increased electrical hazard.

3.1 ECO design information

The equipment has been designed in order to be compliant with the Directive 2009/125/EC and the Regulation 2019/1784/EU.

Efficiency and idle power consumption:

Name	Idle power	Efficiency when max power consumption
Renegade ET 180iP	<50 W	83%
Renegade ET 210iP	<50 W	83%

The value of efficiency and consumption in idle state have been measured by method and conditions defined in the product standard EN 60974-1:2012.

Manufacturer's name, product name, serial number and date of production can be read from rating plate.

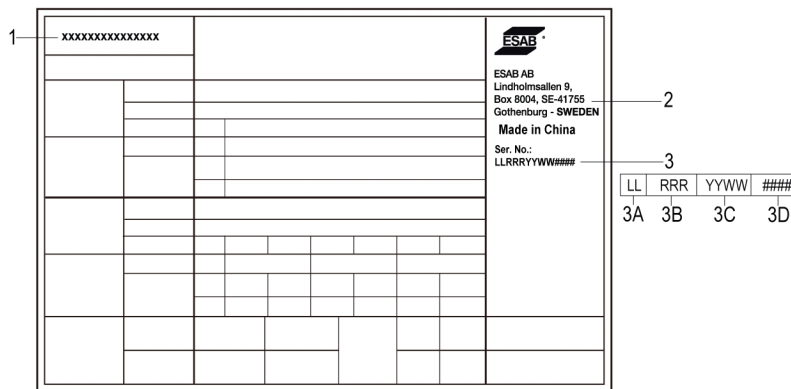

- 1. Product name
- 2. Manufacturer's name and address
- 3. Serial number
 - 3A. Manufacturing location code
 - 3B. Revision level (last digit of year and week number)
 - 3C. Year & week produced (last two digits of year and week number)
 - 3D. Sequential number system (each week starts with 0001)

4 INSTALLATION

The installation must be carried out by a professional.



CAUTION!

This product is intended for industrial use. In a domestic environment this product may cause radio interference. It is the user's responsibility to take adequate precautions.

4.1 Location

Position the power source so that cooling air inlets and outlets are not obstructed.

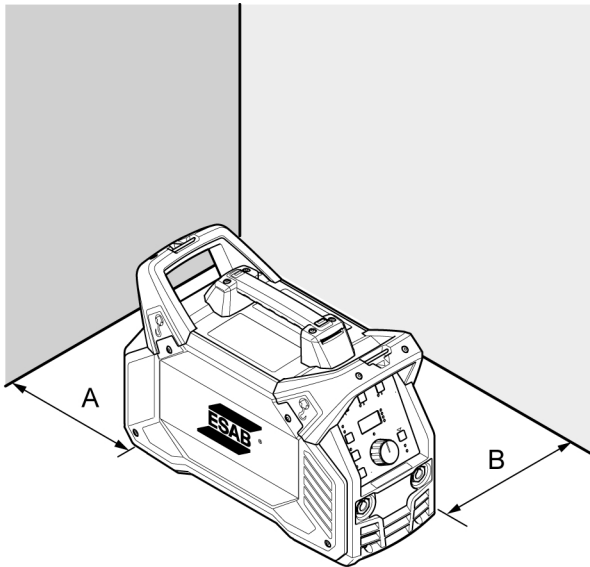

A. Minimum 200 mm (8 in.)

B. Minimum 200 mm (8 in.)



WARNING!

Secure the equipment - particularly if the ground is uneven or sloping.

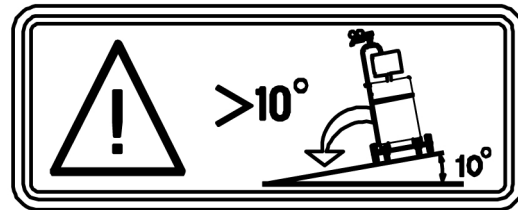

4.2 Lifting instructions

These units are equipped with a handle for carrying purposes.



WARNING!

Electric shock can kill. Do not touch live electrical parts. Disconnect input power conductors from de-energized supply line before moving the welding power source.



WARNING!

Falling equipment can cause serious personal injury and equipment damage.

Lift the unit with handle on top of case.

Max. 30°

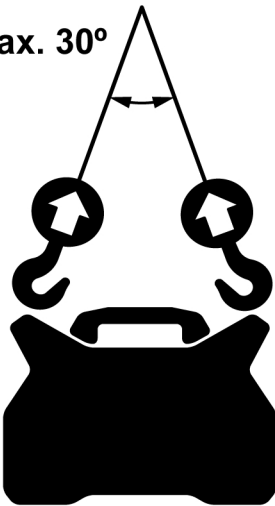

4.3 Mains supply



NOTE!

Mains supply requirements

This equipment complies with IEC 61000-3-12 provided that the short-circuit power is greater than or equal to S_{scmin} at the interface point between the user's supply and the public system. It is the responsibility of the installer or user of the equipment to ensure, by consultation with the distribution network operator if necessary, that the equipment is connected only to a supply with a short-circuit power greater than or equal to S_{scmin} .

1. Rating plate with supply connection data.

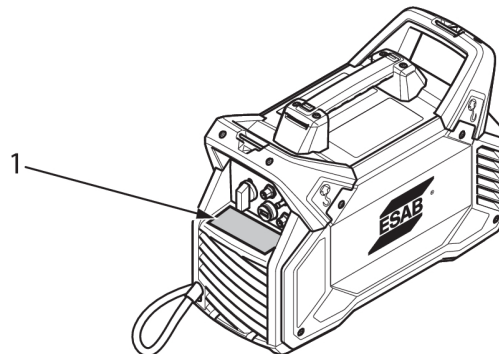

Recommended fuse sizes and minimum cable area for the Renegade ET 180iP and ET 210iP				
	Renegade ET 180iP		Renegade ET 210iP	
Supply voltage	230 V AC	115 V AC	230 V AC	115 V AC
Mains cable area	2.5 mm ²	2.5 mm ²	2.5 mm ²	2.5 mm ²
Maximal current rating I_{max} MMA/Stick (SMAW)	26 A	29 A	26 A	29 A
I_{1eff} MMA/Stick (SMAW)	13 A	14.5 A	13 A	14.5 A
Fuse anti-surge type D MCB	20 A	20 A	20 A	20 A
Maximum recommended extension cord length	100 m (328 ft)	100 m (328 ft)	100 m (328 ft)	100 m (328 ft)
Minimum recommended extension cord size	2.5 mm ²	2.5 mm ²	2.5 mm ²	2.5 mm ²

Supply from power generators

The power source can be supplied from different types of generators. However, some generators may not provide sufficient power for the welding power source to operate correctly. Generators with Automatic Voltage Regulation (AVR) or with equivalent or better type of regulation, with rated power of 7 kW are recommended.



WARNING!

If used under 115 VAC input supply, the supply plug rating must be higher than 20 A.

5 OPERATION

General safety regulations for handling the equipment can be found in the "SAFETY" chapter of this manual. Read it through before you start using the equipment!



NOTE!

When moving the equipment use intended handle. Never pull the cables.



WARNING!

Electric shock! Do not touch the workpiece or the welding head during operation!

5.1 Connections and control devices

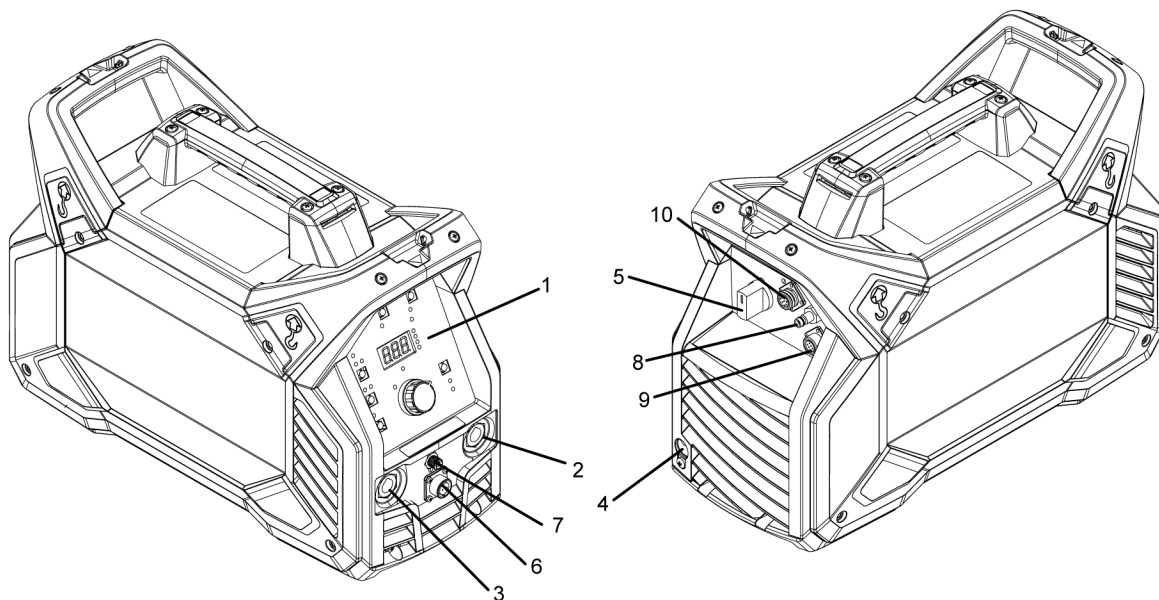

- | | |
|-----------------------------------|--|
| 1. Setting panel | 6. TIG switch socket |
| 2. Positive welding terminal | 7. Gas supply output |
| 3. Negative welding terminal | 8. Gas supply input |
| 4. Power cable | 9. Water cooler connector (ET 210 iP only) |
| 5. Mains power supply switch, I/O | 10. Remote socket |

5.2 TIG welding



TIG welding melts the metal of the workpiece, using an arc initiated from a non-consuming tungsten electrode. The weld pool and electrode are protected by a shielding gas that usually consists of an inert gas.

For TIG welding, the welding power source shall be supplemented with:

- a TIG torch
- a gas hose connected to the gas supply input (using a hose clamp)
- an argon gas cylinder
- an argon gas regulator
- a tungsten electrode
- a return cable (with clamp)

5.3 MMA welding



MMA welding may also be referred to as welding with covered electrodes. The arc melts the electrode as well as a local part of the workpiece. The coverage, when melting, forms a protective slag and creates a shielding gas to protect the weld pool from atmospheric contamination.

For MMA welding the power source shall be supplemented with:

- welding cable with electrode holder
- return cable with clamp

5.4 Connecting welding and return cables

The power source has two outputs, a positive welding terminal (+) and a negative welding terminal (-), for connecting welding and return cables. The output to which the welding cable is connected depends on the welding method or type of electrode used.

Connect the return cable to the other output on the power source. Secure the return cable's contact clamp to the workpiece, and make sure that there is a good contact between the workpiece and the output for the return cable on the power source.

- For TIG welding, the negative welding terminal (-) is used for the welding torch and the positive welding terminal (+) is used for the return cable.
- For MMA welding, the welding cable can be connected to the positive welding terminal (+) or negative welding terminal (-), depending on the type of electrode used. The connection polarity is stated on the electrode packaging.

5.5 Turning the power on/off

Turn on the power by turning the switch to the "ON" (I) position.

Turn the unit off by turning the switch to the "O" position.

Whether the power supply is interrupted or the power source is switched off in the normal manner, weld programs are stored so that they are available the next time the unit is started.



CAUTION!

Do not turn off the power source during welding (with load).

5.6 Connect to cooler EC 1001 (ET 210iP only)

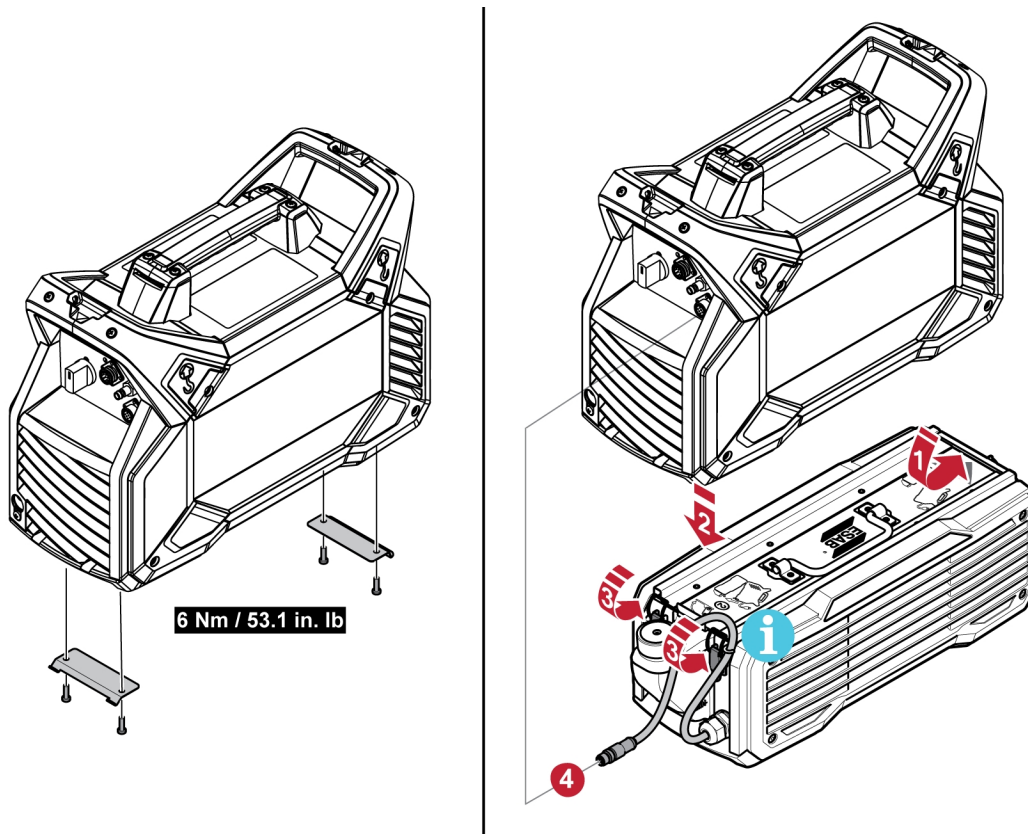

i NOTE!
Take care so that the interface cable does not get squeezed between the power source and the cooling unit!

i NOTE!
Power supply of the cooling unit is done from the welding power source via the connection cable (for more information, refer to the cooling unit instruction manual).

5.7 Fan control

The ET 180iP and ET 210iP are fitted with a fan as an additional feature. When cooling fan is not in use, the fan will automatically turn off.

This has two advantages:

1. To minimize power consumption,
2. To minimize the amount of pollutants absorbed into the power source, such as dust.

i NOTE!
When cooling requires, the fan will operate otherwise it will automatically turn off.

5.8 Thermal protection



The power source includes thermal protection against overheating. When overheating occurs the welding is stopped and overheating indicator on the panel will be lit and an error message ERR 206 shows in the display. The protection is automatically reset when the temperature has been sufficiently reduced.

5.9 Remote control



Connect the remote control on the rear side of the power source and activate the remote control by pressing the remote control button on the panel (remote control indicator being lit when activated). When the remote control is activated the control panel is locked for interaction but displays welding data.

Should a remote device be connected the maximum output current of the power source will be determined by the front panel control knob, irrespective of the remote control device setting.

5.10 Functions and symbols



MMA welding

MMA welding may also be referred to as welding with coated electrodes. Striking the arc melts the electrode, and its coating forms protective slag.

For MMA welding the power source shall be supplemented with:

- welding cable with electrode holder
- return cable with clamp

Arc force (Hidden function)

The arc force function determines how the current changes in response to variations in arc length during welding. Use a low value of arc force to get a calm arc with little spatter and use a high value to get a hot and digging arc.

Arc force only applies to MMA welding.

Hot start (Hidden function)

The hot start function temporarily increases the current in the beginning of the weld. Use this function to reduce risk of insufficient fusion and electrode sticking and scratching.

Hot start only applies to MMA welding.



TIG welding

TIG welding melts the metal of the workpiece, an arc initiated from a non-consuming tungsten electrode. The weld pool and electrode are protected by shielding gas.

For TIG welding, the welding power source shall be supplemented with:

- a TIG torch
- an argon gas cylinder
- an argon gas regulator
- tungsten electrode

This power source performs **LIFT TIG start**.

The tungsten electrode is placed against the workpiece and press the torch trigger. When lifted away from workpiece the arc is struck at a limited current level.

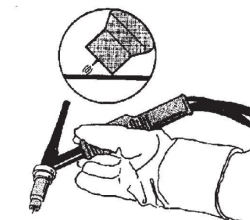
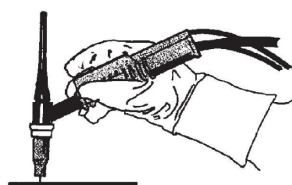



HF start

The HF (High Frequency) start function strikes the arc by means of a spark from the tungsten electrode to the workpiece as the electrode is brought closer to the workpiece and the trigger on the TIG torch is pressed.

Voltage Reduction Device (VRD)

VRD

The VRD function ensures that the open-circuit voltage does not exceed 35 V when welding is not being carried out. This is indicated by a lit VRD indicator on the panel. Contact an authorised ESAB service technician to activate this function.

5.11 Setting panel

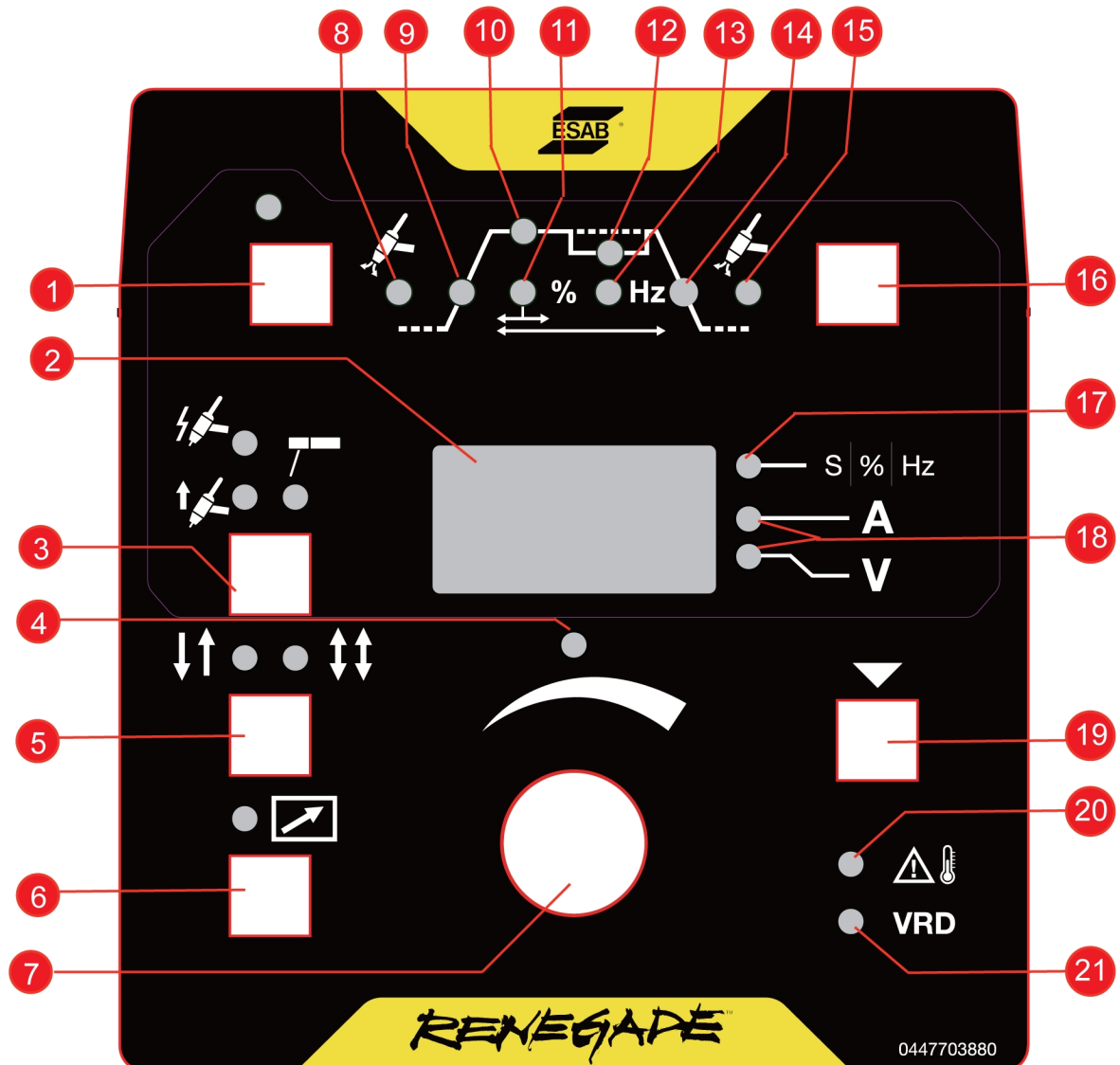

1. Button to change between direct current and pulse current.
2. Display, shows set or measured value.
3. Button to select welding method: TIG HF, LiftArc™ or MMA.
4. Set indicator.
5. Button to select 2-stroke or 4-stroke (TIG only).
6. Button to activate and deactivate remote control unit.
7. Knob for setting data.
8. Gas pre flow indicator.
9. Slope up indicator.
10. Direct current or pulse current indicator.
11. Pulse balance.
12. Background current indicator.
13. Pulse frequency indicator.
14. Slope down indicator.
15. Gas post flow indicator.
16. Button to change between the parameters in the graph.
17. Indicates which is shown in the display: s (seconds for gas pre flow, gas post flow, slope up and slope down), % (pulse balance), Hz (pulse frequency).
18. Current set and measure value / Voltage measure value.
19. Parameter selection button, selection indicated by (18). Also used for access to hidden functions.
20. Overheating indicator.
21. VRD function (reduced open-circuit voltage) indicator.

5.11.1 Navigation

Parameter selection

By pressing the button (19) different values can be shown and changed. Use the knob (7) to change the values. The sequence is:

1. Set current value.
2. Measured current value.
3. Measured voltage value.

Set parameter









The set indicator (4) will be lit when a displayed value can be changed. It cannot be changed from the panel when a remote control is activated. Trying to change a value while in measured value mode will result in automatically move to set current value mode.

The set indicator (4) is off when measured values are shown.

Weld parameters

The weld parameters are stored for pulse and no pulse respectively. The values are changed when changing between pulse and no pulse.

5.12 TIG settings

Symbol	Function	Setting range	Setting steps	Default value	ET 180iP & ET 210iP
	TIG HF*	ON/OFF		ON	x
	LiftArc*	ON/OFF		OFF	x
A	Current	1ph: 10-210 A	1	120 A	x
	Slope up time	0.0-25.0 s	0.1	1.5 s	x
	Slope down time	0.0-25.0 s	0.1	3.0 s	x
	Gas pre flow time	0.0-25.0 s	0.1	1.0 s	x
	Gas post flow time	0.0-25.0 s	0.1	7.0 s	x
	2-stroke*	ON/OFF		ON	x
	4-stroke*	ON/OFF		OFF	x
	Remote control unit*	ON/OFF		OFF	x
	Pulse*	ON/OFF		OFF	x
	Pulse current	1ph: 10-210 A		120 A	x

Symbol	Function	Setting range	Setting steps	Default value	ET 180iP & ET 210iP
	Background current	1ph: 10-210 A		80 A	x
	Pulse balance	10-90%	5	50%	x
	Pulse frequency	0.01-999 Hz	0.01-0.99: 0.01 1.0-9.9: 0.1 10-100: 1 100-300: 10 300-999: 100	100 Hz	x
	Remote min current	0-99%	1	0%	H

* Parameter cannot be changed during welding.

5.12.1 Hidden TIG functions

There are hidden functions in the control panel. To access the functions, press parameter selection button (19) for 3 seconds (refer to section SETTING PANEL for button placement). The display shows a letter and a value. Select function by pressing the same button. The knob is used to change the value of the selected function. To exit hidden functions, press the button for 3 seconds again.

Letter	Function	Settings
E	Dual current mode	0=OFF, 1=ON
e	Dual current mode setting value	10-90%
I	Remote min current	0-99%

5.12.2 Measured values

A

Measured current

Measured value in the display for welding current A is arithmetic average value.

V

Measured voltage

Measured value in the display for arc voltage V is arithmetic average value.

5.13 TIG functions explanation



HF start

The HF start function initiates the arc by using a high frequency voltage pilot arc. This will reduce the risk of tungsten contamination in the starts. The high frequency voltage might disturb other electrical equipment in the surrounding area.

**LiftArc™**

The LiftArc™ function initiates the arc when the tungsten electrode is brought into contact with the workpiece, the trigger switch is pressed, and the tungsten electrode is lifted away from the workpiece. In order to minimize the risk of tungsten contaminations the start current is very low and will slope up to the set current (controlled by the slope up function).

**2-stroke**

In 2-stroke mode, press the TIG torch trigger switch (1) to start the shielding gas flow and initiate the arc. The current slopes up to the set current value. Release the trigger switch (2) to start to slope down the current and terminate the arc. The shielding gas will continue to flow in order to protect the weld and the tungsten electrode.

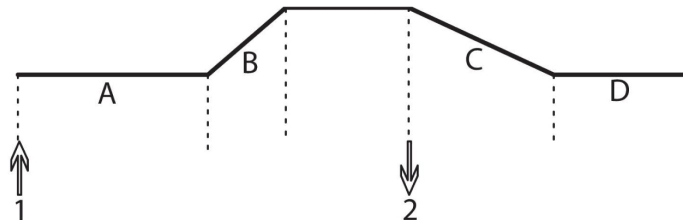

A = Gas pre flow

B = Slope up

C = Slope down

D = Gas post flow

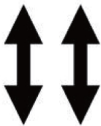
**4-stroke**

In 4-stroke mode, press the TIG torch trigger switch (1) to start shielding gas flow and initiate the arc at a pilot level. Release the trigger switch (2) to slope up the current to the set current value. To stop the welding, press the trigger switch again (3). The current will slope down to the pilot level again. Release the trigger switch (4) to terminate the arc. The shielding gas will continue to flow in order to protect the weld and the tungsten electrode.

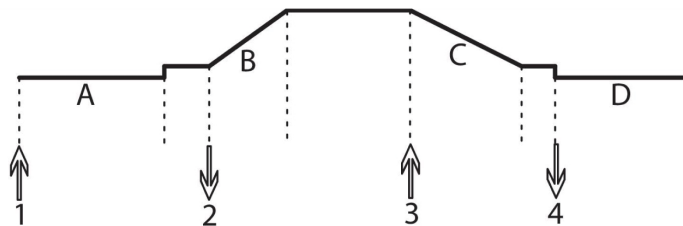

A = Gas pre flow

B = Slope up

C = Slope down

D = Gas post flow

**Gas pre flow**

The gas pre flow function controls the time during which shielding gas flows before the arc is initiated.

**Gas post flow**

The gas post flow function controls the time during which shielding gas flows after the arc is terminated.

Slope up

The slope up function is used to control the time of the current increase in the weld initiation process to avoid any possible damage to the tungsten electrode.

Slope down

The slope down function is used to control the time of the current decrease in the weld termination process to avoid any pipes and/or cracks.

Pulse settings

In order to set a pulsed current, four parameters are required: pulse current, background current, pulse balance and pulse frequency.

Pulse current

The higher of the two current values when using a pulsed current.

Pulse background current

The lower of the two current values when using a pulsed current.

Pulse balance

Pulse balance is the ratio between pulse current and background current in a pulse cycle. In order to control the energy of the arc and the size of the weld pool, pulse balance is adjustable by setting the percentage of the pulse current in a pulse cycle.

For example: If the pulse balance is set to 50%, the time of the pulse current and the background current will be distributed equally in the pulse cycle. If the pulse balance is set to 90%, the time of the pulse current will be 90% of the pulse cycle and the background current will only be 10%.

Pulse frequency

The amount of pulse cycles in a time period. The higher the frequency, the more pulse cycles per time period. When the pulse frequency is set low, the weld pool will have time to partially solidify between each pulse. If the frequency is set high, a more focused arc can be obtained.

Remote min current

This is used to set the minimum current for the foot pedal. Is set in % of the set current in the range from 0–99% in steps of 1%.

For example: If the current is set to 100 A and the remote min current function is set to 20, the remote min current will be 20 A. If the current is set to 80 A and the remote min current function is set to 50, the remote min current will be 40 A.

5.13.1 Foot pedal functions explanation

Foot pedal with 2-stroke using TIG torch trigger

In 2-stroke mode, with the foot pedal activated, press the TIG torch trigger switch (1) to start the shielding gas flow and initiate the arc. The current slopes up to the set remote min current. Use the foot pedal to adjust the current between the remote min current and the set current value. Release the TIG torch trigger switch (2) to start to slope down the current and terminate the arc. The shielding gas will continue to flow in order to protect the weld and the tungsten electrode.

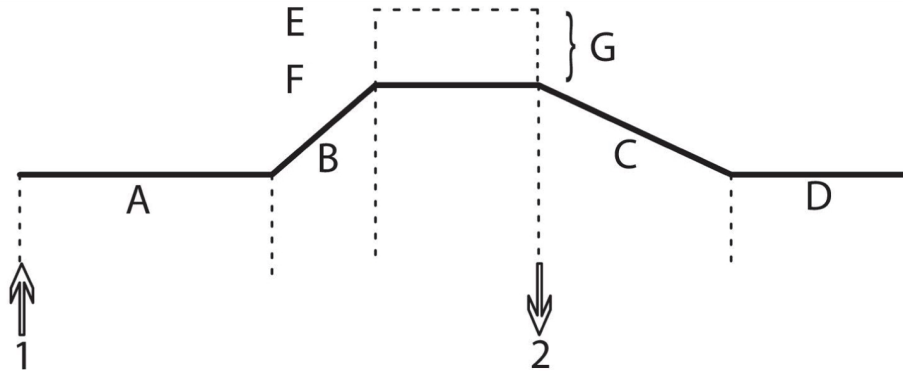

A = Gas pre flow

B = Slope up

C = Slope down

D = Gas post flow

E = Set current

F = Remote min current

G = Current range adjustable by the foot pedal

Foot pedal with 4-stroke using TIG torch trigger

In 4-stroke mode, with the foot pedal activated, press the TIG torch trigger switch (1) to start the shielding gas flow and initiate the arc at a pilot level. Release the trigger switch (2) to slope up the current to the remote min current. Use the foot pedal to adjust the current between the remote min current and the set current value. To stop the welding, press the trigger switch again (3). The current will slope down to the pilot level again. Release the trigger switch (4) to terminate the arc. The shielding gas will continue to flow in order to protect the weld and the tungsten electrode.

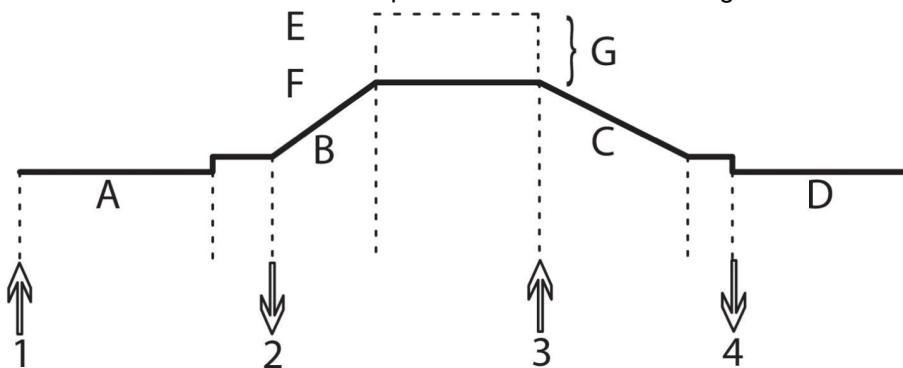

A = Gas pre flow

B = Slope up

C = Slope down

D = Gas post flow

E = Set current

F = Remote min current

G = Current range adjustable by the foot pedal

Foot pedal

Press down the foot pedal (1) to start the shielding gas flow and initiate the arc. The current slopes up to the set remote min current. Use the foot pedal to adjust the current between the remote min current and the set current value. Release the foot pedal to start to slope down the current and to terminate the arc. The shielding gas will continue to flow in order to protect the weld and the tungsten electrode.

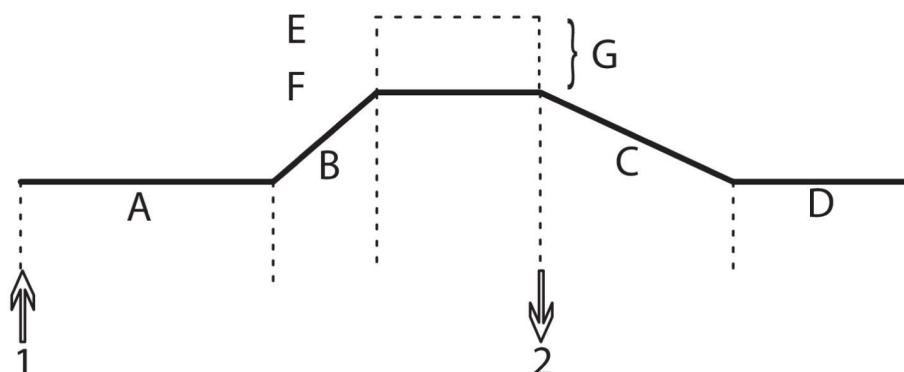

A = Gas pre flow

B = Slope up

C = Slope down

D = Gas post flow

E = Set current

F = Remote min current

G = Current range adjustable by the foot pedal

5.14 MMA settings

Symbol	Function	Setting range	Setting steps	Default value	ET 180iP & ET 210iP
	MMA*	ON/OFF		ON	x
A	Current	1ph: 15-180 A	1	100 A	
	Arc force	0-99%	1	50	H
	Hot start	0-99%	1	20%	H
	Remote control unit*	ON/OFF		OFF	x

* Parameter cannot be changed during welding.

5.14.1 Hidden MMA functions

There are hidden functions in the control panel. To access the functions, press parameter selection button for 3 seconds (refer to section SETTING PANEL for button placement). The display shows a letter and a value. Select function by pressing the same button. The knob is used to change the value of the selected function. To exit hidden functions, press the button for 3 seconds again.

Letter	Function	Settings
C	Arc force	0-99%
H	Hot start	0-99%
I	Remote min current	0-99%

5.14.2 Measured values

A

Measured current

Measured value in the display for welding current A is arithmetic average value.

V

Measured voltage

Measured value in the display for arc voltage V is arithmetic average value.

5.15 MMA functions explanation

Arc force

The arc force function determines how the current changes in response to variations in arc length during welding. Use a low value of arc force to get a calm arc with little spatter and use a high value to get a hot and digging arc.

Arc force only applies to MMA welding.

Hot start

The hot start function temporarily increases the current in the beginning of the weld, thus reducing the risk of lack of fusion in the starting point.

Hot start only applies to MMA welding.

6 MAINTENANCE

**WARNING!**

The mains supply must be disconnected during cleaning and maintenance.

**CAUTION!**

Only persons with the appropriate electrical knowledge (authorised personnel) may remove the safety plates.

**CAUTION!**

The product is covered by manufacturer's warranty. Any attempt to carry out repair work by non-authorised service centers or personnel will invalidate the warranty.

**NOTE!**

Regular maintenance is important for safe and reliable operation.

**NOTE!**





Perform maintenance more often during severe dusty conditions.

Before each use - make sure that:

- Product and cables are not damaged,
- The torch is clean and not damaged.

6.1 Routine maintenance

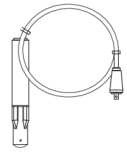
Maintenance schedule during normal conditions. Check equipment prior to every use.

Interval	Area to maintain		
Every 3 months	 Clean or replace unreadable labels.	 Clean weld terminals.	 Check or replace weld cables.
Every 6 months	 Clean inside equipment. Use dry compressed air with 4 bar pressure.		

6.2 Cleaning instruction

To maintain the performance and increase the lifetime of the power source it is mandatory to clean it regularly. How often depends on:

- the welding process
- the arc time
- the working environment



CAUTION!

Make sure that the cleaning procedure is done in a suitable prepared workspace.



CAUTION!

During cleaning, always wear recommended personal safety equipment, such as ear plugs, safety glasses, masks, gloves and safety shoes.



CAUTION!

The cleaning procedure should be carried out by authorised service technician.

1. Disconnect the power source from the mains supply.



WARNING!

Wait at least 30 seconds for the capacitors to discharge before continuing.

2. Remove the four screws holding the right side panel (**R**) and remove the panel.

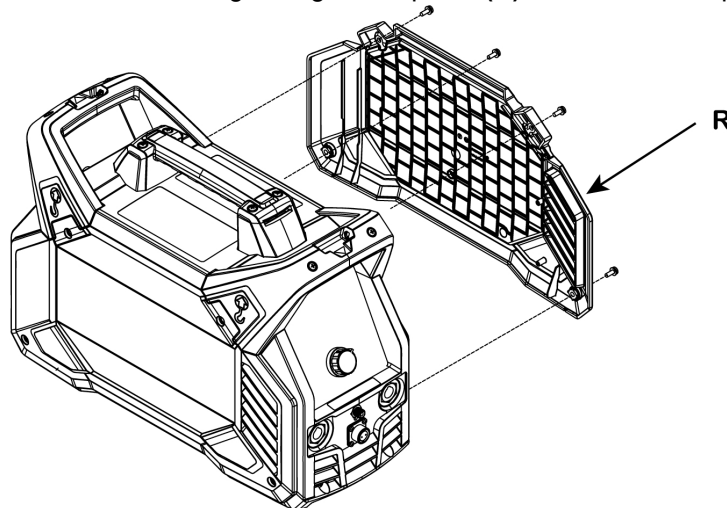

3. Clean the right side of the power source, using dry compressed air with reduced pressure.



NOTE!

Since the power source contains one "dirty side" (the right side) and one "clean side" (the left side), it is important that you do not remove **the left** side panel before cleaning the right side of the power source.

4. Remove the four screws holding the left side panel (**L**) and remove the panel.

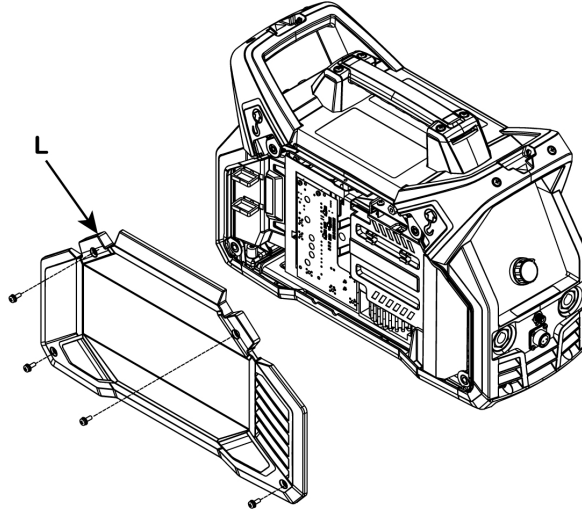

5. Clean the left side of the power source, using dry compressed air with reduced pressure.
6. Make sure that there is no dust left on any part of the power source.

7. Reassemble the power source after cleaning and perform testing according to IEC 60974-4. Follow the procedure in section "After repair, inspection and test" in the Service manual.



NOTE!

When reattaching the right side panel, make sure the IP shield on the inside of the panel is in the correct position. The IP shield should be angled approximately 90° into the power source, so that it is positioned between the welding outlet connector and the transformer outlets.

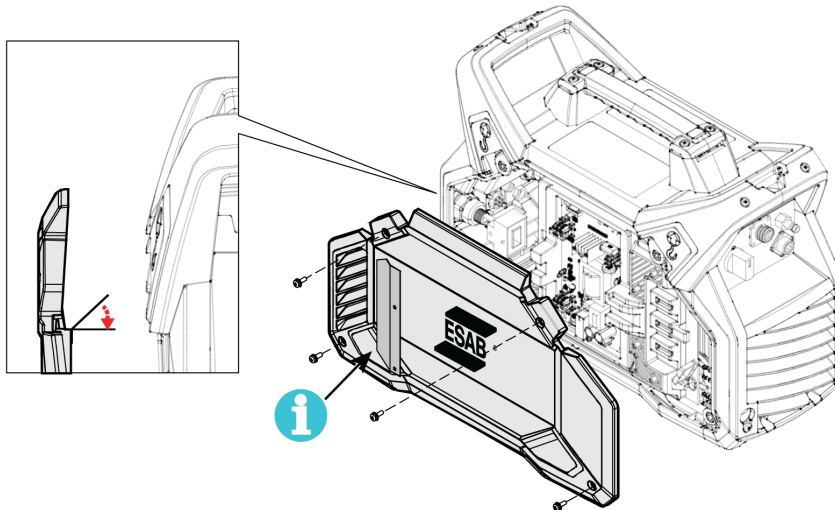

8. Tighten the screws on the side panels with $3 \text{ Nm} \pm 0.3 \text{ Nm}$ (26.6 in lb. ± 2.6).

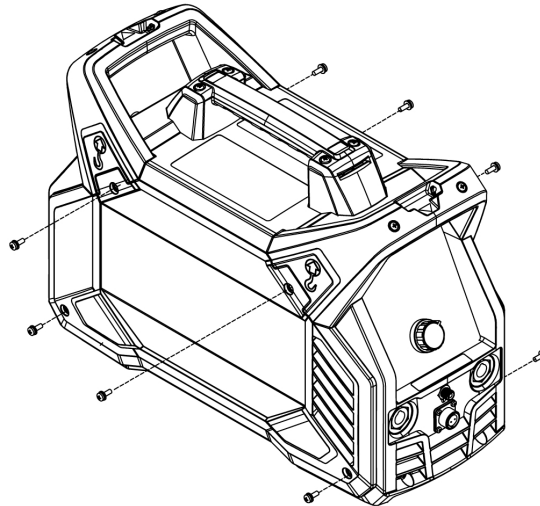

7 TROUBLESHOOTING

Perform these checks and inspections before sending for an authorised service technician.

- Check that the mains voltage is disconnected before starting any type of repair action.

Type of fault	Corrective action
MMA welding problems	Check that the welding process is set to MMA.
	Check that the welding and return cables are correctly connected to the power source.
	Make sure that the return clamp has good contact with the workpiece.
	Check that the correct electrodes and polarity are being used. For polarity, check electrode packaging.
	Check that the correct Welding current (A) is set.
	Adjust Arc Force and Hot start.
TIG welding problems	Check the welding process is set for Lift TIG as necessary.
	Check that the TIG torch and return cables are correctly connected to the power source.
	Make sure that the return clamp has good contact with the workpiece.
	Make sure that the TIG torch lead is connected to the negative welding terminal.
	Make sure that the correct shielding gas, gas flow, welding current, filler rod placement, electrode diameter and welding mode on power source is used.
No arc	Check that the electrical power supply switch is turned on.
	Check that the display is on to verify that the power source has power.
	Check that the setting panel is displaying correct values.
	Check that welding and return cables are correctly connected.
	Check the electrical power supply fuses.
Welding current is interrupted during welding	Check whether the Over Temperature LED (Thermal Protection) on the setting panel is on.
	Continue with fault type "No Arc".
The thermal protection trips frequently	Make sure the recommended duty cycle for the weld current has not been exceeded.
	See section "Duty cycle" in the TECHNICAL DATA chapter.
	Make sure the air inlets or outlets are not clogged.
	Clean inside machine according to routine maintenance.

8 ERROR CODES

The error code is used to indicate that a fault has occurred in the equipment. Errors are indicated by the text "Err" followed by the error code number shown in the display.

If several errors have been detected only the code for the last occurring error is displayed.

8.1 Error code descriptions

Error codes that the user can handle are listed below. If any other error code appears, contact an authorised ESAB service technician.

Error code	Description
Err206	<p><i>Temperature fault</i></p> <p>The temperature of the power source is too high. A LED indicating temperature fault is also lit on the panel. A temperature fault is indicated by the overheating indicator on the control panel.</p> <p>Action: The error code will automatically disappear and the LED indicating temperature fault will be turned off when the power source has cooled down and is ready for use again. If the error persists, contact a service technician.</p>
Err406	<p><i>Coolant fault</i></p> <p>The temperature of the coolant fluid is too high.</p> <p>Action: Make sure that there is sufficient coolant fluid in the cooler. The error code will automatically disappear when the coolant has cooled down and is ready for use again. If the error persists, contact a service technician.</p>
Err429	<p><i>Water cooling disabled</i></p> <p>The hose from the torch is not connected to the cooling unit.</p> <p>Action: If a water cooled torch is used make sure it is connected to the cooling unit. If a water cooled torch is not used, press a button on the control panel to cancel the error. If the error persists, contact a service technician.</p>

9 ORDERING SPARE PARTS



CAUTION!

Repair and electrical work should be performed by an authorised ESAB service technician.
Use only ESAB original spare and wear parts.

Renegade ET 180iP and ET 210iP are designed and tested in accordance with the international and European standards **EN60974-1** and **EN60974-10**. On completion of service or repair work, it is the responsibility of the person(s) performing the work to ensure that the product still complies with the requirements of the above standards.

Spare parts and wear parts can be ordered through your nearest ESAB dealer, see [esab.com](https://www.esab.com). When ordering, please state product type, serial number, designation and spare part number in accordance with the spare parts list. This facilitates dispatch and ensures correct delivery.

APPENDIX

WIRING DIAGRAM

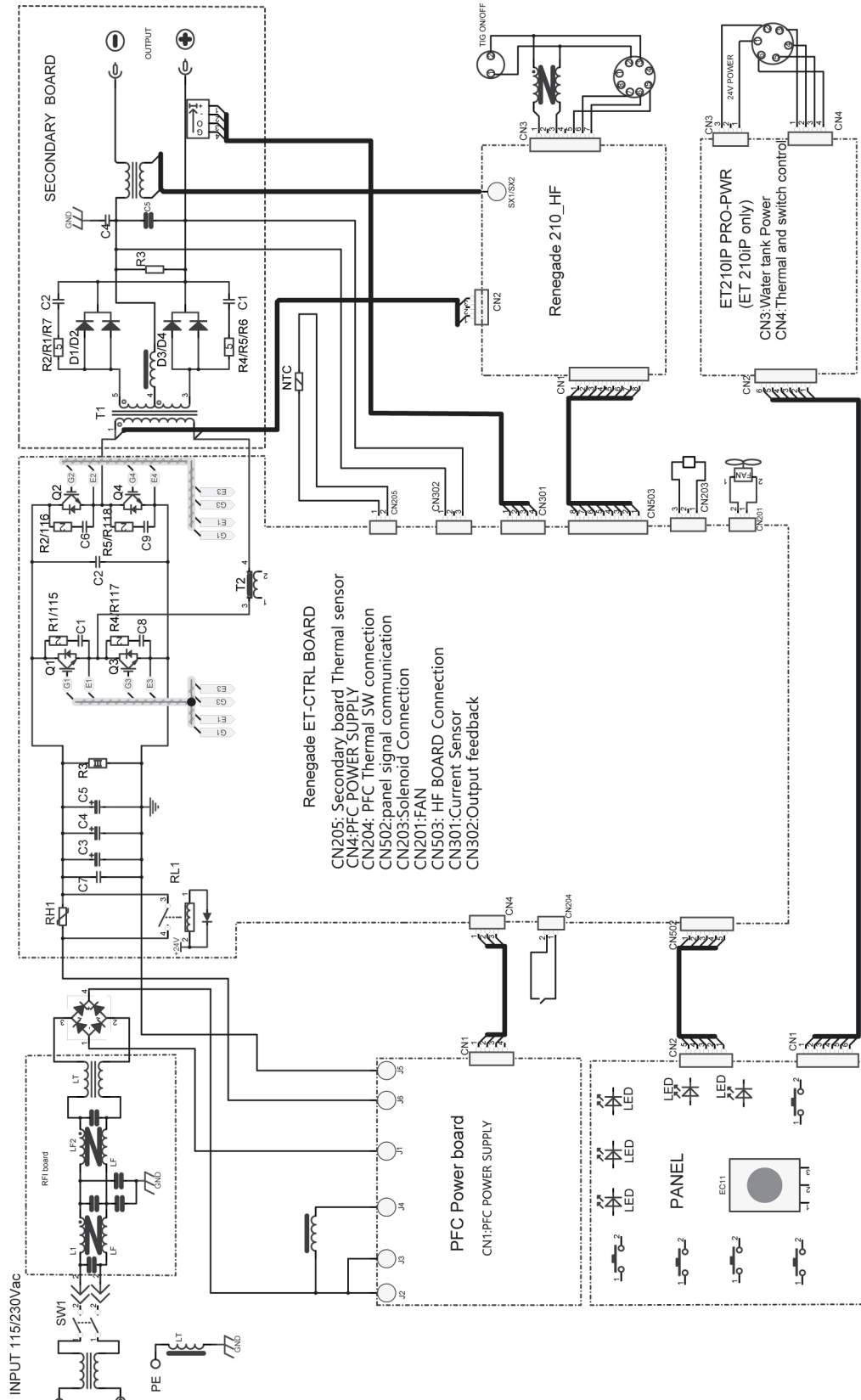

ORDERING NUMBERS

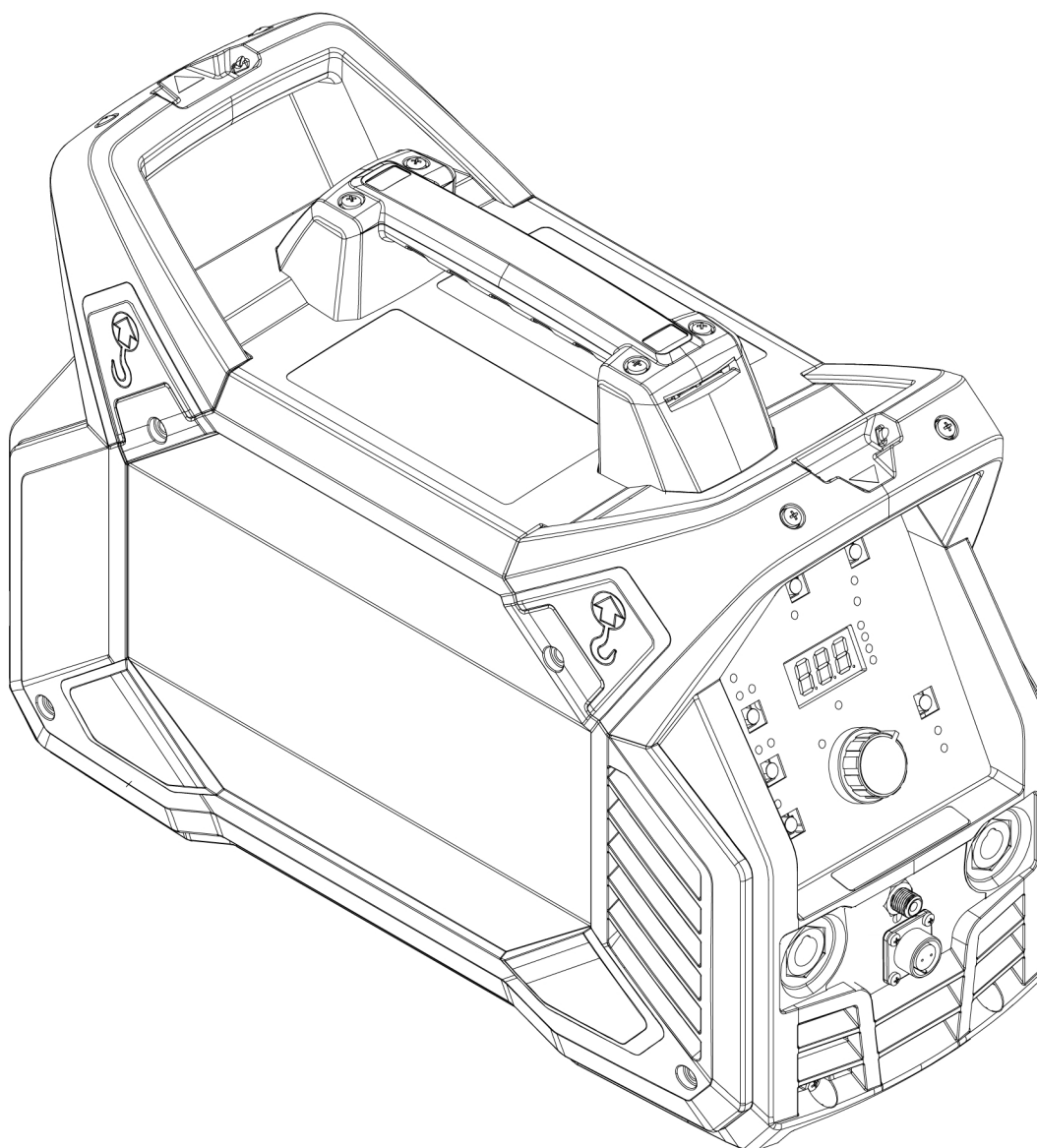

Ordering number	Denomination	Type
0447 700 910	Renegade ET 180iP and SR-B 26 TIG Torch	Renegade ET 180iP
0447 700 911	Renegade ET 210iP and SR-B 26 TIG Torch	Renegade ET 210iP
0447 700 912	Renegade ET 210iP W and SR-B 21 Water Cooled TIG Torch	Renegade ET 210iP
0463 862 *	Instruction Manual	
0463 881 *	Spare parts list	
0463 880 *	Service manual	



The three last digits in the document number of the manual show the version of the manual. Therefore they are replaced with * here. Make sure to use a manual with a serial number or software version that corresponds with the product, see the front page of the manual.

Technical documentation is available on the Internet at: www.esab.com

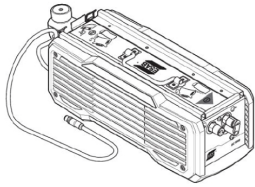
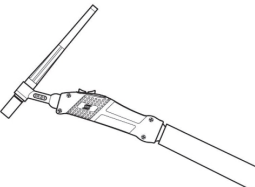
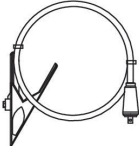
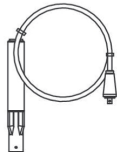
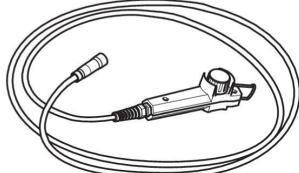
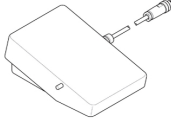
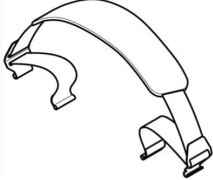
ACCESSORIES

0445 045 881	Water Cooler EC 1001 (ET 210iP)	
0700 025 518	TIG Torch, SR-B 26, 4 m	
0700 025 519	TIG Torch, SR-B 26, 8 m	
0700 025 544	Water cooled SR-B 21 Torch, OKC 50, 4 m (ET 210iP)	
0700 025 545	Water cooled SR-B 21 Torch, OKC 50, 8 m (ET 210iP)	
Return cable kits		
0700 006 901	Return cable kit, OKC 50, 3 m	
0700 006 885	Return cable kit, OKC 50, 5 m	
0700 006 900	Electrode holder Handy, 200 A with 25 mm ² , 3 m, OKC 50	
0700 500 084	Remote control, MMA 4	
W4014450	Foot pedal with 4.5 m (15 ft) cable, 8 PIN	
0445 197 880	Shoulder strap	

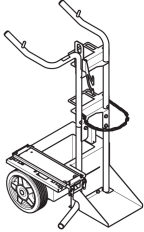
APPENDIX

0460 330 881	Trolley	 A line drawing of a trolley, which is a metal frame with a single large wheel at the front and a smaller wheel at the back. It has a handle on top and a platform at the bottom.
0465 720 002	ESAB coolant	 A line drawing of a 10-liter coolant container. It is a rectangular plastic jug with a handle on top and a cap. The text "10 L" is printed on the front.



A WORLD OF PRODUCTS AND SOLUTIONS.



For contact information visit <http://esab.com>

ESAB AB, Lindholmsallén 9, Box 8004, 402 77 Gothenburg, Sweden, Phone +46 (0) 31 50 90 00

manuals.esab.com



**CEUK
CA**

