



**LC-30(COS1)**

**WATER COOLER**

**Thank you for purchasing the water cooler!** This operating manual contains important information on the use and maintenance of this product, as well as safe handling of the product. Please refer to technical parameters of the equipment in Technical Parameter section in this manual, and read the manual carefully before using the equipment for the first time. For your own safety and that of your working environment, please pay particular attention to the safety instructions in the manual and operate the equipment according to the instructions. For more information on JASIC products, please contact JASIC Technology, consult an authorized JASIC dealer or visit JASIC website at [www.jasictech.com](http://www.jasictech.com).

## Disclaimer

**Shenzhen JASIC Technology Co., Ltd.** solemnly promises that this product is manufactured according to relevant domestic and international standards, and that this product conforms to EN60974-1 International Safety Standard. Patents protect the relevant design scheme and manufacturing technology adopted in this product.

1. Whilst every effort has been made to ensure that the information contained within this manual is complete and accurate, no liability can be accepted for any errors or omissions. Please note products are subject to continual development and may be subject to change without notice.
2. Though contents in this manual have been carefully checked, there may be inaccuracies. Please do not hesitate contact us in case of any inaccuracy.
3. Do not copy, record, reproduce or transmit the contents of this manual without prior permission from JASIC.

**Manufacturer: Shenzhen JASIC Technology Co. Ltd**

**Registered Trademark: JASIC**

**Registered Address:** No.3 Qinglan 1st Road, Pingshan District, Shenzhen, Guangdong, China

Postcode: 518118

Tel: +86 (0755) 8670 6250

Fax: +86 (0755) 27364108

Website: [www.jasictech.com](http://www.jasictech.com)

E-mail: [sales@jasictech.com](mailto:sales@jasictech.com)

# Contents

1. Safety Precautions.....	4
2. Product Overview.....	5
3. Performance Features.....	5
4. Technical Parameters.....	5
5. Installation and Operating Instructions.....	6
6. Precautions.....	8
7. Fault and Maintenance.....	8
Appendix A Packaging, Transportation and Storage.....	11
Appendix B Wiring Diagram of Complete Machine.....	12

# 1. Safety Precautions



## •Electric Shock

Install the grounding device according to the applicable standards.

Do not touch live parts when the skin is exposed, wearing wet gloves or wearing wet clothes.

Make sure you are insulated from the ground and the weldment.

Cover the cover plate before power-on; otherwise, electric shock may be caused.

Make sure your station is safe.



## •Fire

Please install this product on an incombustible object; otherwise, a fire may be caused.

Do not place combustible materials near this product; otherwise, a fire may be caused.



## •Explosion

Do not install this product where there are explosive gases; otherwise, explosion may be caused.



## •Potential Hazard Arising From Replacement of Parts

Parts must be replaced by professionals.

When replacing parts, do not to drop foreign objects such as conductor residues, screws, washers and metal rods into the machine.

After replacement of parts, ensure that internal wires of the machine are connected correctly before operation; otherwise, property damage may be caused.

## 2. Product Overview

3.5L water cooler adopts vertical duct, 18 waterway condenser and high-quality heat-resistant water pump. Featuring high lift, small caliber and large flow, it meets the cooling requirements of welding equipment.

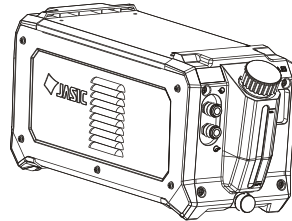

## 3. Performance Features

This product features small volume and light weight. Featuring low noise and stable flow, this product can meet the cooling requirements for MIG/TIG precision welding equipment. This product has good cooling effect and is energy-saving, environmental and pollution-free.

## 4. Technical Parameters

Note: Some parameters are acquired under experimental conditions.

Technical Parameters	Units	LC-30 COS1
Rated input voltage	V	Single-phase AC115-230V±15% 50Hz
Rated input power	W	AC115@92w AC230@115W
Volume of water tank	L	3.5
Maximum pressure	MPa	0.48
Maximum flow rate	L/min	4
Rated cooling power	KW	0.52 (1L/min)
Protection class		IP23S
Executive standard		EN IEC 60974-2/BS EN IEC60974-2
Coolant		Pure water, anti-freezing solution, mixed liquid
Operating ambient temperature	°C	Mixed liquid, pure water: 5-60 Anti-freezing solution: -20-60
Storage temperature	°C	-20-60
Noise	db	<70
Machine dimensions	mm	527*182*224
Packaging dimension	mm	630*255*315
Weight	kg	-

## 5. Installation and Operating Instructions

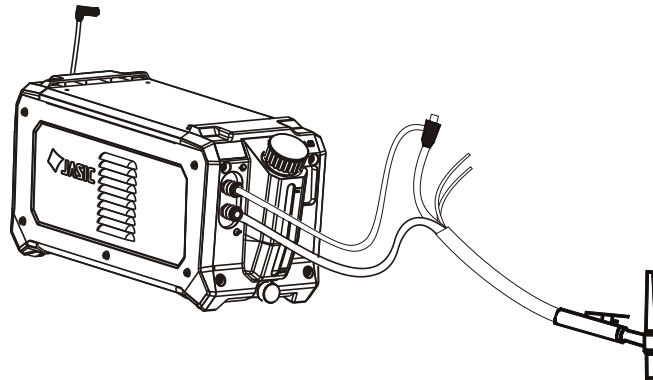

Fig. 1 Installation and connection

### Operational Instructions

- Connect the welding gun reliably (connect the red to the return pipe and the blue to the outlet pipe), uncover the water tank and add coolant (please add anti-freezing solution if the temperature is lower than 5°C). Please fill the kettle with water when it is used for the first time.
- Cover the water tank and power on it. The power light lights up, the water pump starts to work and water will flow out of the inlet and outlet pipes.

#### Notes:

1. Please ensure to connect the input cable to the host power or the power grid reliably and correctly before power-on.
2. There should be no obstacles in 0.3m of the vent of the water tank.
3. With protection class of IP23S, this product should be protected from rain in use.



**Front panel description:**

- 1 Return pipe (red)
- 2 Outlet pipe (blue)
- 3 Overheat warning light
- 4 Flow warning light
- 5 Power light
- 6 Water filling nozzle of kettle
- 7 Drainage port

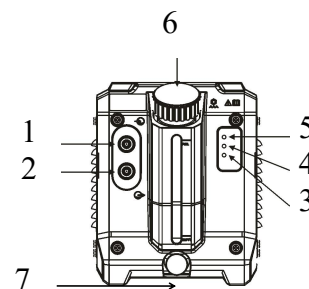

**Description of rear panel:**

- 1 Power line

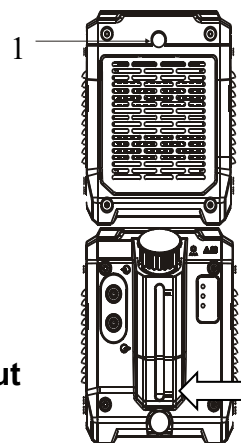

**Water level description:**

The lowest water level should be no lower than the indication line in work; otherwise, abnormalities may be caused.



**Notes:**

- 1 Please ensure to add coolant (cooling water) when the input cable is disconnected to the power grid.
- 2 The filter screen in the water filling nozzle of the kettle cannot be removed. If unfiltered coolant is added, impurities may block the waterway system and consequently the machine may be damaged.

**Drainage:**

Open the front bottom drain port for drainage.



**Note:** Please ensure to drain water when the input cable is disconnected to the power grid.

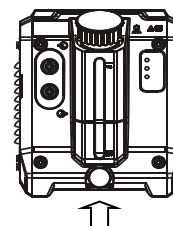

**Interface definition:**

- 1、2: AC115-230V/1~ 50Hz;
- 3, 4: Abnormal signal;
- 5: Ground wire;

**Note:** The power line is furnished with aviation plug.

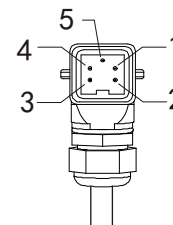

## 6. Precautions

1. Please ensure the power grid is consistent with the machine label before use, since connection of incorrect power grid may damage the machine.
2. There should be no obstacles in 0.3m of the vent of the water tank. Ensure good ventilation of the machine.
3. Please ensure the ground wire is connected to ground well.
4. Please add clean, pure and anti-corrosive coolant. Coolant containing impurities or corrosive substances may damage the machine and cause leakage and abnormalities. Welding coolant is recommended.
5. Please add anti-freezing solution when the temperature is lower than 5°C.
6. This machine cannot be used when the air contains a lot of acid, alkali and salt.

## 7. Fault and Maintenance

### Safety Warning:



**The following operations can only be carried out by operators with sufficient electrical expertise and comprehensive safety knowledge, and with valid qualification documents to demonstrate their ability and expertise. Please confirm that the input cable is disconnected to the power grid before opening the housing.**

### Routine maintenance:

- Observe the water level of the machine before use and ensure the coolant level is not lower than the lowest water level.
- Regularly inspect internal circuit of the machine and ensure to connect pipelines correctly and securely. Damaged and loose parts should be replaced and reinforced.
- Regularly clean inside of the machine. Please clean the machine under suitable air pressure in order to avoid damaging components.
- If the machine is left unused for a long time; coolant in the water tank should be drained.



**Fault Phenomenon and Solution:**

<b>Symptom</b>	<b>Corrective Action</b>
The power light does not light up, the water pump does not work, water does not flow in the water pipe and the fan does not work.	1 Inspect whether the power line is connected correctly. 2 Inspect and confirm that input cables are connected to power supply. 3 Inspect whether the patch cord of the main board is loose. If so, please tighten it
The power light lights up, the water pump does not work, water does not flow in the water pipe and the fan does not work. The flow warning light lights up.	1 Inspect whether the fan gets stuck by foreign matters. If any, remove foreign matters. 2 Inspect whether the patch cord of the main board is loose. If so, please tighten it 3 Inspect whether the main board outputs DC24V. If not, replace the main board.
The power light lights up, the water pump does not work, water does not flow in the water pipe and the fan works properly. The flow warning light lights up.	1 Inspect whether the patch cord of the main board is loose. If so, please tighten it 2 Inspect whether the main board outputs DC24V. If not, replace the main board. 3 The water pump works properly at DC24V. If the water pump does not work, it is damaged and should be replaced.
The power light lights up, the water pump works properly, water flows in the water pipe and the fan does not work.	1 Inspect whether the fan gets stuck by foreign matters. If any, remove foreign matters. 2 Inspect whether the patch cord of the main board is loose. If so, please tighten it 3 Inspect whether the main board outputs DC24V. If not, replace the main board. 4 The fans works properly at DC24V. If the fan does not work, it is damaged and should be replaced.
The power light lights up, the water pump works properly, water flows in the water pipe and the fan works properly. The flow warning light lights up.	1 Inspect whether internal lines are loose. If any, please tighten them. 2 Inspect whether the flow switch works properly. If water flows in the water pipe, the flow switch is opened. Otherwise, the flow switch is closed. In case of abnormalities, please replace the flow switch. 3 If coolant contains impurities, the flow switch will break down or be damaged. Please replace the flow switch.

<p>The power light lights up, the water pump works properly, water flows in the water pipe and the fan works properly. The temperature warning light lights up.</p>	<p>1 Inspect whether the operating power exceeds the cooling power. Please do not use operating power exceeding the cooling power. If the water temperature is too high, the machine cannot be reused before the temperature falls and the temperature warning light lights off.</p> <p>2 Inspect whether internal lines are loose. If any, please tighten them.</p> <p>3 Inspect whether the temperature switch is normal. If the water temperature is higher than the maximum temperature of the temperature switch, the temperature switch is closed. If the water temperature is lower than the minimum temperature of the temperature switch, the temperature is opened.</p>
<p>Leakage is observed.</p>	<p>1 If the joint leaks water, please reconnect and tighten it.</p> <p>2 If the condenser pipe leaks water due to corrosion, please replace the condenser. Meanwhile, please replace non-corrosive coolant.</p> <p>3 If the water pump leaks water, please replace the water pump.</p> <p>4 If the kettle leaks water, please replace the kettle.</p> <p>5 If the pulsation damper leaks water, replace the damper.</p>

## **Appendix A Packaging, Transportation and Storage**

### **A.1 Packaging**

This product is packaged individually.

### **A.2 Transportation**

In the process of handling equipment, it shall be handled with care, and it shall not be severely impacted. Moisture and rain shall be prevented during transportation.

### **A.3 Storage**

Storage temperature: -20°C-60°C.

Storage humidity: Relative humidity  $\leq$  90%.

Storage period: 12 months.

Storage condition: Stored indoors in a well-ventilated space free from corrosive gas.

## Appendix B Wiring Diagram of Complete Machine

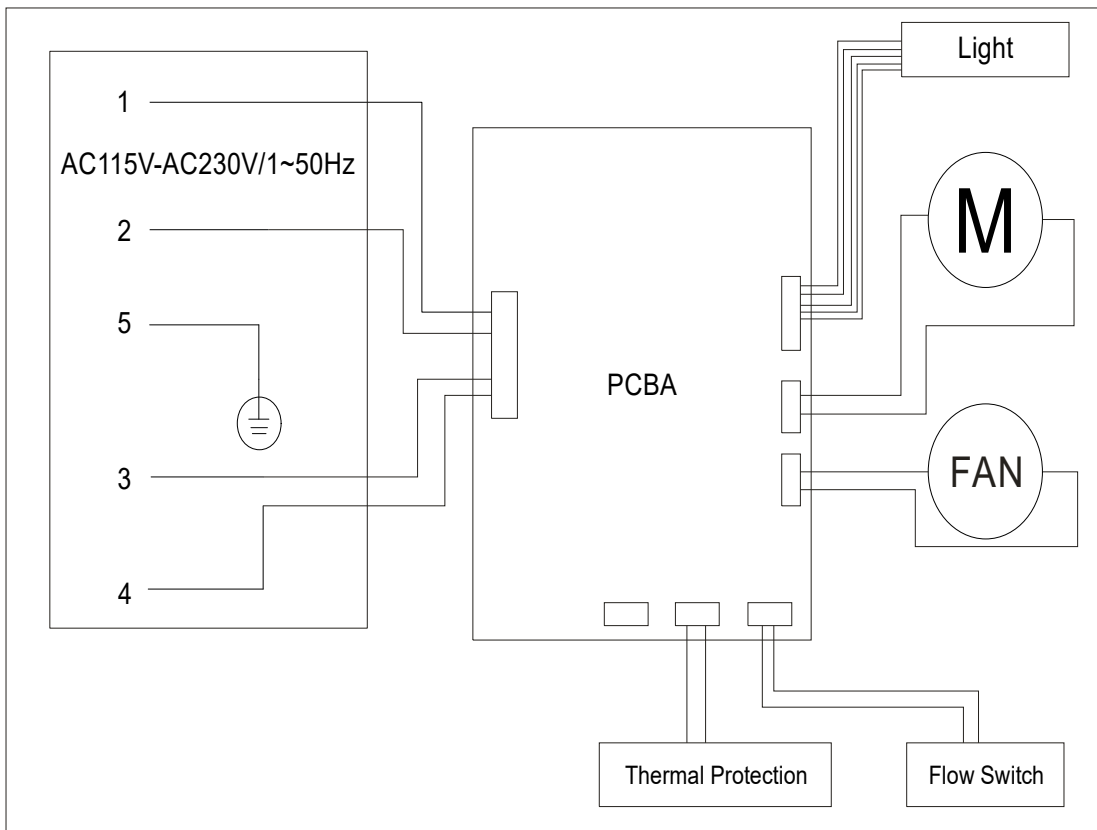

 **JASIC®** | Passionate About Your Welding

**SHENZHEN JASIC TECHNOLOGY CO., LTD.**

Address: No. 3, Qinglan 1st Road, Pingshan District, Shenzhen, Guangdong, China

Postcode: 518118

Tel: +86 (0755) 8670 6250

Fax: +86 (0755) 2736 4108

Website: [www.jasitech.com](http://www.jasitech.com)

E-mail: [sales@jasitech.com](mailto:sales@jasitech.com)

---

 @JASICTechWelding

 JASIC Technology Co., Ltd.

 @jasitech\_official