



JASIC®

EVO2.0



Operator Manual

EP-45 & EP-45SC

ClearVision
(Optional TFT-LCD screen included)



Your new product



Jasic.co.uk

Thank you for selecting this Jasic EVO 2.0 product.

This product manual has been designed to ensure that you get the most from your new product. Please ensure that you are fully conversant with the information provided paying particular attention to the safety precautions. The information will help protect yourself and others against the potential hazards that you may come across.

Please ensure that you carry out daily and periodic maintenance checks to ensure years of reliable and trouble free operation.

Please call your Jasic distributor in the unlikely event of a problem occurring. Please record below the details from your product as these will be required for warranty purposes and to ensure you get the correct information should you require assistance or spare parts.

Date purchased _____

From where _____

Serial number _____

(The serial number is normally located on the top or underside of the machine and will begin with AA)

For further information on your Jasic product warranty registration please visit:

www.jasic-warranty.co.uk

Disclaimer

Whilst every effort has been made to ensure that the information contained within this manual is complete and accurate, no liability can be accepted for any errors or omissions.

Please Note:

Products are subject to continual development and may be subject to change without notice. Regularly check our product pages at www.jasic.co.uk for revision updated operating manuals.

No part of this manual may be copied or reproduced by any means without the written permission of Wilkinson Star Limited.

CONTENTS

Index	Page
Your New Product	2
Index	3
Safety Instruction	4
General electrical safety	4
General operating safety	4
PPE	5
Welding processes lens shade selector guide	5
Fume and welding gases	6
Fire risks	6
The working environment	7
Protection from moving parts	7
Magnetic fields	7
Compressed gas cylinders and regulators	7
RF declaration	8
LF declaration	8
Materials and their disposal	9
Package and Contents	9
Description of Symbols	10
What is Plasma	11
Product Overview	12
Technical Specifications	13
Description of EP-45 (ClearVision Control Panel)	14
Description of EP-45 (Optional TFT-LCD Control Panel)	17
Description of Air Compressor	24
Installation	25
User Set-up	27
Operation	28
Operation - Modes of Cutting	31
Plasma Torch Breakdown	34
General Cutting Information	35
Cut Quality	36
Troubleshooting	38
Troubleshooting - Error Codes	39
Troubleshooting - Plasma Cutting Problems	40
Maintenance	41
Options and Accessories	42
WEEE Disposal	43
RoHS Compliance Declaration	43
UKCA Declaration of Conformity	44
EC Declaration of Conformity	45
Statement of Warranty	46
Schematics	47
Notes	48
Jasic Contact Details	50

SAFETY INSTRUCTIONS



These general safety norms cover both arc welding machines and plasma cutting machines unless otherwise noted. The user is responsible for installing and operating the equipment in accordance with the enclosed instructions.

It is important that users of this equipment protect themselves and others from harm, or even death. The equipment must only be used for the purpose it was designed for. Using it in any other way could result in damage or injury and in breach of the safety rules.

Only suitably trained and competent persons should operate the equipment.

Pacemaker wearers should consult their doctor prior to using this equipment.

PPE and workplace safety equipment must be compatible for the application of the work involved.

Always carry out a risk assessment before carrying out any welding or cutting activity.

General electrical safety



Danger
Electric shock risk

The equipment should be installed by a qualified person and in accordance with current standards in operation.

It is the users responsibility to ensure that the equipment is connected to a suitable power supply. Consult your utility supplier if required.

Do not use the equipment with the covers removed. Do not touch live electrical parts or parts which are electrically charged. Turn off all equipment when not in use.

In the case of abnormal behaviour of the equipment, the equipment should be checked by a suitably qualified service engineer.

If earth bonding of the work piece is required, bond it directly with a separate cable with a current carrying capacity capable of carrying the maximum capacity of the machine current.

Cables (both primary supply and welding) should be regularly checked for damage and overheating.

Never use worn, damaged, under sized or poorly jointed cables.

Insulate yourself from work and earth using dry insulating mats or covers big enough to prevent any physical contact.

Never touch the electrode if you are in contact with the work piece return.

Do not wrap cables over your body.

Ensure that you take additional safety precautions when you are welding in electrically hazardous conditions such as damp environments, wearing wet clothing and metal structures.

Try to avoid welding in cramped or restricted positions.

Ensure that the equipment is well maintained. Repair or replace damaged or defective parts immediately.

Carry out any regular maintenance in accordance with the manufacturers instructions.

The EMC classification of this product is class A in accordance with electromagnetic compatibility standards CISPR 11 and IEC 60974-10 and therefore the product is designed to be used in industrial environments only.

WARNING: This class A equipment is not intended for use in residential locations where the electrical power is provided by a public low-voltage supply system. In those locations it may be difficult to ensure the electromagnetic compatibility due to conducted and radiated disturbances.

General operating safety



Never carry the equipment or suspend it by the carrying strap or handles during welding.

Never pull or lift the machine by the welding torch or other cables.

Always use the correct lift points or handles. Always use the transport under gear as recommended by the manufacturer.

Never lift a machine with the gas cylinder mounted on it.

If the operating environment is classified as dangerous, only use S-marked welding equipment with a safe idle voltage level. Such environments may be for example: humid, hot or restricted accessibility spaces.

SAFETY INSTRUCTION

CAUTION Use of Personal Protective Equipment (PPE)

PPE REQUIRED AT ALL TIMES Welding arc rays from all welding and cutting processes can produce intense, visible and invisible (ultraviolet and infrared) rays that can burn eyes and skin.

- Wear an approved welding helmet fitted with an appropriate shade of filter lens to protect your face and eyes when welding, cutting or watching.
- Wear approved safety glasses with side shields under your helmet.
- Never use any equipment that is damaged, broken or faulty.
- Always ensure there are adequate protective screens or barriers to protect others from flash, glare and sparks from the welding and cutting area.
- Ensure that there are adequate warnings that welding or cutting is taking place.
- Wear suitable protective flame resistant clothing, gloves and footwear.
- Ensure adequate extraction and ventilation is in place prior to welding and cutting to protect users and all workers nearby.
- Check and be sure the area is safe and clear of flammable material before carrying out any welding or cutting.



Some welding and cutting operations may produce noise. Wear safety ear protection to protect your hearing if the ambient noise level exceeds the local allowable limit (e.g: 85 dB).

Welding and Cutting Lens Shade Selector Guide

WELDING CURRENT	MMA ELECTRODES	MIG LIGHT ALLOY	MIG HEAVY METALS	MAG	TIG ALL METALS	PLASMA CUTTING	PLASMA WELDING	GOUGING ARC/AIR			
10	8	10	10	10	9	11	10	10			
15											
20	9				10				10	10	11
30											
40											
60	10	11	11	11	12						
80											
100	11	11	11	11	12	13					
125											
150		12	12	12	12	13					
175											
200			12	12	12	13	13	11			
225											
250	13	13		13	13	12					
275											
300		13		14	13	14	14	13			
350											
400	14		14	14	14	14	14				
450											
500			14	15	14	15	15	15			

SAFETY INSTRUCTION

Safety against fumes and welding gases



Warning
Fumes and
Gases

The HSE have identified welders as being an 'at risk' group for occupational diseases arising from exposure to dusts, gases, vapours and welding fumes. The main identified health effects are pneumonia, asthma, chronic obstructive pulmonary disease (COPD), lung and kidney cancer, metal fume fever (MFF) and lung function changes.

During welding and hot cutting 'hot work' operations, fumes are produced which are collectively known as welding fume. Depending upon the type of welding process being performed, the resultant fume generated is a complex and highly variable mixture of gases and particulates. Regardless of the length of welding being carried out, all welding fume, including mild steel welding requires suitable engineering controls to be in place which is usually Local Exhaust Ventilation (LEV) extraction to reduce the exposure to welding fume indoors and where LEV does not adequately control exposure it should also be enhanced by using suitable respiratory protective equipment (RPE) to assist with protecting against residual fume.

When welding outdoors appropriate RPE should be used.

Prior to undertaking any welding tasks an appropriate risk assessment should be carried out to ensure expected control measures are in place.

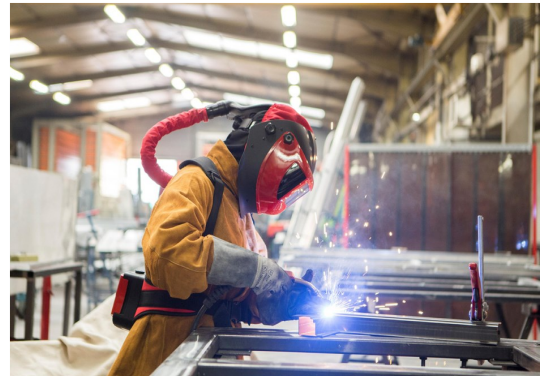

An example of personal fume protection

Locate the equipment in a well-ventilated position and keep your head out of the welding fume.

Do not breathe in the welding fume.

Ensure the welding zone is well-ventilated and provision should be made for suitable local fume extraction system to be in place.

If ventilation is poor, wear an approved airfed welding helmet or respirator.

Read and understand the Material Safety Data Sheets (MSDS's) and the manufacturer's instructions for metals, consumable, coatings, cleaners and de-greasers.

Do not weld in locations near any de-greasing, cleaning or spraying operations.

Be aware that heat and rays of the arc can react with vapours to form highly toxic and irritating gases.

For further information please refer to the HSE website www.hse.gov.uk for related documentation.

Precautions against fire and explosion



Caution
Risk of fire

Avoid causing fires due to sparks and hot waste or molten metal.

Ensure that appropriate fire safety devices are available near the welding and cutting area.

Remove all flammable and combustible materials from the welding, cutting and surrounding areas.

Do not weld or cut fuel and lubricant containers, even if empty. These must be carefully

cleaned before they can be welded or cut.

Always allow the welded or cut material to cool before touching it or placing it in contact with combustible or flammable material.

Do not work in atmospheres with high concentrations of combustible fumes, flammable gases and dust.

Always check the work area half an hour after cutting to make sure that no fires have begun.

Take care to avoid accidental contact of the torch electrode to metal objects, as this could cause arcs, explosion, overheating or fire.

Know and understand your fire extinguishers

	Water	Foam spray	ABC powder	Carbon dioxide	Wet chemical
<i>Symbols found on fire extinguishers & what they mean</i>					
Flammable Wood, paper & textiles	✓	✓	✓	✗	✓
Flammable liquids	✗	✓	✓	✓	✗
Flammable gases	✗	✗	✓	✗	✗
Electrical contact	✗	✗	✓	✓	✗
Cooling oil & fats	✗	✗	✗	✗	✓

SAFETY INSTRUCTION

The working environment



Ensure the machine is mounted in a safe and stable position allowing for cooling air circulation.
Do not operate equipment in an environment outside the laid down operating parameters.
The welding power source is not suitable for use in rain or snow.

Always store the machine in a clean, dry space.

Ensure the equipment is kept clean from dust build up.

Always use the machine in an upright position.

Protection from moving parts



When the machine is in operation keep away from moving parts such as motors and fans.

Moving parts, such as the fan, may cut fingers and hands and snag garments.

Protections and coverings may be removed for maintenance and managed only by qualified personnel after first disconnecting the power supply cable.

Replace the coverings and protections and close all doors when the intervention is finished and before starting the equipment.

Take care to avoid getting fingers trapped when loading and feeding wire during set up and operation.

When feeding wire be careful to avoid pointing it at other people or towards your body.

Always ensure machine covers and protective devices are in operation.

Risks due to magnetic fields



The magnetic fields created by high currents may affect the operation of pacemakers or electronically controlled medical equipment.

Wearers of vital electronic equipment should consult their physician before beginning any arc welding, cutting, gouging or spot welding operations.

Warning
Strong magnetic field

Do not go near welding equipment with any sensitive electronic equipment as the magnetic fields may cause damage.

Keep the torch cable and work return cable as close to each other as possible throughout their length.

This can help minimise your exposure to harmful magnetic fields.

Do not wrap the cables around the body.

Handling of compressed gas cylinders and regulators



Mishandling gas cylinders can lead to rupture and the release of high pressure gas.

Always check the gas cylinder is the correct type for the welding to be carried out.

Always store and use cylinders in an upright and secure position.

Danger
Compressed gas

All cylinders and pressure regulators used in welding operations should be handled with care.

Never allow the electrode, electrode holder or any other electrically “hot” parts to touch a cylinder.

Keep your head and face away from the cylinder valve outlet when opening the cylinder valve.

Always secure the cylinder safely and never move with regulator and hoses connected.

Use a suitable trolley for moving cylinders.

Regularly check all connections and joints for leaks.

Full and empty cylinders should be stored separately.

Never deface or alter any cylinder

SAFETY INSTRUCTIONS

Fire awareness



The cutting and welding process can cause serious risks of fire or explosion. Cutting or welding sealed containers, tanks, drums or pipes can cause explosions. Sparks from the welding or cutting process can cause fires and burns. Check and risk assess the area is safe before doing any cutting or welding. Ventilate all flammable or explosive vapour from the workplace.

Remove any and all flammable materials away from the working area. If necessary, cover flammable materials or containers with approved covers (following manufacturers instructions) if unable to remove from the immediate area.

Do not cut or weld where the atmosphere may contain flammable dust, gas or liquid vapour. Always have the appropriate fire extinguisher nearby and know how to use it.

Hot parts



Always be aware that material being cut or welded will get very hot and hold that heat for a considerably long time which will cause severe burns if the appropriate PPE is not worn. Do not touch hot material or parts with bare hands.

Always allow for a cooling down period before working on material recently cut or welded. Use the appropriate insulated welding gloves and clothing to handle hot parts to prevent burns.

Noise awareness



The cutting and welding process can generate noise that can cause permanent damage to your hearing. Noise from cutting and welding equipment can damage hearing.

Always protect your ears from noise and wear approved and appropriate ear protection if noise levels are high.

Consult with your local specialist if you are unsure how to test for noise levels.

RF Declaration



Equipment that complies with directive 2014/30/EU concerning electromagnetic compatibility (EMC) and the technical requirements of EN60974-10 is designed for use in industrial buildings and not for domestic use where electricity is provided via the low voltage public distribution system.

Difficulties may arise in assuring class A electromagnetic compatibility for systems installed in domestic locations due to conducted and radiated emissions.

In the case of electromagnetic problems, it is the responsibility of the user to resolve the situation.

It may be necessary to shield the equipment and fit suitable filters on the mains supply.

LF Declaration



Consult the data plate on the equipment for the power supply requirements.

Due to the elevated absorbance of the primary current from the power supply network, high power systems affect the quality of power provided by the network. Consequently, connection restrictions or maximum impedance requirements permitted by the network at the public network connection point must be applied to these systems.

In this case, the installer or the user is responsible for ensuring the equipment can be connected, consulting the electricity provider if necessary.

SAFETY INSTRUCTION

Materials and their disposal



Welding equipment is manufactured with BSI published standards meeting CE requirements for materials which do not contain any toxic or poisonous materials dangerous to the operator. Do not dispose of the equipment with normal waste.



The European Directive 2012/19/EU on Waste Electrical and Electronic Equipment states that electrical equipment that has reached its end of life must be collected separately and returned to an environmentally compatible recycling facility for disposal.

For more detailed information please refer to the HSE website www.hse.gov.uk

PACKAGE CONTENTS AND UNPACKING

Supplied within your new Jasic EVO product package will be the following items with each model.

Use care when unpacking the contents and ensure all items are present and not damaged.

If damage is noted or items are missing, please contact the supplier in the first instance and before installing or using the product.

Record the product model, serial numbers and purchase date in the information section found on the inside front page of this operating manual.

Jasic EVO Cut 45 PFC

EP-45 PFC Power Source

IPT-60 Plasma Torch 6m

Work Return Lead

USB Stick with Operating Manual

Jasic EVO Cut 45SC PFC

EP-45SC PFC Power Source

Jasic EVO compressor

IPT-60 Plasma Torch 6m

Work Return Lead

USB Stick with Operating Manual



Please Note: Package contents may vary depending on country location and package part number purchased

DESCRIPTION OF SYMBOLS

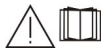

Read this operation manual carefully before use.



Warning in operation.

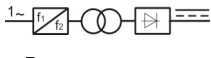

Single-phase static frequency converter-transformer rectifier.

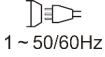

1 ~ 50/60Hz Symbol of single-phase AC power supply and rated frequency.



Can be used in the environment which has high risk of electric shock.

IP

Degree of protection, such as IP23S.

U₁

Rated AC input voltage (with tolerance $\pm 15\%$).

I_{1max}

Rated maximum input current.

I_{1eff}

Maximum effective input current.

X

Duty cycle, The ratio of given duration time/the full-cycle time.

U₀

No-load voltage, Open circuit voltage of secondary winding.

U₂

Load voltage.

H

Insulation class.



Do not dispose of electric waste with other ordinary waste. Protect our environment.



Electric shock risk warning.



Current unit "A"



Overheat protection indicator.



Overcurrent protection indicator.



2T continuous cutting



4T continuous cutting



Mesh cutting



Cutting mode switching



Gas test check indicator



Gas check test button

WHAT IS PLASMA?

- Plasma is commonly described as the fourth state of matter (i.e. solid, liquid, gas then plasma).
- If you increase gas to an extremely high temperature you get the fourth state plasma, the energy begins to break apart the gas molecules and the atoms begin to split. Normal atoms are made up of protons and neutrons in the nucleus surrounded by a cloud of electrons. In plasma, the electrons separate from the nucleus. Once the energy of heat releases the electrons from the atom, the electrons begin to move around quickly.

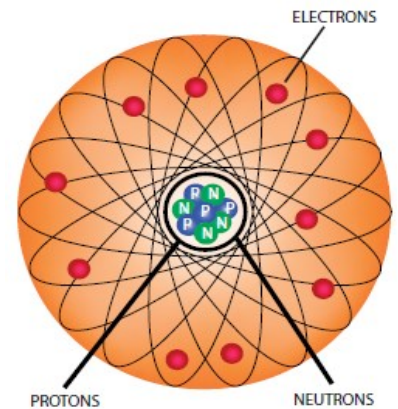

The electrons are negatively charged and they leave behind their positively charged nuclei. These positively charged nuclei are known as ions. When the fast-moving electrons collide with other electrons and ions, they release vast amounts of energy.

This energy is what gives plasma its unique status and unbelievable cutting power.

- Plasma is a gas which has been heated to an extremely high temperature and ionized so that it becomes electrically conductive. An example of naturally occurring plasma is lightning.
- The plasma arc cutting, gouging and welding processes uses plasma to transfer an electrical arc to the work piece, the electrically conductive gas will transfer the energy from the plasma power source through a plasma torch to the material being cut.

- The plasma arc cutting process basics can be seen in the illustration. The basic principle is that the arc is formed between the electrode and the work piece by forcing the plasma gas and the electrical arc through a small orifice within the copper tip. This will increase the speed and temperature of the plasma exiting the tip. The temperature of the plasma is in excess of 15000°C and the speed can approach that of sound. This plasma gas flow in conjunction with the high temperature enables a deeply penetrating plasma jet to cut through the work piece material and at the same time molten material is blown away from the cut.

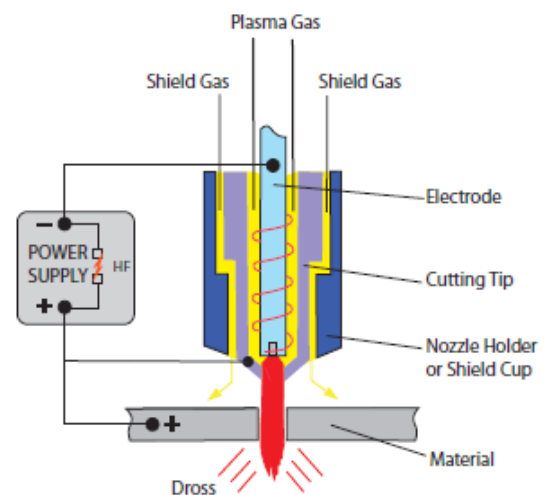

- The process differs from the oxy-fuel process in that the plasma process works by using the high temperature arc to melt the metal to be cut. With the oxy-fuel process, the oxygen oxidises the metal to be cut and the heat from the exothermic reaction melts the metal. So, unlike the oxy-fuel process, the plasma process can be used to cut metals including those which form protective refractory oxides such as aluminium, stainless steel, non-ferrous alloys and cast iron.
- The output current (amps) of the power supply will determine the cutting thickness and speed capabilities of the plasma machine.
- While the primary goal of plasma arc cutting is the separation of metal, plasma arc gouging is used to remove metals to a controlled depth and width.
- Plasma machines consist of a power supply, an arc starting circuit, a plasma torch and a compressed air supply.
- Direct current (DC) straight polarity is used for plasma cutting with the electrode being - negative and the tip/work piece being + positive.

PRODUCT OVERVIEW

The Jasic EVO plasma cutting inverter range of machines have been designed as portable cutting power supplies incorporating the most advanced inverter, offering excellent performance.

The EVO Plasma machines generate a stable DC arc that will easily cut through carbon steel, low alloy steel, stainless steel and other materials.

Plasma torch length and post-flow time can be adjusted separately to offer optimum performance for a wide range of applications.

The internal structure and air flow design enhances the dissipation of heat generated by the power components, thereby improving the duty cycle.

Due to its unique air duct heat dissipation design, this will help to prevent dust being up drawn in by the cooling fan from damaging key power components and control circuits, thereby greatly improving the reliability and performance of the plasma machine.

With non HF pilot arc starting and combined with the 6M IPT60 plasma torch offers excellent plasma arc ignition which will cut through rusty and painted metals as well as ferrous and non ferrous material easily which can effectively prolong the lifespan of the electrode and cutting tip of the plasma cutting torch.

The unique ClearVision display offers the operator clear and informative control data for the welding plasma cutting process offered, an optional TFT-LCD upgrade version is also available.

Plasma cutting technology can be widely used in various industries involving metal cutting such as boiler and pressure vessel manufacturing, chemical container manufacturing, power plant installation and construction industry, metallurgy, chemical engineering, aerospace, automobile and engineering vehicles manufacturing and construction facilities.



Jasic Cut EP-45 and EP-45SC Product Features:

- The Jasic EVO range of plasma machines are compact, ergonomic designed with advanced inverter technology that offers excellent, smooth and precise cutting characteristics that is ideal process for cutting steel, stainless, copper, cast iron and aluminium
- Wide voltage inverter that will function on mains input supplies of 95V ~ 265V AC 50Hz
- The Cut EP-45 has inbuilt advanced energy saving PFC circuitry (Power Factor Correction) which are generator friendly (AVR)
- The Cut EP-45SC also has an 'integrated' compressor that offers the ultimate in portable plasma cutting whether in the workshop or when working onsite.
- ClearVision digital control panel (as standard) with integrated large LED digital ammeter display for accurate variable current setting or upgrade to the 'optional' TFT-LCD digital control panel to have a full LED display that offers additional user facilities
- Advanced SurePlasma technology that offers consistent (non HF) plasma arc ignition making the IPT60 plasma torch the ideal partner
- Cutting speeds are increased 1.8 times when compared with oxy acetylene cutting
- Convenient single carry handle, making the EVO plasma machine very portable and easy to manoeuvre, both in the workshop and onsite
- Easy to access pressure gauge with adjustable regulator
- Features such as mesh/grid cutting, gas check and 2T/4T latch facilities
- Cut EP-45 machines offer a clean cut capacity of 14mm and severance cut of 20mm
- Optional circle cutting guide kit available
- Optional CNC interface (suitable for most cutting tables)

TECHNICAL SPECIFICATIONS

Parameter	Unit	Jasic Arc EP-45 PFC	Jasic Arc EP-45SC PFC
Rated input (U1)	V & Hz	AC 95 ~ 265V 50/60	AC 95 ~ 265V 50/60
Rated input current (I _{eff})	A	115V - 20 230V - 11.5	115V - 26 230V - 15
Rated input current (I _{max})	A	115V - 31 230V - 23	115V - 37 230V - 27
Rated input power	kVA	115V - 3.6 230V - 5.3	115V - 10 * 230V - 6.2
Cutting current range	A	115V - 20 ~ 30 230V - 20 ~ 45	115V - 20 ~ 30 230V - 20 ~ 45
Rated operating voltage	V	115V - 92 230V - 98	115V - 92 230V - 98
Rated duty cycle (X) (rated at 40°C)	%	30A @ 25%	45A @ 25%
Clean cut	mm	115V - 6 230V - 15	115V - 5 230V - 12
Severance cut	mm	115V - 12 230V - 22	115V - 10 230V - 20
Pierce cut	mm	115V - 4 230V - 12	115V - 3 230V - 10
No load voltage (OCV) (U ₀)	V	300	300
Plasma Torch	-	IPT60 (6m)	IPT60 (6m)
Pilot Arc start mode	V	Non HF	Non HF
Efficiency	%	86	86
Idle state power	W	< 50	< 50
Power factor	cosφ	0.99	0.99
Standard	-	EN60974-1	EN60974-1
Protection class	IP	IP23S	IP23S
Insulation class	-	H	H
Noise	Db	< 110	< 110
Operating temperature range	°C	-10 ~ +40	-10 ~ +40
Storage temperature	°C	-25 ~ +55	-25 ~ +55
Size (with handle)	mm	546 x 166 x 341	547 x 187 x 558
Net weight	Kg	10	26.6
Overall weight	Kg	14.5	33.6

* When using the EP-45SC via a portable transformer, please ensure that you use a suitably sized 115v transformer or the add-on compressor start up performance will be impacted.

Please Note

Due to variations in manufactured products all claimed performance ratings, capacities, measurements, dimensions and weights quoted are approximate only. Achievable performance and ratings when in use can depend upon correct installation, applications and use along with regular maintenance and service.

DESCRIPTION OF MACHINE (CLEARVISION CONTROL PANEL)

Front view Jasic Cut EP-45

1. Machine carry handle
2. Digital user control panel (see lower down for further information)
3. N/A
4. "-" Output terminal, The connection for the work clamp *
5. Euro style connector, the plasma torch connection (see page 27 for fitting instructions)
6. 4 pin outlet socket (for optional compressor)
7. Input power cable
8. Air supply hose

* Dinse socket size is 15-25mm

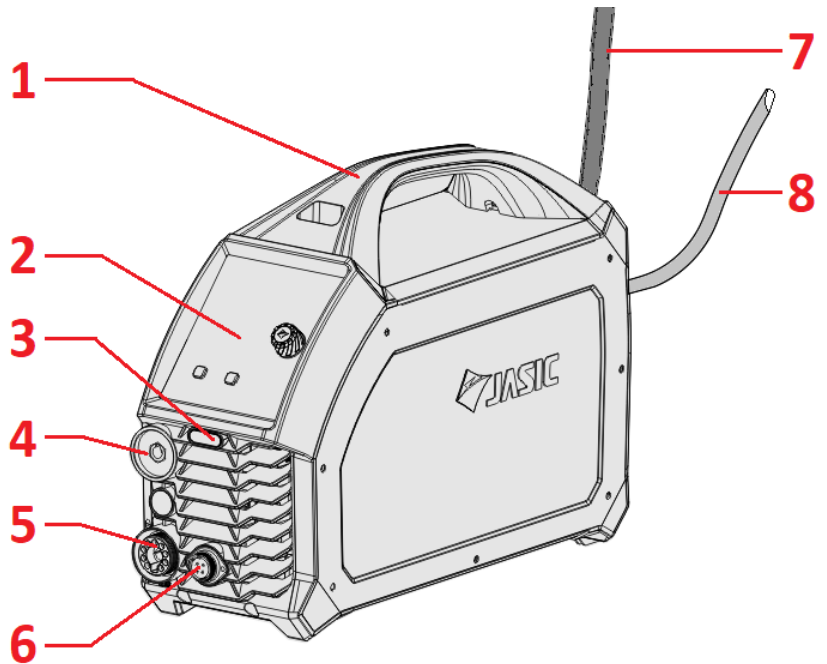

Rear view Jasic Cut EP-45

9. Machine carry handle
10. Input air regulator - Adjustment knob
11. Input air regulator - Pressure gauge
12. Input air regulator - Compressed air inlet
13. Machines ON/OFF power switch
14. Rear panel with integrated cooling vents
15. Input power cable

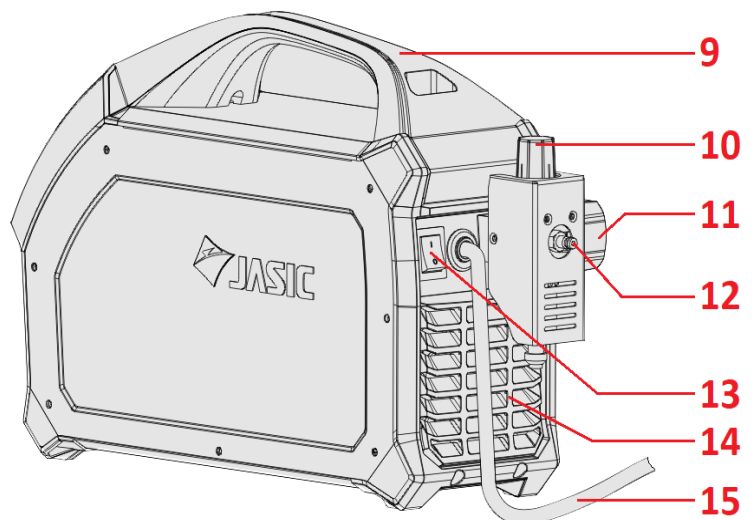

Control panel view Jasic Cut EP-45

16. Parameter and error code display area
17. Warning indicators
18. Cutting mode selection area and selector button
19. Parameter adjustment control dial and control button
20. Gas test check button and indicator

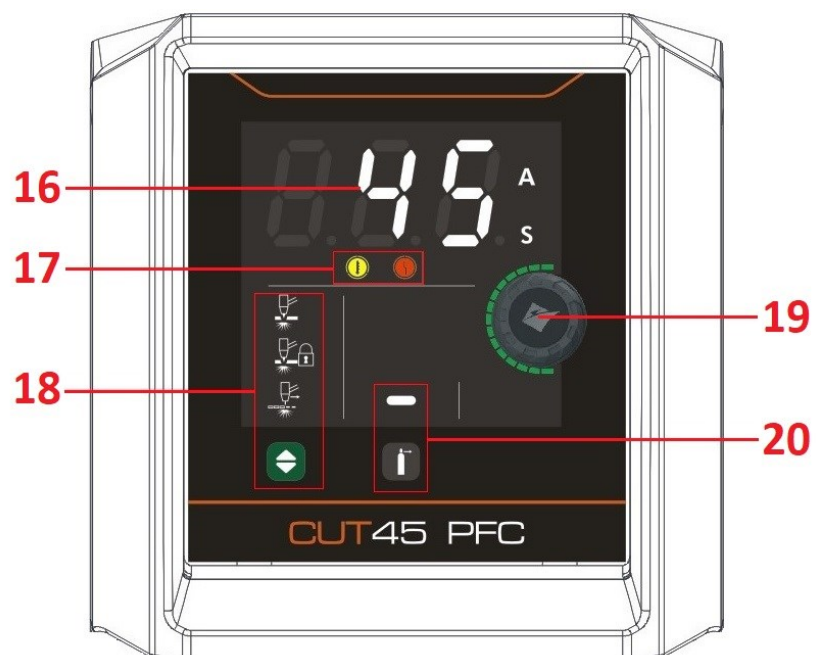

DESCRIPTION OF (CLEARVISION CONTROL PANEL)

- A. Current, parameter and error code display area
- B. Warning indicators
- C. Parameter adjustment knob and button
- D. Cutting mode selection options
- E. Cutting mode selection button
- F. Gas test check button with indicator above





A. Display of parameters and error codes

- Displays cutting and preset current settings
- When the factory reset is activated, a countdown is displayed.
- In engineers mode, parameter settings and their associated adjustment settings.
- The machines serial number will be displayed when instructed.



B. Warning indicators

-  The overheat indicator light indicates the machine has entered overheat protection and has stopped output, once the machine has cooled down output will be reactivated.
-  The over-current indicator light indicates the machine has entered over-current protection and has stopped output. Turn the machine off and back on again to reset.

C. Parameter adjustment knob

- Rotate the adjusting knob to adjust the parameters.
- Rotating the adjusting knob clockwise increases the parameter value, and rotating the adjusting knob counterclockwise decreases the parameter value.
- When the adjusting knob is rotated the adjusted parameters are displayed in the parameter display area.



D, E Selection of cutting modes



Press the cutting mode selection button while not cutting to switch between the three cutting modes as offered, 2T, 4T and mesh cutting.



If the indicator is on, it indicates the machine is currently in 2T cutting mode.



If the indicator is on, it indicates the machine is currently in 4T cutting mode.



If the indicator is on, it indicates the machine is currently in mesh cutting mode.

F. Gas check test function

- Press the gas check button (B) while not in cutting state.
- When the indicator (A) is lit, the machine is in gas check mode.
- Press the gas check button again or wait 20 seconds . After the indicator light goes out, the machine has exited gas check mode.

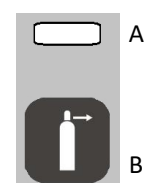



Please Note:

When in any cutting mode, the display window will display the preset cutting current, which can be set by the operator by rotating the adjustment knob clockwise to increase the current or anti clockwise to decrease the cutting current. Adjustment cutting current range is 20 ~ 45 amps in 230V mode.

DESCRIPTION OF 'CLEARVISION' CONTROL PANEL

Engineer mode



1. Press and hold the parameter adjustment knob  for 5 seconds when not cutting to enter engineers mode.
2. After pressing for 1 second, the display window will count down from 3, then the machine will enter engineer mode. If you release the button during that time you will exit the countdown and you will not enter engineers mode.
3. Engineers mode:
 - F01: Standby time selection; 0, 5, 10, or 15, (unit is minutes), 0 means that the standby function is not enabled. (factory setting is 10)
 - F02: Input over-voltage protection enabled; 0 means the function is off, 1 means the function is on. (Factory setting is 0)
 - F03: Post-flow time adjustment; 0 ~ 60 seconds. (factory setting is 15)
 - F04: N/A
- 4) After adjusting the parameters, press the cutting mode selection button  to save and exit.

Restoring factory settings

- 1) Press and hold the cutting mode selection button  for 5 seconds when not cutting to restore factory mode.
- 2) After 1 seconds, the display window will count down from 3. After completion, factory settings are restored. If you release the button before the countdown has finished you will exit the process and exit without restoring factory settings.
- 3) Factory settings:

Cutting mode:	2T continuous cutting
Cutting current:	Rated maximum
Post-flow time:	15 seconds

Displaying the serial number

- 1) Press and hold the cutting mode selection button  and parameter adjustment knob  for 5 seconds at the same time when not cutting to enter serial number display mode.
- 2) The serial number of the machine is now displayed in the display window. To see the full serial number you have to rotate the control dial 9 times.
- 3) Press any button to exit.

Please Note:

When in any cutting mode, the display window will display the preset current cutting current, which can be set by the operator by rotating the adjustment knob clockwise to increase the current or anti clockwise to decrease the cutting current.

DESCRIPTION OF MACHINE (TFT-LCD CONTROL PANEL)

Front view Jasic Cut EP-45

1. Machine carry handle
2. LCD Digital user control panel (see lower down for further information)
3. N/A
4. "-" Output terminal, The connection for the work clamp *
5. Euro style connector, the plasma torch connection (see page 27 for fitting instructions)
6. 4 pin outlet socket (for optional compressor)
7. Input power cable
8. Air supply hose

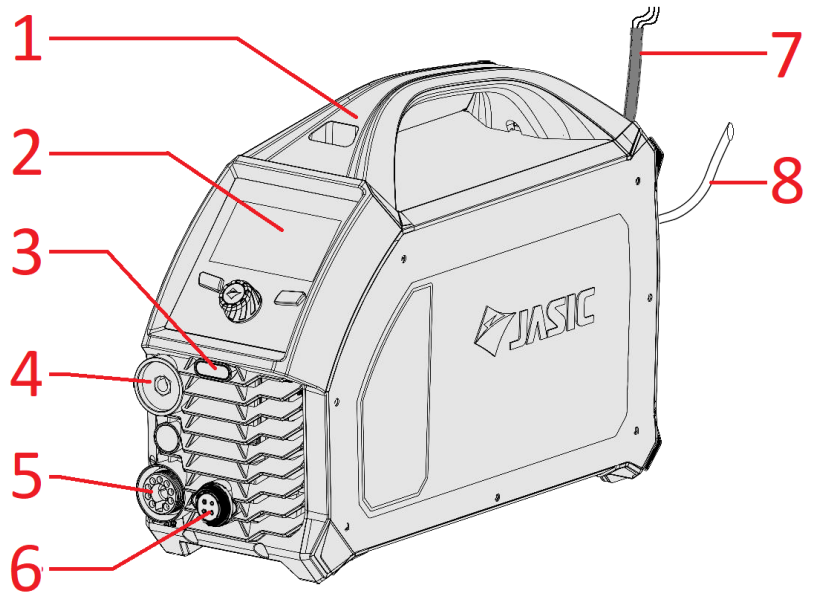

* Dinse socket size is 15-25mm

Rear view Jasic Cut EP-45

9. Machine carry handle
10. Input air regulator - Adjustment knob
11. Input air regulator - Pressure gauge
12. Input air regulator - Compressed air inlet
13. Machines ON/OFF power switch
14. Rear panel with integrated cooling vents
15. Input power cable

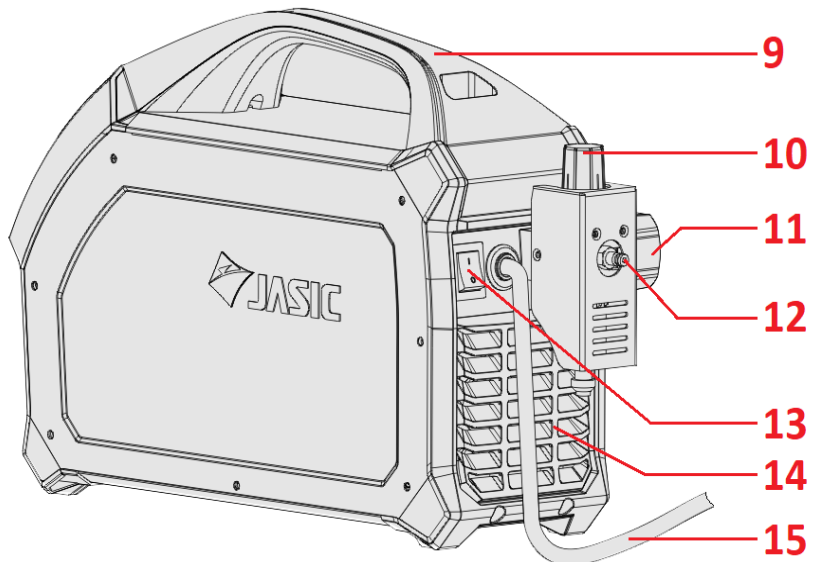

Control panel view Jasic Cut EP-45

16. Home Button: Pressing this button will take you directly to the home screen (as shown)
17. The parameter control dial is also a control button which when pressed 'confirms' entry to another screen option or parameter setting
18. LCD screen: Displays the functions, parameter and error codes to the operator
19. Return button: Pressing this button will take you back to the previous screen option
20. Parameter adjustment control dial: By rotating this dial it allows the user to scroll through or to make parameter changes that are shown via the screen

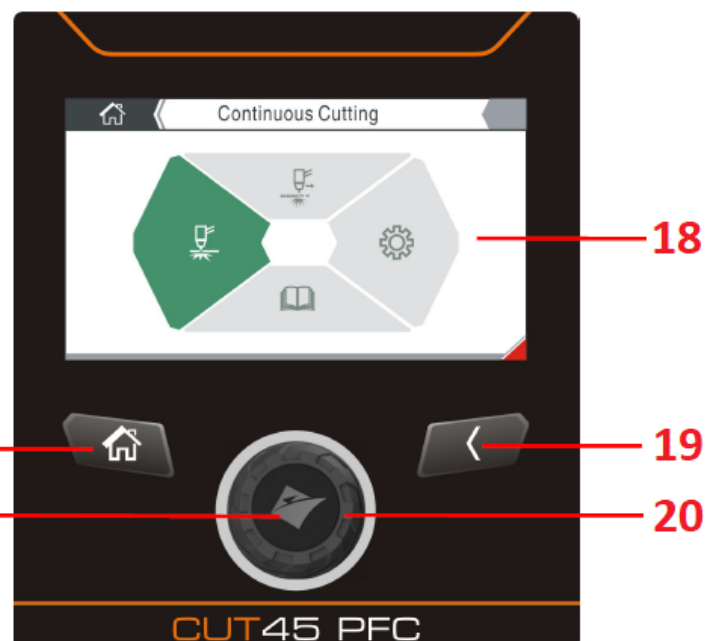

DESCRIPTION OF 'TFT-LCD' CONTROL PANEL

Display screen

The display screen offers the operator a wealth of information including operation mode, parameters that include, cutting current, post-flow time and post-flow gas.

The home screen is shown right and using the adjustment dial allows you to navigate through the machines options.

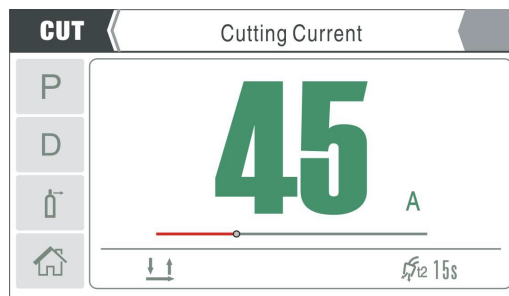

Parameter adjustment knob

Rotating the control dial clockwise or anti-clockwise allows the operator to scroll through the functions of the machine, increases or decreases parameter values including cutting current and when these parameters are adjusted the values are shown in the display screen. (This is also reflected with the green LED line around the dial also increasing or decreasing respectively).



Home Button

Pressing the home button at any time will take you directly back to the home screen which is shown in the display screen image below.



Return Button

The return button will take you back to the previous screen and the 'upper' level of the function you were within.



Display screen options

Home Screen

Upon pressing the Home button  you will be taken to the home screen (as shown right). From here you can rotate the control dial to highlight the option you require and to select, simply press the control dial to access: cutting mode, settings or operating information.

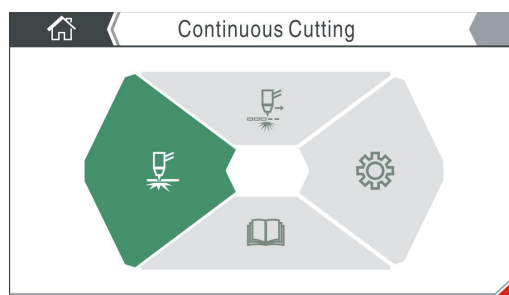

Selecting Cutting Modes

Before commencing any cutting, press the Home button to return to the home page, then rotate the control dial to select either continuous cut or mesh cutting mode, then press the control dial to select the required cutting mode (see page 30 for further details).

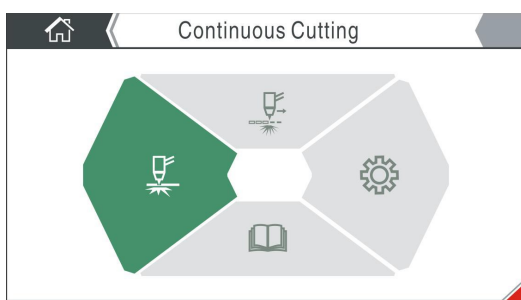

Continuous Cut Mode

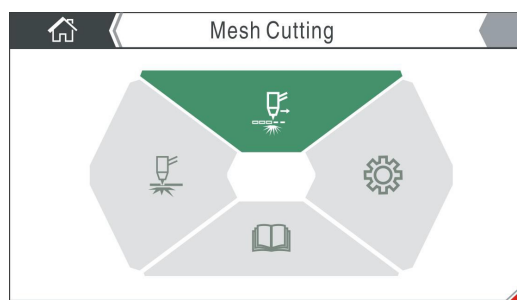

Mesh Cutting Mode

DESCRIPTION OF 'TFT-LCD' CONTROL PANEL

Display screen options

Cutting current configuration

Whether you access either continuous or mesh cutting mode the display window will show the cutting current (as shown right). By rotating the control dial you will adjust the cutting current value.

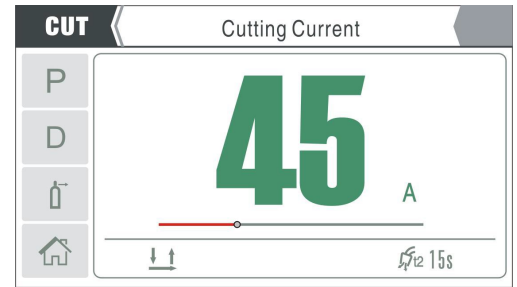

2T/4T function settings

2T and 4T torch trigger (latch) selection is a useful function when carrying out longer cuts.

When cutting in 4T mode you can remove your finger off the torch trigger and the arc will remain on until you either press the torch trigger again or you remove the plasma arc away from the material being cut.

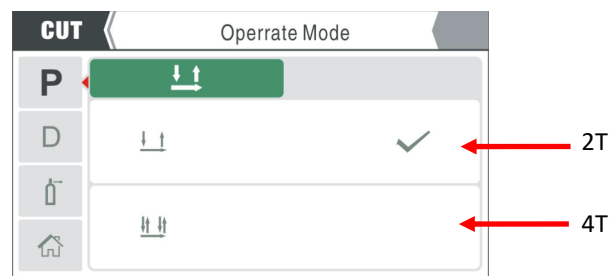
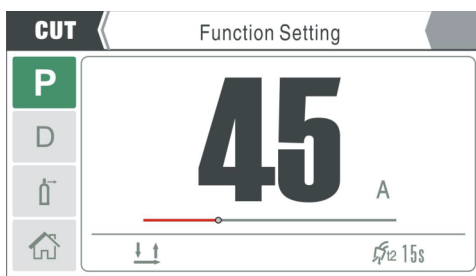

When in the 'Continuous Cut' mode, press the control dial to enter the icon options on the left and scroll to 'P' and again press the control dial. From here you can select either 2T or 4T.

Please Note: 2T/4T (4T) is not available in grid cutting mode.

Cutting torch length and post-flow time configuration

Whether you are in 'continuous' or 'mesh cutting' modes you can enter the 'D' tab which takes you into both plasma torch length selection and post gas time

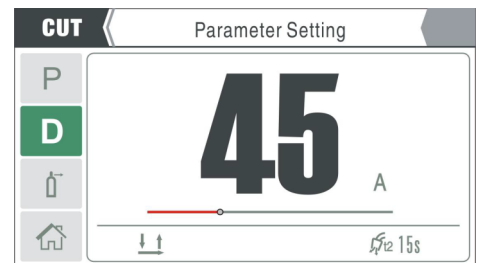

The first tab highlighted right is the parameter settings that allows you to select the plasma torch length that is fitted to the machine.

You can select torch lengths as follows:

0, 6M, 10M, 15M and 20M (0, 20, 33, 49 and 66 feet) with 0 being the auto setting, which measures the resistance of the plasma torch cable and automatically sets the torch length accordingly to ensure pilot current and air flow time is accordingly.

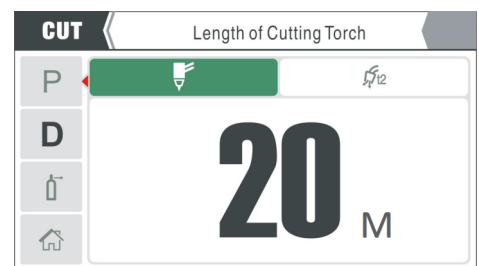

The second tab highlighted right is the parameter settings that allows you to select post gas time. When cutting finishes the air is required to stay on for a period of time to assist with the cooling the consumables and torch. Post flow time is adjustable between 10 ~ 60 seconds.

The factory setting is 15 seconds.

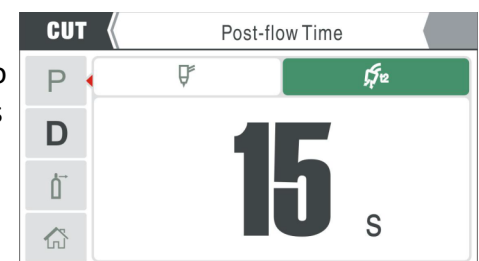

DESCRIPTION OF 'TFT-LCD' CONTROL PANEL

Display screen options

Gas Check Function

When not cutting in either 'Continuous Cut' or 'Mesh Cut' you can activate the gas to check your gas flow by selecting the gas check function, highlighted in green below.

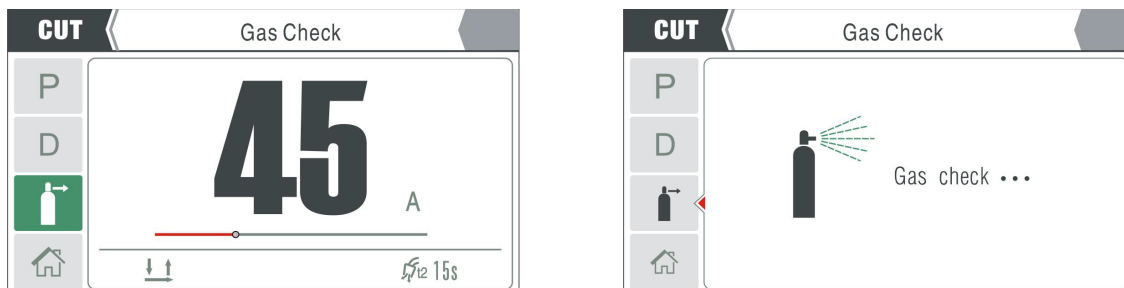

If the gas check symbol is shown, as above right shows, you now have air flowing through the plasma torch which indicates that the machine is now in 'Gas Check' mode.

Pressing the control dial again or waiting for 20s will stop the gas flow and exit gas check mode.

Settings

 From the home screen, rotate the control dial to the settings icon (shown left) and then press the control dial. You will then enter the settings screen, from here you can scroll to information such as system information, language choice, unit selection, factory reset, software versions and system configuration as shown below.

System information

From the settings screen, rotate the control dial to the 'Ver' tab and then press the control dial. You have now entered the machine's system information screen. The machine's rated output current, the machine's software and screen versions as well as serial number are all displayed here (as shown below).

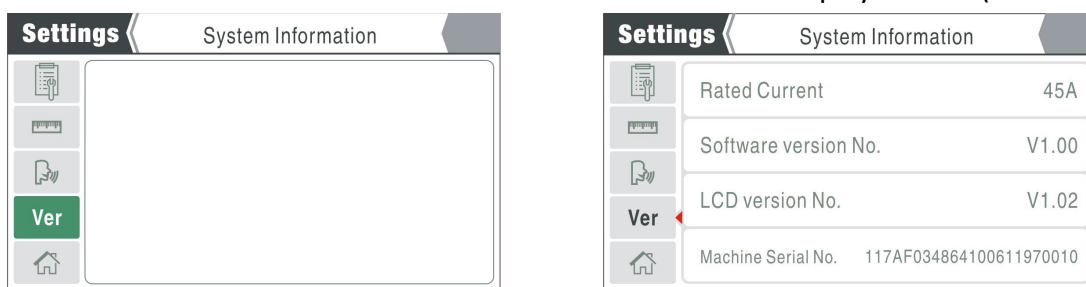

Language Selection

From the settings screen, rotate the control dial to the 'language' tab and then press the control dial. You have now entered the language option screen as shown below.

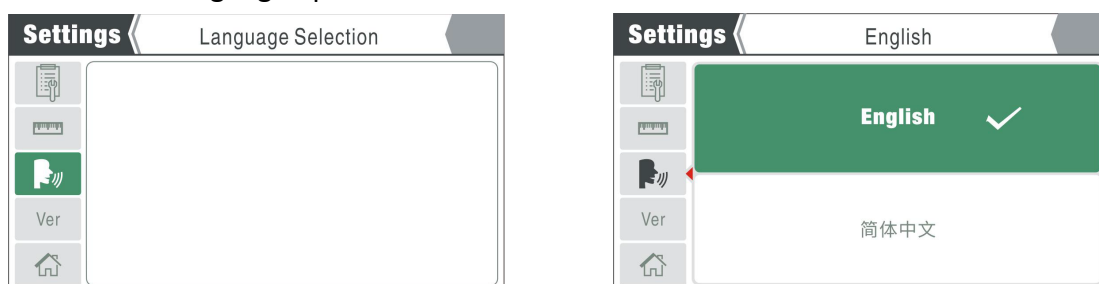

DESCRIPTION OF 'TFT-LCD' CONTROL PANEL

Display screen options

Language Selection (continued)

From the language screen, you can rotate the control dial to scroll through the installed language options and select your choice by pressing the control dial button.

Press the return button or home button to exit

Unit Configuration

From the settings screen, rotate the control dial to select the 'unit' tab  and then press the control dial, you have now entered the unit option screen as shown below.

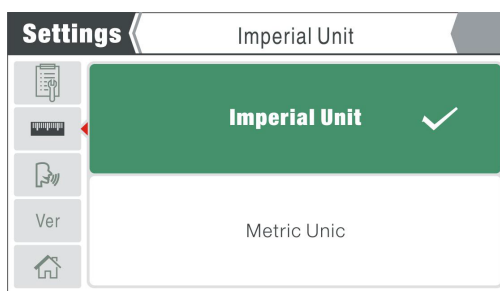
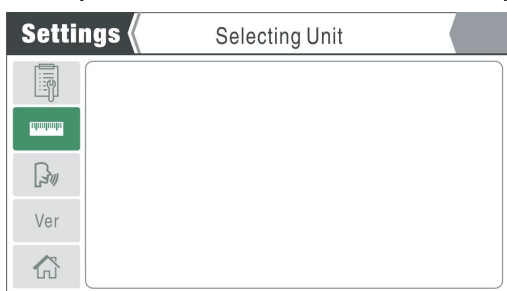

From here you can select either metric or imperial by pressing the control dial button.

Imperial is the factory setting.

Protection Status Alarm

If the machine encounters a fault or is not working correctly, an error code maybe displayed as shown right.

The example shown is error E60 which is an 'over temperature' error.

For a detailed list of error codes, please see page 39.



Configuration Settings (Engineers mode)

From the settings screen, rotate the control dial to the 'configuration' tab  and then press the control dial. You have now entered the engineers option screen as shown below.

From here you can access various options such as: stand by time, overvoltage protection, parameter and factory reset modes.

Standby Time

Standby time is a function that when there is no operator activity with the plasma machine, then after a pre-determined time (10 minutes as shown below) the machine will go into standby (sleep) mode.

From the configuration screen, rotate the control dial until the 'Stand by Time' option is highlighted and press the control dial. You have now entered the unit stand by time screen as shown below where you can adjust the stand by time between 0 to 15 minutes. (0 being off)

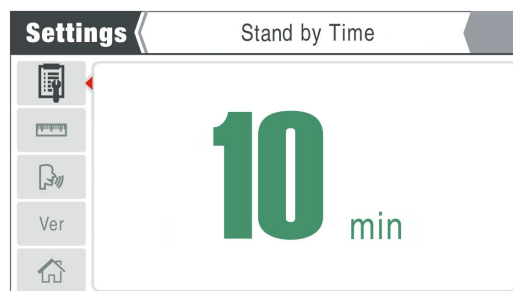
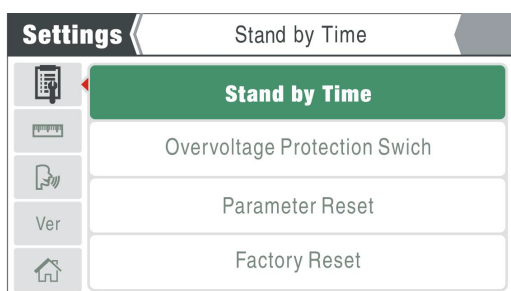

DESCRIPTION OF 'TFT-LCD' CONTROL PANEL

Display screen options

Overvoltage protection option

From the configuration screen, rotate the control dial until the 'Overvoltage Protection Switch' option is highlighted and press the control dial. You can now select either ON (open/enabled) or OFF (close/disabled) as shown below.

Please Note: Only technical personnel should disable overvoltage protection.

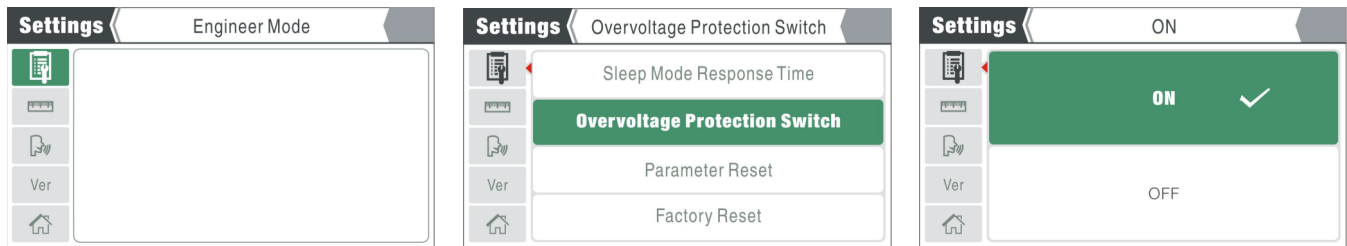

Parameter Reset:

This option allows the operator to reset parameter for all cutting parameters of the machine. On selecting the parameter reset option you can rotate the control dial to either accept or cancel the reset process, pressing the control dial to accept will then reset all saved parameters.

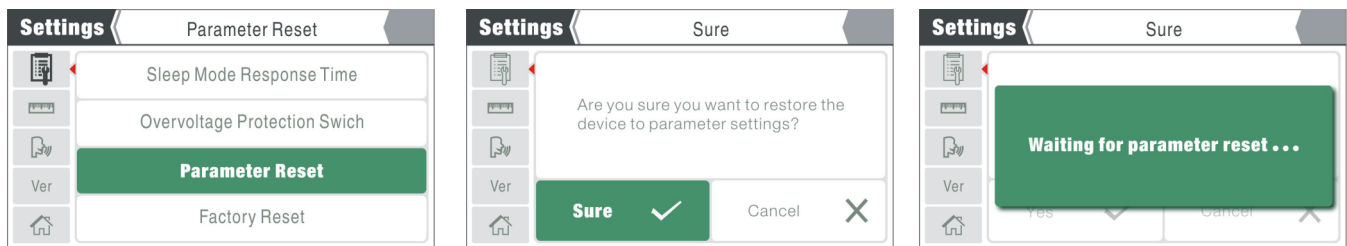

Factory Reset:

This option allows the operator to reset all parameters and back ground settings of the machine. On selecting the factory reset option you can rotate the control dial to either accept or cancel the reset process. Pressing the control dial to accept will then reset the machine to factory default settings.

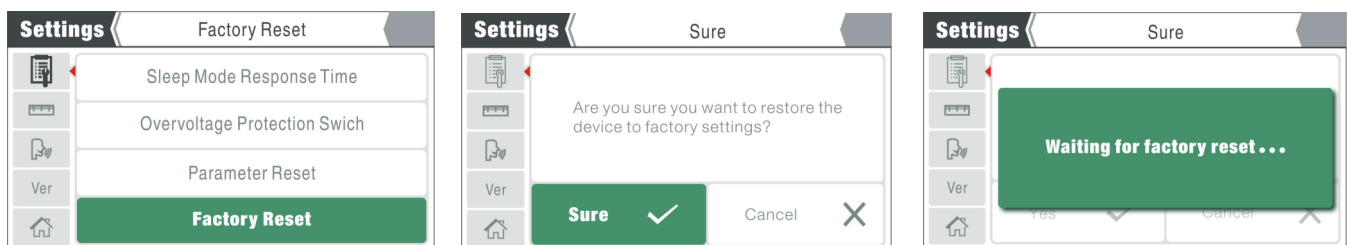

On completion of any of the above settings, once the required action is complete, press the back button or the home button to return to the main operator screen.

DESCRIPTION OF 'TFT-LCD' CONTROL PANEL

Display screen options

User manual

In the 'Home page', rotate the control dial to the 'user manual'  tab and then press the control dial. You have now opened the user manual option screen as shown below where you have easy access to some of the machines user instructions.

From here you can learn about the user interface control panel including the machine components and operation. The internal manual also covers the plasma torch, maintenance and troubleshooting of the plasma machine.

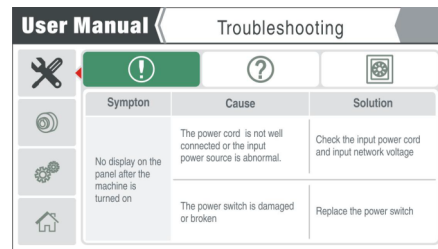
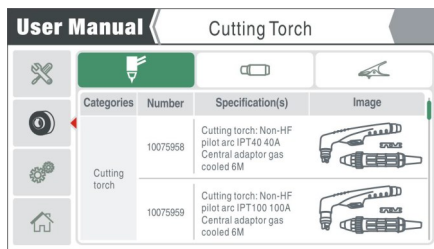
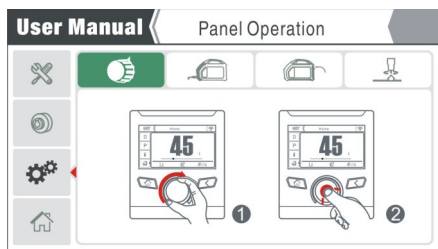

To exit the user manual option, press the back button or the home button to return to the main operator screen.

DESCRIPTION OF AIR COMPRESSOR EP-SC (Supplied with EP-45SC)

Overall view and technical details

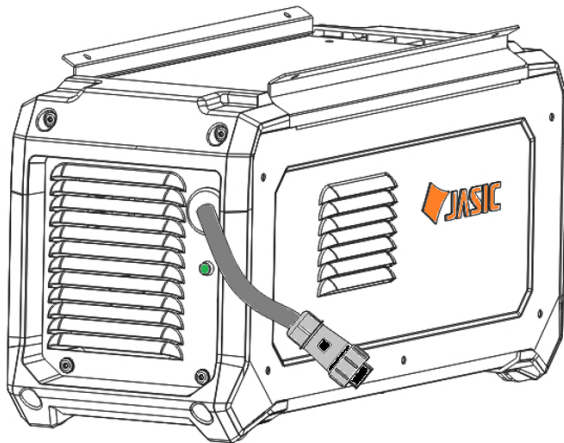

Parameter	Unit	EP-SC Jasic Air Compressor
Rated input (U1)	V/Hz	AC 95 ~ 265V 50/60Hz
Rated input current	A	3.7 +/-5%
Rated input power	W	780 +/-5%
Rated air pressure	MPa	0.25 +/-%
Max pressure	MPa	0.4
Rotation Speed	rpm	2800
Protection class	IP	IP23S
Insulation class	-	H
Size (with handle)	mm	463 x 187 x 236
Net weight	Kg	17.15
Overall weight	Kg	18.40

Front view Jasic EP-SC air compressor

1. Front panel with integrated cooling vents
2. Input power indicator light
3. Input power cable and 4 pin control plug which connects to the power source front panel matching 4 pin socket

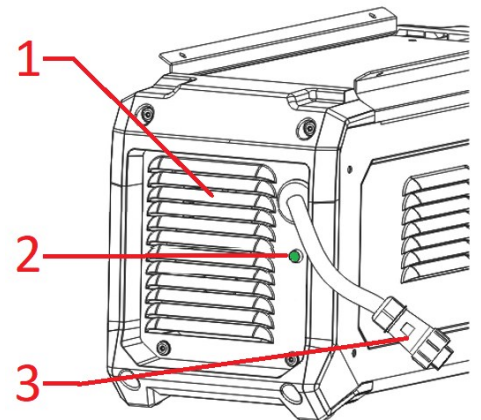

Rear view Jasic EP-SC air compressor

4. Intake air filter caps which lock in place the air filter elements (see page 42)
5. Compressed air outlet connection which connects the air hose to the power source regulator inlet (see page 28)

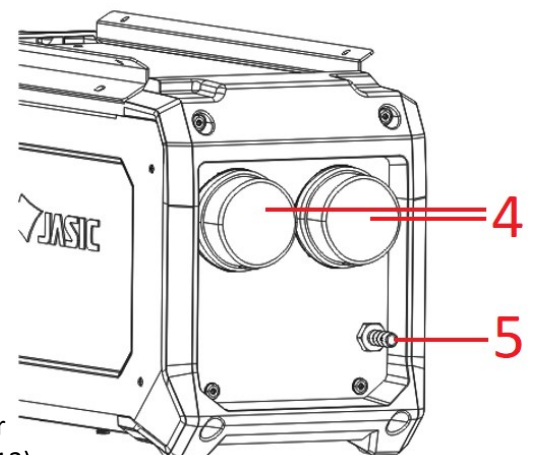

Please Note:

When using the EP-45SC via a portable transformer, please ensure that you use a suitably sized 115v transformer or the add-on compressor start up performance will be impacted (see technical specification page 13)

INSTALLATION

Installation

The owner/user are responsible for installing and using this plasma machine according to this operating manual.

Before installing this equipment, the owner/user shall make an assessment of potential hazards in the surrounding area.

Unpacking

Check the packaging for any signs of damage. Contact your supplier in the first instance if any item is missing or damaged.

Carefully remove the machine and retain the packaging or at least until the installation is complete.

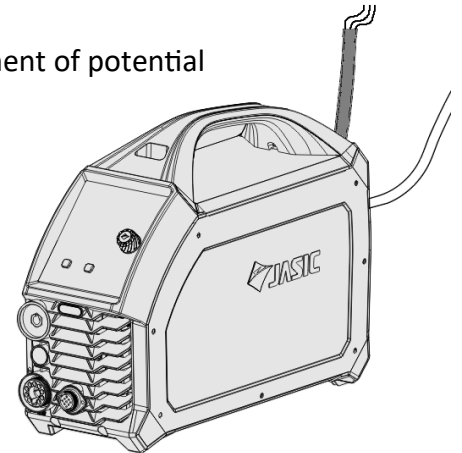

Lifting

The Jasic EP-45 range do have an integrated handle for hand lifting only. Please ensure the machine unit is lifted and transported safely and securely.

Location

The machine should be located in a suitable position and environment.

Care should be taken to avoid moisture, dust, steam, oil or corrosive gases.

Place on a secure level surface and ensure that there is adequate clearance around the machine to ensure natural airflow.

Do not use the system in rain or snow.

Position the plasma power supply near an appropriate power point ensuring you leave at least 30cm of space around the machine to allow for proper ventilation.

Always place the machine on a firm level surface before using ensuring it cannot tip over. Never use the machine on its side.

Most metals including stainless steel can give off toxic fume when welded or cut.

To protect the operator and others working in the area its important to have adequate ventilation in the work area to ensure air quality level meets all local and national standards.

Warning!



The following operation requires sufficient professional knowledge on electric aspects and comprehensive safety knowledge. All connections shall be made with the power supply turned off. Incorrect input voltage may damage the equipment.

Electric shock may cause death; after switching off the machine, there are still high voltages within the machine, so if removing the covers do not touch any of the live parts on the equipment for at least 10 minutes. Never connect the machine to the mains supply with the panels removed.

The electrical connection of this equipment shall be carried out by suitably qualified personnel and these shall be made with the power supply off. Incorrect voltage may damage the equipment.

Input power connection

Before connecting the machine you should ensure that the correct supply is available.

Details of the machine requirements can be found on the data plate of the machine or in the technical specification table shown on page 13 within this manual.

The equipment should be connected by a qualified competent person. Always ensure the equipment is correctly grounded.

INSTALLATION

Input Power Connection continued

Warning!

1. Test with multi-meter to ensure the input voltage value is within the specified input voltage range.
2. Ensure that the power switch of the welder is turned off.
3. Wire the input mains cable wires to the correct sized mains plug, ensuring that the live, neutral and earth (ground) wires are connected correctly.
4. Carry out an electrical test of the machine if required (i.e. PAT test)
5. Ensure that the mains supply fusing is correctly rated for the machine.
6. Connect the machine mains power plug firmly to the corresponding supply socket.

Please Note!

If the machine needs to be operated on long extension leads, then please use an extension lead where the cable has a larger cross-sectional area to reduce the voltage drop, please consult your electrician or electrical supplier for the recommended size.

Input air connection

- The Jasic EVO EP-45 and EP-45SC Plasma machines are only designed to be used with a reliable, consistent supply of clean, dry compressed air which is essential for correct operation. The EP-45SC version can utilize its own 'internal' compressed air supply system.
- Do not use with oxygen or any other gas.
- Ensure your compressor offers only dry compressed air and is capable of delivering the volume of air that is required to run your plasma cutting machine to specification. We recommend the minimum air supply requirements of 170 Ltr/min @ 5 Bar (75psi). The compressor or air cylinder air requirements are as follows:
 - ◆ Minimum air input: 5 Bar (75psi)
 - ◆ Maximum air input: 6 Bar (87psi)
 - ◆ Minimum air flow: 6CFM (170Ltr/min)
- It is recommended the compressed air supply should have an external filtration device installed in the line supplying the machine, including a water trap and filter
- Connect the compressed air with the supplied air hose and air fitting to the machine via the inlet connection on the rear panel (max 8 Bar).
- The air regulator for the EP-45 and EP-45SC units is mounted on the rear panel and is adjustable.
- Any water which has been collected by the air regulator will be drained by the auto drain system of the inbuilt air regulator.
- When using either a compressed air cylinder or a compressor, ensure it is equipped with a suitably fitted high pressure regulator capable of reducing the pressure to the required amount.

USER SETUP

Output connections

Work return cable

Insert the cable plug of the work return lead into the dinse socket on the front panel of the welding machine and tighten it clockwise.

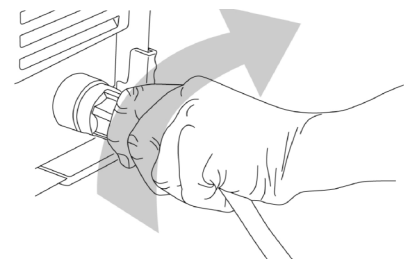
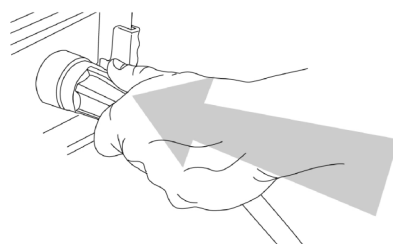

Check these power connections daily to ensure they have not become loose otherwise arcing may occur when used under load.

USER SET UP



Before starting any welding activity ensure that you have suitable eye protection and protective clothing. Also take the necessary steps to protect any personnel within the welding area.

Output connections

Plasma torch

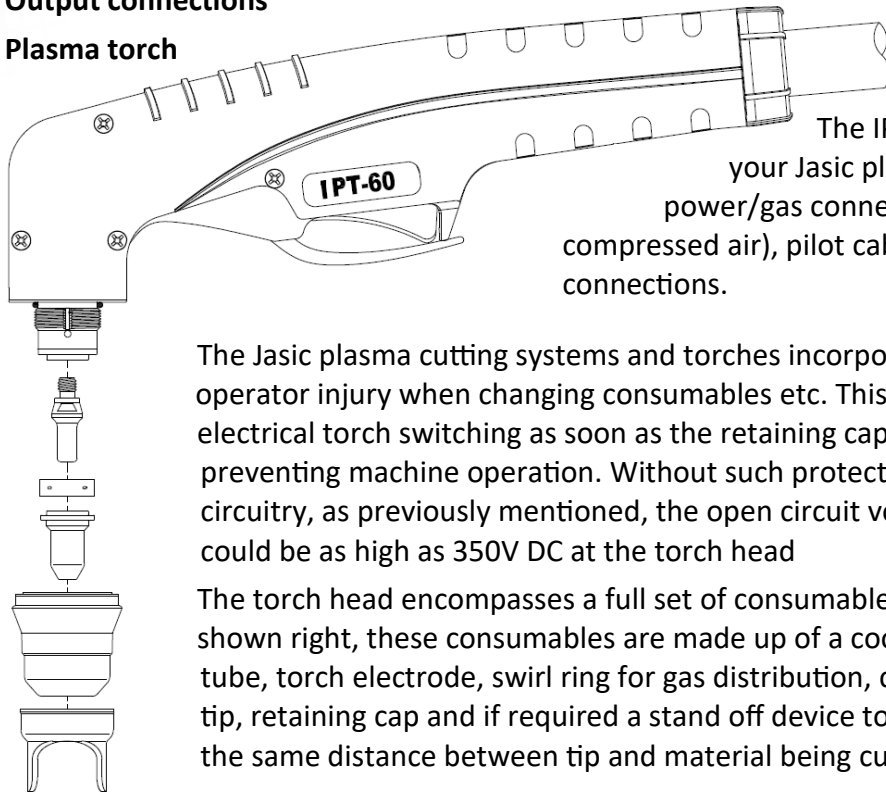

The IPT60 plasma torch supplied with your Jasic plasma machine has the 'euro style' power/gas connection (in this case the gas used is compressed air), pilot cable and the torch switch pin connections.

The Jasic plasma cutting systems and torches incorporate a safety circuit to prevent operator injury when changing consumables etc. This is a simple circuit that breaks the electrical torch switching as soon as the retaining cap is removed preventing machine operation. Without such protection circuitry, as previously mentioned, the open circuit voltage could be as high as 350V DC at the torch head

The torch head encompasses a full set of consumables as shown right, these consumables are made up of a cooling tube, torch electrode, swirl ring for gas distribution, cutting tip, retaining cap and if required a stand off device to ensure the same distance between tip and material being cut.



Fitting the supplied plasma torch

On the Jasic EVO range of plasma machines, the plasma torch fitting instructions (shown below) need to be observed.

- ⇒ Locate plasma torch plug into euro connector socket as shown in image 1
- ⇒ Push the torch as shown in image 2 and then rotate the locking nut clockwise until fully connected and tight as shown in image 3



Image 1



Image 2



Image 3

USER SET UP



Before starting any welding activity ensure that you have suitable eye protection and protective clothing. Also take the necessary steps to protect any personnel within the welding area.

Please note: The following should only be carried out by the authorised operator.

Air pressure setting

The external air pressure regulator is mounted on the machines rear panel and is only present and used when workshop compressed air is connected.

Checking and testing air quality should be carried out periodical as adjustment can often be required, this process is easily carried out following the instructions below:

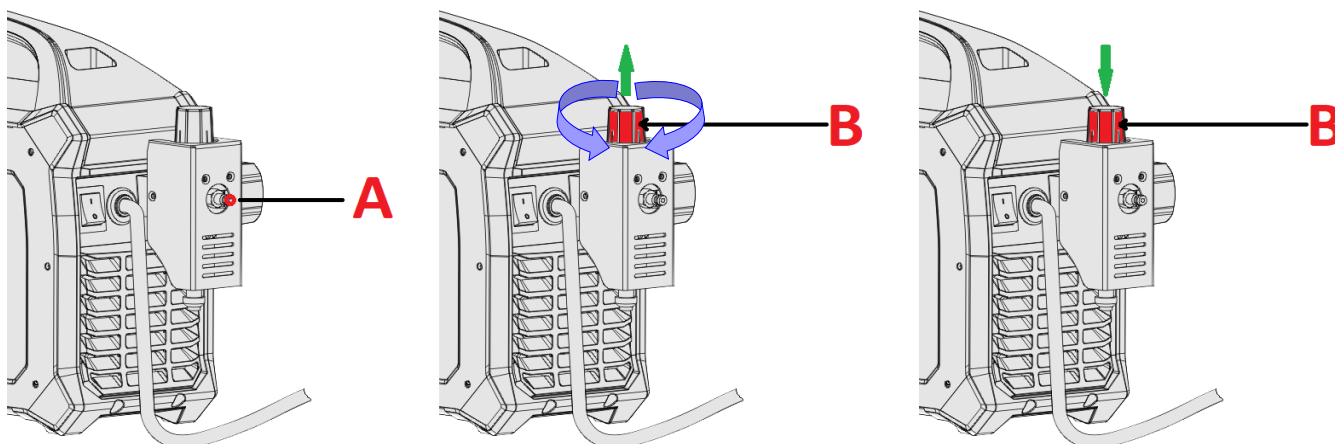

Image 1

Image 2

Image 3

1. Ensure the plasma torch is securely in place (see page 27).
2. Connect the workshop air supply to the machine via the air regulator inlet (A) mounted on the rear panel (image 1).
3. Connect the machine to the mains supply and switch the machine ON (located on the rear panel the machine (see pages 13 and 16)).
4. Depending on which control panel your machine has, activate the test air option which will then activate air purging to start the air flow through the machine and plasma torch (refer to pages 15 or 20 for further information).
5. Using your fingers, lift up the pressure control knob (B) of the pressure regulator to 'unlock' it shown in image 2.
6. Now (if required) adjust the air pressure by rotating the knob (B) in either clockwise direction to increase the air pressure setting or anticlockwise to reduce the pressure which will be noted on the pressure gauge.
7. When the correct air pressure is set on the regulator gauge, push down the adjusting knob (B) in image 3 to lock it.

Please Note:

- ◆ Any water which has been collected by the air regulator will be drained by the auto drain of the regulator when the airline is connected.
- ◆ Always ensure that your compressed air supply is clean and dry, this can be achieved by installing air filters and air driers as required.
- ◆ Due to condensation build up in supply pipes from the compressor, its good practice to always have an air filter and/or air drier mounted inline at the outlet (connection point) for the plasma machine.

OPERATION



Before starting any welding or cutting activity ensure that you have suitable eye protection and protective clothing.

Also take the necessary steps to protect any persons within the welding area.

Plasma cutting

Check that all connections have been made as required. Check the following before starting the machine.

- Check if the machine is reliably grounded according to the relevant local standards.
- Check that there are no bad contacts.
- Check if the mains power cable is connected to the correct input voltage and rated supply.
- Check if the plasma torch, connecting cables and gas hoses are in good condition and are not twisted.

Operation

1. Turn on the power switch to the 'ON' position via the back panel of the machine and the control panel will light up, the cooling fan will start to rotate and the machine is ready to operate normally.

Please Note: Some models are equipped with smart fan technology.

When the power supply is turned on for a period before welding or cutting the fan will automatically stop running. It will run automatically when cutting begins.

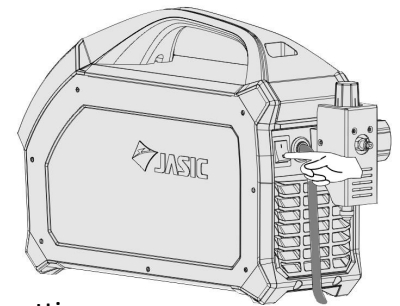

2. Set the cutting current according to the thickness of the material you are cutting.
3. Ensure that the cutting tip and consumables fitted matches the application and the cutting amperage set on the machine control panel display.
4. Select trigger mode required via the front control panel: 2T and 4T.
 - 2T continuous cutting:** When the main arc is extinguished due to lack of base material, the cutting machine automatically cuts off the output. You must release the torch trigger and press it again to re-establish the pilot arc and keep cutting.
 - 4T continuous cutting:** When the main arc is extinguished due to lack of base material, the cutting machine automatically transfers to pilot arc output, and the pilot arc can be re-established and cutting continued without releasing the torch trigger.
5. Select 'mesh cutting' mode if the material or application requires.
 - Mesh cutting:** When the main arc is extinguished due to missing workpieces, the cutting machine will automatically re-establish the pilot arc and maintains it for a certain period of time. When the pilot arc contacts the workpiece and ignites the main arc, cutting can continue. In mesh cutting mode, the machine will automatically be in 2T mode (4T is unavailable).
6. Check the air pressure by placing the purge/run switch into purge to set the correct pressure.
7. Press the air pressure switch again to put the machine into ready mode, when in air pressure check/test mode the corresponding LED will light up.
8. Depending on application and consumable setup, bring the copper nozzle of the plasma torch at a distance of about 2mm between the copper nozzle (tip) of the torch and the work piece and then press the torch trigger. For other modes of cutting/gouging, please see 'Modes of cutting' from page 30 and torch setup page 34.
9. After the arc has ignited, cutting starts and you can now start moving the torch at a regular speed along the material you are cutting.

Please note: The electrode and nozzle will wear out quicker if the operator holds the trigger when in pilot arc mode for too long prior to cutting. Always keep the time between piloting and cutting to a minimum.

OPERATION



Before starting any welding activity ensure that you have suitable eye protection and protective clothing. Also take the necessary steps to protect any personnel within the welding area.

Operation continued

Normal cutting mode

Normal cutting - this mode is the most commonly used for edge start or pierce cutting.

When edge cutting, hold the torch perpendicular to the edge of the material being cut with the cutting tip near (but not touching) the edge of the workpiece at the point where the cut is to start. Press and hold the trigger and once the pilot arc has initiated, slowly move the torch over the material until the cutting arc is established then 'cutting' movement can commence. Generally the direction of cutting is towards the user.

To stop cutting just release the torch trigger.

However if the plasma torch is either pulled away from the material or you come to the end of the material being cut and you run off the plate the plasma cutting arc will automatically stop. To re-initiate the plasma arc you would have to release the torch trigger to repress the trigger, so in the case of cutting grid or perforated material we have the following option that should be used.

Perforated cutting mode (Mesh cutting)

Perforated cutting - This setting is ideal if you are cutting mesh, grid or perforated type material (as image 1 shows below) where you have gaps between the material being cut.

When cutting in 'normal' mode the plasma arc will automatically 'cut out' if it can't find metal to complete the electric circuit, so switching the machine to perforated cutting mode will keep the plasma arc ON otherwise, you will have to keep releasing/pressing the trigger to restart the plasma arc over and over.

When in perforated cutting mode and when cutting in the travel direction as shown in image 2 below, the torch plasma arc circuit will switch between piloting mode and cutting mode automatically, depending if your torch is above the material or not.

Image 1 below shows an example of material which when cutting would be used in the 'mesh/perforated' setting mode.

Image 2 below helps to explain how the machine can cut perforated/mesh material and automatically switches between pilot and cutting mode without the operator having to release and then re-press the torch trigger multiple times.

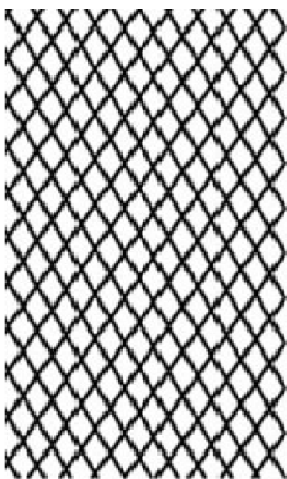

Mesh Material

Image 1

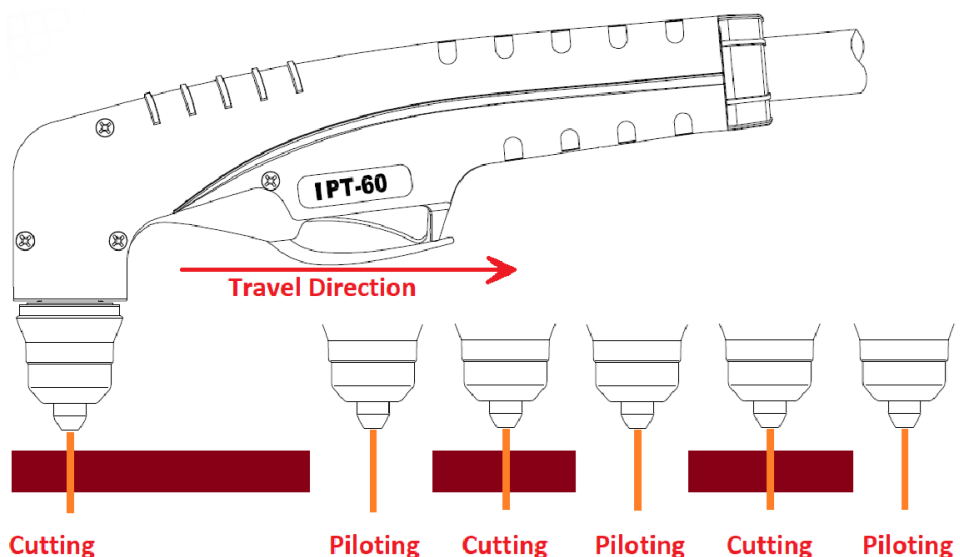

Image 2

OPERATION - MODES OF CUTTING



Before starting any welding activity ensure that you have suitable eye protection and protective clothing. Also take the necessary steps to protect any personnel within the welding area.

Modes of cutting

The following pages show various ways by using different consumable configurations that allows the operator to cut material with the plasma torch.

See page 34 for the full consumable selection options for the IPT-60 plasma torch.

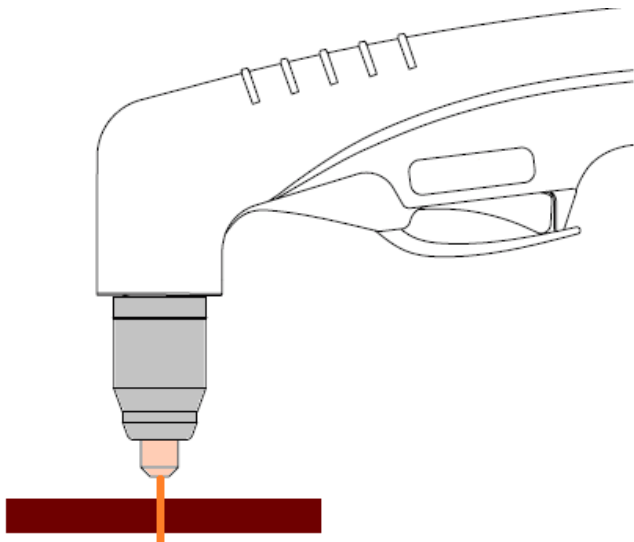

FREE HAND STAND-OFF CUTTING

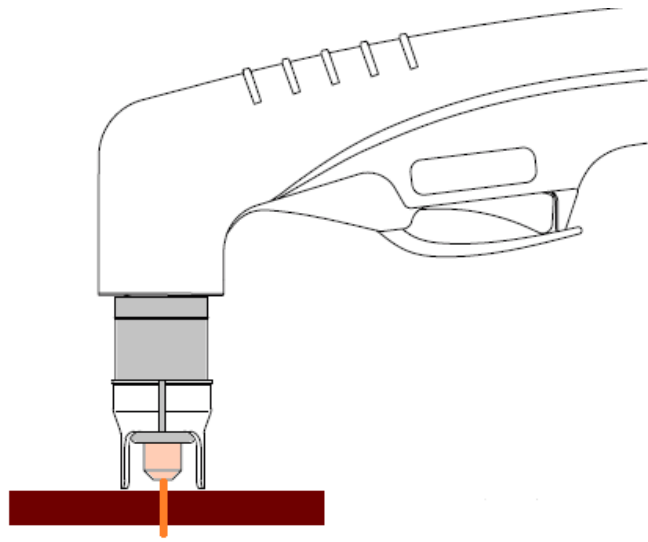

STAND-OFF GUIDE CUTTING

Stand-Off Cutting

The stand-off cutting technique is the process of holding the tip of the torch between 3 ~ 4mm from the workpiece to achieve the optimum cut.

Stand-off cutting requires a cutting tip that you need to ensure that the plasma machines output amperage is matched to the amperage with the tip.

Depending on the application, the operator may choose to hold the torch 'free hand' away from the plate or could choose to use a stand-off guide to help hold the torch away from the plate at a fixed height. Also available are roller guides and circle cutting guide kits which can be very helpful in creating the cuts you want.

To begin cutting you would place the torch above the work piece of about 3~4mm, and begin drawing the tip across the workpiece.

You should always start with the torch placed at the furthest point from you and then cut by pulling the torch towards you.

Make sure to keep the torch upright to the material being cut throughout the cutting process.

As you are cutting, ensure you maintain a smooth and consistent travel speed to make a clean and precise cut.

There are 3 main reasons why plasma machine operators prefer to use the stand-off technique rather than drag tip cutting

- ⇒ It allows for a smoother movement of the torch above the material being cut without any part of the torch touching the material.
- ⇒ You can comfortably stand the torch while making the contouring process or following a certain pattern.
- ⇒ Because the cutting tip is not touching the material, this helps to prevent any blowback of molten material.

OPERATION - MODES OF CUTTING



Before starting any welding activity ensure that you have suitable eye protection and protective clothing. Also take the necessary steps to protect any personnel within the welding area.

Modes of cutting

The images below show two different ways by using different consumable configurations that allows the operator to cut material with the plasma torch.

See page 34 for the full consumable selection options for the supplied plasma torch.

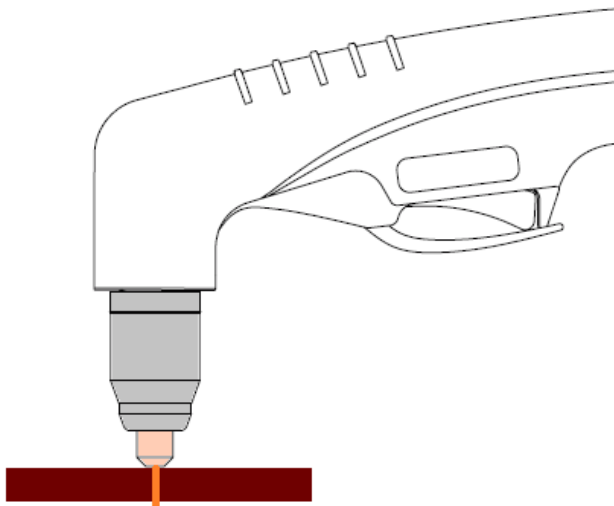

Drag Tip Cutting

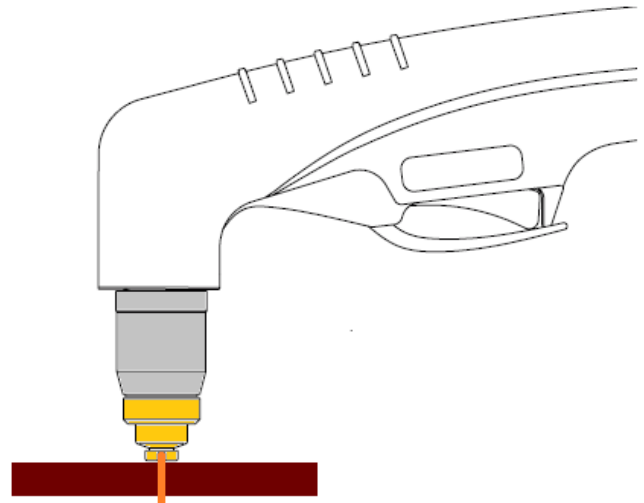

Drag Cap Cutting

Drag Tip Cutting

Drag tip cutting is the process of dragging the tip of the torch along the workpiece to cut the metal.

This is often the easiest way to cut while minimizing heat input but usually only on cutting currents of 40/45 amps and below. This technique works best when the material being cut is 5mm or less.

Drag tip cutting does require a 'drag' cutting tip and you need to ensure that the plasma machines output amperage is matched to the amperage with the cutting tip.

It can often be helpful to use a non-conductive straight edge to help maintain a straight cut.

Drag Shield Cap Cutting

The drag shield cap option allows the same technique to be used but having the cutting tip insulated (shielded) from the material being cut. Using a drag shield cap allows you to rest the torch (via the drag cap) on the workpiece while maintaining an optimal 2~3mm standoff without touching the cutting tip to the material for amperages of 40amps and above. (When cutting at above 40amps, touching the tip to the work material will adversely affect your cut quality and consumable life).

When you start to drag cut, you would place the tip/cap of the torch on the workpiece and begin dragging (moving) the torch across the workpiece. You should always start with the torch placed at the farthest point from you and then cut by pulling the torch towards you while making sure to keep the torch upright to the material being cut throughout the cutting process.

As you are drag cutting ensure you maintain a smooth and consistent travel speed to make a clean, precise cut.

The main benefits of drag cutting is:

- ⇒ Much easier for the operator because you don't need to maintain a distance between the cutting tip and the workpiece. You can simply drag the end of the plasma torch along a template or a straight edge. This process usually ensures a more accurate cut.
- ⇒ Drag cutting produces less spatter and blow back and improves the life of the front end torch parts.
- ⇒ Best cut quality for material of 5mm or less.

OPERATION - MODES OF CUTTING



Before starting any welding activity ensure that you have suitable eye protection and protective clothing. Also take the necessary steps to protect any personnel within the welding area.

Modes of cutting

Piercing

When not starting your cut from the material edge, most likely you will be piercing the material when starting the cut which is the process in which a quick hole is made in the work piece.

Piercing is often just a starting hole that will be used to make a 'circular' cut within the material.

You can use standard cutting tips for piercing although you must ensure the plasma machines output amperage matches the cutting tip amperage rating. The thickness of the material to be pierced will need to fall in the correct amperage range for the machine and cutting tip installed. If the material is slightly thicker than the machines piercing capacity, you can pre-drill a hole and treat your cut like an edge start cut.

There are two different techniques for piercing depending on the thickness of the work piece.

If the work piece is less than 2mm sheet metal, the torch can be held at a 90° (perpendicular) angle to the material being cut with the cutting tip or torch stand off touching or about 2mm away from the work piece (this can depend on which consumable configuration you have installed). Begin by establishing the pilot arc and as soon as the pilot arc/main cutting arc penetrates the work piece maintain your normal cutting height and the cutting process can then begin.

If the material being cut is thicker than 2mm the torch should be held at a 30 ~ 60° angle approximately 2 to 3mm above the work piece ensuring to direct the 'blown back' particles away from the torch tip, operator and any bystanders. Begin by establishing the pilot arc and when the pilot arc transfers, use a smooth, slow rolling motion to move the torch to a 90° (perpendicular) angle.

At this point, the pierce should have been created (if not hold the torch still until the cutting arc sparks exits the bottom of the work piece). Now the pierce has been made, the cutting process can begin.

Bevelling

Bevelling allows you to angle the edge of a flat plate or pipe to allow for deeper weld penetration. This process is normally used for materials that are 9mm or thicker.

You can utilize standard cutting tips for bevelling, but again, you need to ensure you utilize the correct plasma machine current matches the cutting tips used.

Ensure that the thickness of the material to be bevelled falls in the amperage range of the plasma machine and cutting tip that you will be using.

If bevelling by hand, a roller and/or angle guide can be helpful in maintaining the consistent bevel face and the desired angle which is usually determined by the weld joint design.



The industry standard angle ranges are generally from 15 ~ 45°. The cutting tip would normally be between 3 ~ 6mm from the work piece. Bevel type roller guide kits (as shown left and above) can also be very helpful in creating the required bevel cuts.



HAND TORCH CONSUMABLE BREAKDOWN



The Jasic Cut EP-45 & EP-45SC are supplied with the IPT60 plasma torch

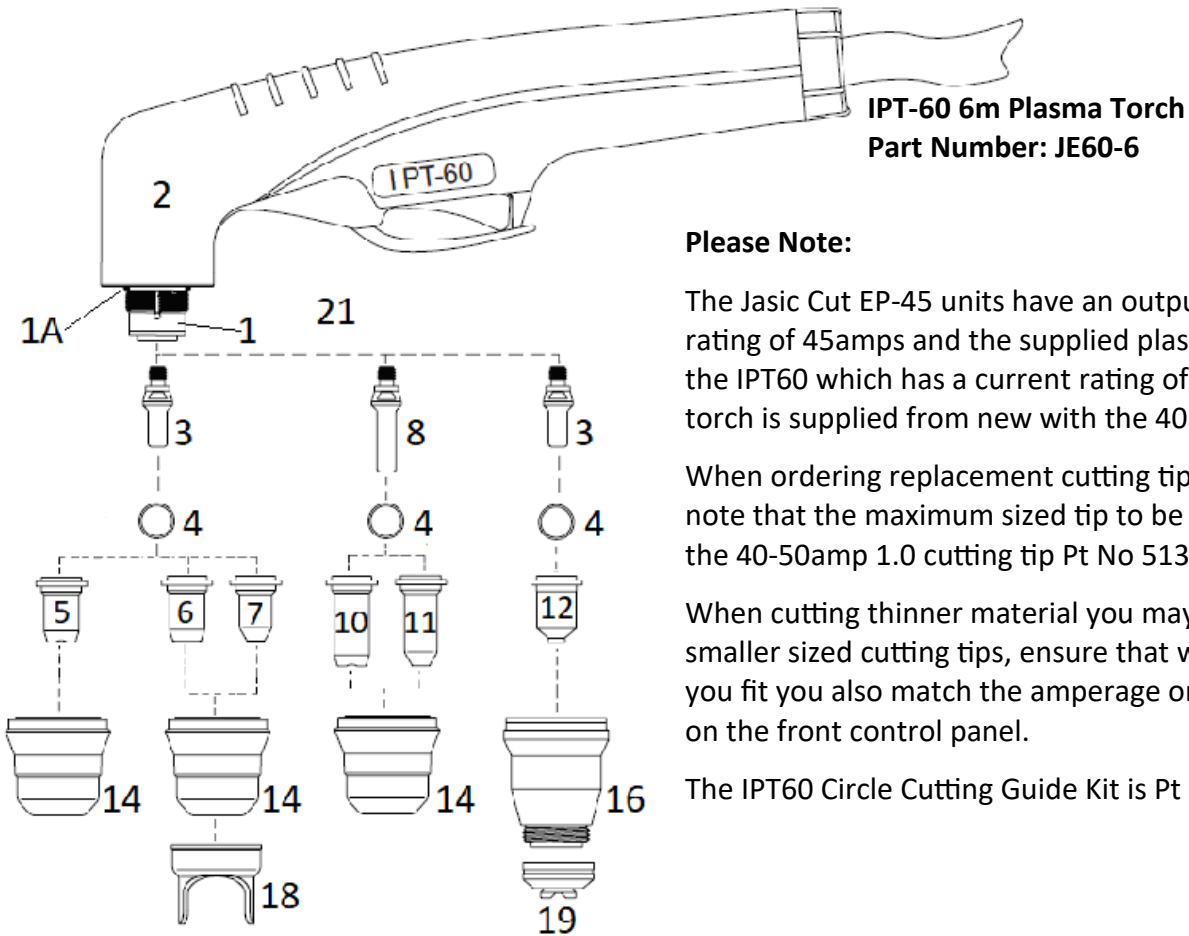

Please Note:

The Jasic Cut EP-45 units have an output current rating of 45amps and the supplied plasma torch is the IPT60 which has a current rating of 60amps, this torch is supplied from new with the 40amp tip fitted.

When ordering replacement cutting tips please take note that the maximum sized tip to be used would be the 40-50amp 1.0 cutting tip Pt No 51313P.10.

When cutting thinner material you may choose to fit smaller sized cutting tips, ensure that whichever tip you fit you also match the amperage on the amp dial on the front control panel.

The IPT60 Circle Cutting Guide Kit is Pt No 51866

Item No	Part Number	Description	Pack Qty
1	TBC	PT60 Torch Head	1
1A	5162060	Torch head 'O' Ring	1
2	TBC	Handle c/w Switch	1
3	52582	Electrode - Back Striking	5
4	60028	Gas Distributor	1
5	51312P.09	Contact Cutting Tip (0.9) 30-40A Back Striking	10
6	51313P.10	Flat Cutting Tip (1.0) 40-50A Back Striking	10
7	51318.06	Contact Cutting Tip (0.65) 10-20A Back Striking	10
7	51318.08	Contact Cutting Tip (0.8) 20-30A Back Striking	10
7	51318.09	Contact Cutting Tip (0.9) 30-40A Back Striking	10
8	52583	Extended Electrode Back Striking	10
10	51314.09	Extended Tip Contact (0.9) 30-40A Back Striking	10
11	51318L.06	Extended Tip Contact (0.65) 10-20A Back Striking	10
11	51318L.08	Extended Tip Contact (0.8) 20-30A Back Striking	10
12	51318C.09	Shielded Cutting Tip (0.9) 30-40A Back Striking	10
12	51318C.10	Shielded Cutting Tip (1.0) 40-50A Back Striking	10
14	60389	Retaining Cap	1
16	60389C	Shield Cup Body	1
18	60432	Double Pointed Spacer (for items 6 & 7 only)	1
19	60485	Shield Cap, Hand	1
21	09600.63	Wrench for Electrode	1

Please Note:

Configuration above only to be used on the Jasic Cut EP-45 and EP-45SC Plasma Machine

GENERAL CUTTING INFORMATION



Before starting any welding or cutting activity ensure that you have suitable eye protection and protective clothing. Also take the necessary steps to protect any persons within the welding area.

Notes for cutting operation

1. Do not touch the hot work piece with bare hands to avoid burning.
2. It is recommended not to ignite the arc in the air if not necessary, for it will shorten the lifespan of the electrode and nozzle of the torch.
3. It is recommended to initiate the cutting from the edge of the workpiece unless penetration is needed.
4. Ensure spatter comes from the bottom of work piece while cutting. If spatter comes upwards from the top of work piece, it generally indicates that the work piece has not been fully cut through. This could be due to a number of factors including, not enough cutting current, wrong consumable configuration, low air pressure/air flow or the cutting torch is moved too quickly.
5. For cutting a round work piece or to meet precise cutting requirement, a stencil board or other tools are needed.
6. It is recommended to pull the cutting torch while cutting.
7. Keep the nozzle of the cutting torch upright over the work piece and check if the arc is moving with the cutting line. Do not bend the cable too much, step on or press upon the cable to avoid restricting the air flow. The cutting torch may be burned if the air flow is too low. Keep the cutting cable away from sharp edges.
8. When the work piece is nearly cut off, slow down the cutting speed and release the torch trigger to stop cutting.
9. Check the torch consumables frequently to prolong the life.
10. Always ensure the correct consumables are fitted in the torch. Incorrect items may cause damage to the torch or machine.
11. It is recommended that a torch of maximum length of 6 metres is used. If the torch cable is too long, the performance of this cutting machine such as arc ignition will possibly be affected due to the fact that the inner resistance of the cable will reduce the output voltage.

Please Note:

- * Your air supply must be free of moisture, water, oil or any other contaminants. Excessive water or oil may cause double arcing, excessive electrode/tip wear or even torch head failure. Any contaminants will also cause poor cut quality.
- * When starting the arc, ensure you keep the pilot arc time to a minimum to avoid excessive wear on the cutting tip.
- * Do not overtighten the electrode when fitting a new set of consumables. Over tightening may cause damage to the head thread, the tip not to seat correctly
- * Only use the supplied or recommended 'O' ring lubricant or grease for your plasma torch head, using the wrong lubricant which cannot withstand high temperatures could cause damage to the plasma torch head.

CUT QUALITY

The plasma process cuts by melting the material and therefore a characteristic feature is the greater degree of melting towards the top of the metal resulting in poor edge squareness, top edge rounding or a bevel on the cut edge.

Cut quality can often depend on setup and your application parameters with torch height, cutting speeds, compressed air pressures along with the users abilities to maintain these during the cutting process.

To help understand cut quality, it is best that the characteristics of the finished cut are looked at in close detail, the image adjacent will help explain this.

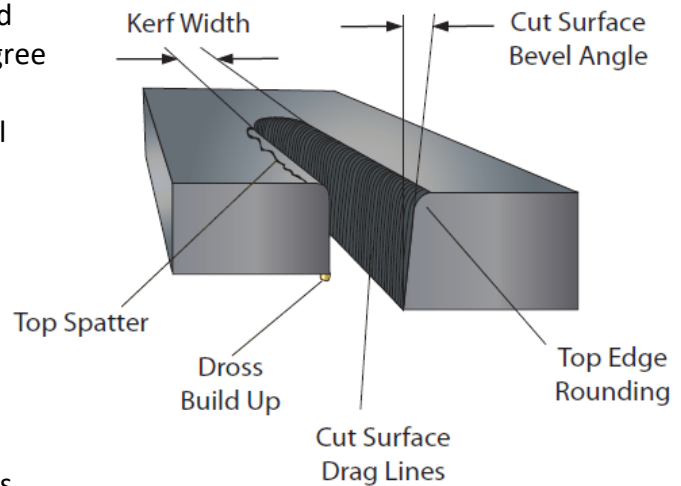

Cutting or torch angle

Generally when cutting with a plasma torch, the torch should be held perpendicular to the piece being cut.

Stand off distance

The distance between the torch tip and the work piece during the cutting process will have an effect on the bevel angles. The greater the distance, the greater the bevel angle will be. Typically, smaller hand cutting systems (usually 40 amps and under) are designed to drag the tip on the plate.

For higher amperage hand cutting systems, use of a drag shield cup, a standoff guide or a cutting guide will help keep a consistent tip to work distance for best results.

Kerf width

While plasma cutting a void is left behind which is called the kerf in the material being cut.

Bevel angle

In an ideal cut, the bevel angle or angle of the cut surface would be perfectly square.

The plasma cutting process does result in a slight angle which is called a bevel angle, on both the cut and scrap side of the work piece. This is why direction of cut is important. When the plasma gas flows, it has a swirling action as it leaves the cutting tip's orifice. This swirl is generally in a clockwise direction which results in one side of the material being cut being squarer than the other. This means it is very important to consider the travel direction in relation to the piece being cut.

In the image adjacent, a circle shaped object is being cut.

The inside cut (A) is done in the anti-clockwise direction and the outside cut (B) is done in a clockwise direction.

So remember, if you are making a circular cut and plan to keep the inside round piece as your finished work, move in a clockwise direction. If you plan to keep the piece from which the circle was cut from then move in an anti-clockwise direction.

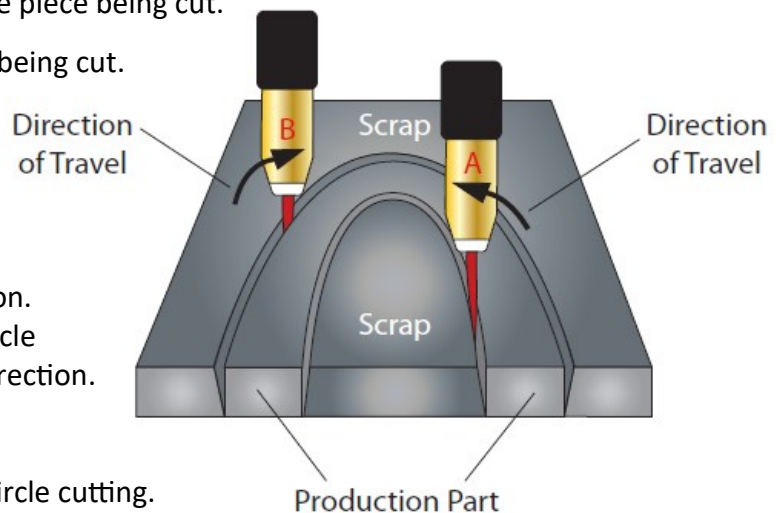

The Jasic EVO range of plasma machines offer optional circle cutting guide kits to assist with circle cutting.

CUT QUALITY

Dross

The formation of dross on the bottom of the plate can be caused when cutting parameters such as speed, amperage, arc voltage, gas pressure/flow and type of gas are not correct for the metal type and thickness being cut.

Most commonly, incorrect cutting speeds are to blame for excessive dross. High cutting speeds can result in high speed dross that can be very hard to remove without grinding. Low speed dross can be easily removed with a brush or chip hammer.

Top edge rounding

This is when the top edge of the cut face has eroded away and is not square which is created from the plasma cutting process. It is generally caused when cutting with excessive current or standoff distance. This can be a common occurrence when cutting thick materials.

TYPICAL CUTTING SPEEDS

Cutting speeds can vary according to power source output, cutting table quality, material thickness along with material type being cut as well as the operators skill set.

Speeds shown below are offered as a guide only for our Jasic hand cutting systems using compressed air, cutting mild steel material with the stated output currents ensuring that the cutting tip fitted matches the stated amperages.

Material Thickness	Amperage	Speed mm/m	Air Pressure
1mm	40	5000 - 6000	5 bar / 73psi
	60	6200 - 7000	5 bar / 73psi
	80	7200 - 8000	5 bar / 73psi
3mm	40	1800 - 2600	5 bar / 73psi
	60	3200 - 4200	5 bar / 73psi
	80	3800 - 4600	5 bar / 73psi
6mm	40	800 - 1100	5 bar / 73psi
	60	1200 - 2000	5 bar / 73psi
	80	1800 - 2500	5 bar / 73psi
12mm	40	200 - 300	5 bar / 73psi
	60	400 - 650	5 bar / 73psi
	80	650 - 820	5 bar / 73psi
15mm	60	400 - 500	5 bar / 73psi
	80	450 - 540	5 bar / 73psi
	100	750 - 880	5 bar / 73psi
20mm	60	280 - 340	5 bar / 73psi
	80	380 - 450	5 bar / 73psi
	100	400 - 480	5 bar / 73psi
	120	650 - 750	5 bar / 73psi
25mm	80	180 - 210	5 bar / 73psi
	100	200 - 240	5 bar / 73psi
	120	300 - 380	5 bar / 73psi
	160	400 - 480	5 bar / 73psi
30mm	160	320 - 400	5 bar / 73psi
45mm	160	230 - 350	5 bar / 73psi

Note: The above chart is a guide as many factors can distort cutting chart figures when hand cutting.

TROUBLESHOOTING



The following operation requires sufficient professional knowledge on electric aspects and comprehensive safety knowledge. Make sure the input cable of the machine is disconnected from the electricity supply and wait for 5 minutes before removing the machine covers.

Before any welding and cutting machines are dispatched from the factory, they have already been checked thoroughly. The machine should not be tampered with or altered. Maintenance must be carried out carefully. If any wire becomes loose or is misplaced, it may be potentially dangerous to the user!

There are dangerous voltages present within this plasma power supply unit. Only professionally trained maintenance personnel should repair the machine!

Ensure the power is disconnected before working on the machine. Always wait 5 minutes after power switch off before removing the panels.

Description of fault	Possible cause
Mains power switch is on, although the power indicator doesn't light up.	Check input power that it is turned on. Check the input power fuse. Check the input cable plug and connections. Check the ON/OFF switch for function and continuity.
Primary power switch is on, but the cooling fan does not work.	Check fan is not being blocked by debris. Check fan for functionality. Check fan supply.
No air flow at torch when either torch trigger is pressed or air purge switch is activated.	Check the compressor. Check all the input air connections and fittings. Internal connection is disconnected or loose. Check the purge switch for functionality.
Overheat error code is lit.	Machine operated outside duty cycle, allow the machine to cool and the unit will reset automatically. Fan not working - check for obstruction blocking the fan.
Nothing happens when plasma torch switch is closed	Check and test the plasma torch and leads (switch circuit
Pilot arc does not initiate when the torch switch is activated.	Gas pressure too low to the machine.
The pilot arc extinguishes soon after igniting	Check and replace the torch consumables. Check and adjust the air pressure. Check and if required drain any water build up in the filter cup of the regulator on the rear panel.
Pilot arc is ON but the cutting arc will not establish	Work cable not connected to work piece or damaged/broken. Check and replace the torch consumables.

TROUBLESHOOTING - ERROR CODES



The following operation requires sufficient professional knowledge on electric aspects and comprehensive safety knowledge. Make sure the input cable of the machine is disconnected from the electricity supply and wait for 5 minutes before removing the machine covers.

The control display is also used for providing error messages to the user, if an error message is displayed, the power source may only function to a limited capacity and the cause of the error should be checked as soon as possible.

The below is a list of error codes for the Jasic EVO EP-45 and EP-45SC plasma cutting machines.

Error Code	Code Description	Possible Cause	Check
E10	Overcurrent protection	The output is at maximum capacity current of machine	Turn the machine off and back on again. If overcurrent protection alarm is still active, contact an approved technician.
E31	Undervoltage protection	The input mains voltage is too low	Turn the machine off and back on again. If the alarm continues, check the input voltage for being remains too low. If the input voltage is within specification and the alarm persists, contact an approved technician.
E32	Overvoltage protection	The input mains voltage is too high	Turn the machine off and back on again. If the alarm continues, check the input voltage for being remains too high. If the input voltage is within specification and the alarm persists, contact an approved technician.
E60	Overheating	An over temperature signal received from the output rectifier circuit	Do not turn off the machine, wait for a while and after the thermal error goes off then you can continue cutting. While error code is ON, machine cannot cut. Ensure cooling fans are operational. Decrease duty cycle welding activity.
E61	Overheating	An over temperature signal received from the Inverter IGBT circuit	Do not turn off the machine, wait for a while and after the thermal error goes off then you can continue cutting. While error code is ON, machine cannot cut. Ensure cooling fans are operational. Decrease duty cycle welding activity.
E62	Overheating	Over temperature signal received from the PFC IGBT circuit	Do not turn off the machine, wait for a while and after the thermal error goes off then you can continue cutting. While error code is ON, machine cannot cut. Ensure cooling fans are operational. Decrease duty cycle welding activity.

TROUBLESHOOTING - PLASMA CUTTING PROBLEMS

The proper installation, application and operation of plasma arc cutting equipment can save many man hours and reduce costs which will give you the promised cut quality and longer consumable parts life.

Cut quality issues or poor consumable life are generally the most experienced problems seen with plasma cutting systems and more often than not are caused by the same thing, for example, low or too high air pressure, low air flow, water or oil in the supply airline will all give you poor cut quality and premature consumable wear. It's often difficult to diagnose cutting issues without understanding the machines use and setup and there are various questions that need to be asked to be able to give the best advice.

Below is listed a few pointers to help you on your way to obtaining consistently good cut quality:

- Ensure your mains power supply is suited to the plasma cutting machines specifications.
- Ensure the supplied gases or air supply is in keeping with the requirements of the plasma machine.
- Ensure your plasma machines amperage setting matches the amperage of the cutting tips.
- Clean and service the plasma machine and torch regularly, it is important that the operator watch the torch for signs of contamination or worn consumables being used.

Problem	Possible cause	Suggested action
Excessive use of consumables (short life time of consumables)	Low air pressure or low air flow (or too high)	Check for low air pressure to the plasma machine (low flow can be caused by a long air hose with a small internal diameter or leaks). Ensure your compressor is set to deliver the correct CFM as detailed in the plasma owner's manual and can keep this level maintained during your cutting operation (consider other equipment being used on the same airline).
	Contaminated gas or excessive moisture in the air supply	Use suitable airline filters or air dryers and service the devices as required as per the user manual. If using a compressor, ensure the receiver is drained regularly.
	Drag cutting at high amperages	Refer to the torch spare parts of this manual for the correct use of cutting tips and their amperage ratings.
	Dragging the cutting tip against a metallic straight edge	Ensure you use a non-metallic straight edge to guide the torch along.
	Excessive piloting	Keeping the pilot arc maintained will erode the consumables much faster than when cutting, keep piloting to a minimum.
Poor cut quality	Improper travel speed	Check the cutting guide chart (page 37) for the correct settings for the material being cut.
	Cutting amps not correct	
	Stand-off height not correct	
	Using incorrect torch consumables	Refer to the plasma spare parts breakdown on from page 34 of this user manual for the correct consumable configuration for the application.
	Worn consumables	Check and replace as necessary.
	Plasma not delivering enough output current	Have a technician check the output current of the plasma to ensure it is meeting demand.
	Incorrect air pressure or air flow to the machine	Check machines air demand specifications, refer to page 13 within this user manual to ensure the air supply meets the minimum requirements.

MAINTENANCE



The following operation requires sufficient professional knowledge on electric aspects and comprehensive safety knowledge. Make sure the input cable of the machine is disconnected from the electricity supply and wait for 5 minutes before removing the machine covers.

In order to guarantee that your cutting and welding machine works efficiently and in safety, it must be maintained regularly. Operators should understand the maintenance methods and means of cutting and welding machine operation.

This guide should enable customers to carry out simple examination and safeguarding by oneself, try to reduce the fault rate and repair times of the welding and cutting equipment, so as to lengthen the service life of your plasma machine.

Period	Maintenance item
Daily examination	<p>Check the condition of the machine, mains cables, welding cables and connections.</p> <p>Check for any warnings LEDs and machine operation.</p> <p>Check the torch consumable condition and replace if worn.</p> <p>Check the compressor air supply and adjust as required.</p>
Monthly examination	<p>Disconnect from the mains supply and wait for at least 5 minutes before removing the cover.</p> <p>Check internal connections and tighten if required.</p> <p>Clean the inside of the machine with a soft brush and vacuum cleaner.</p> <p>Take care not to remove any cables or cause damage to components.</p> <p>Ensure that ventilation grills are clear.</p> <p>Check inline air filters.</p> <p>Check compressor air inlet filters</p> <p>Carefully replace the covers and test the unit.</p> <p>This work should be carried out by a suitably qualified competent person.</p>
Yearly examination	<p>Carry out an annual service to include safety check in accordance with the manufacturers standard (EN 60974-1).</p> <p>This work should be carried out by a suitably qualified competent person.</p>

Please note:

Do not use compressed air to blow the dirt/dust out of the power supply or compressor unit.

- Your air supply must be free of moisture, water, oil or any other contaminants. Excessive water or oil may cause double arcing, excessive electrode/tip wear or even torch head failure. Any contaminants will also cause poor cut quality and shorter consumable life.
- When starting the pilot arc, ensure you keep the pilot arc time to a minimum to avoid excessive wear on the cutting tip.
- Do not overtighten the electrode when fitting a new set of consumables. Over tightening may cause damage to the head thread, the tip not to seat correctly
- Only use the supplied or recommended 'O' ring lubricant or grease for your plasma torch head, using the wrong lubricant which cannot withstand high temperatures could cause damage to the plasma torch head.

MAINTENANCE



The following operation requires sufficient professional knowledge on electric aspects and comprehensive safety knowledge. Make sure the input cable of the machine is disconnected from the electricity supply and wait for 5 minutes before removing the machine covers.

Maintenance

Filter element replacement

Regular replacement of the air filter is beneficial to increase the service life of the air compressor unit.

In normal working conditions, it is recommended to replace the filter element as per the following steps every 1000 hours or 12 months of the air compressor running.

1. Turn the rear panel air filter anticlockwise to open the outer cover.
2. Replace the internal filter element.
3. Install and restore the outer cover.

Please Note:

Disconnect from the mains supply and wait for at least 2 minutes before removing the air filter covers as to avoid injury to maintenance personnel or damage to the machine.

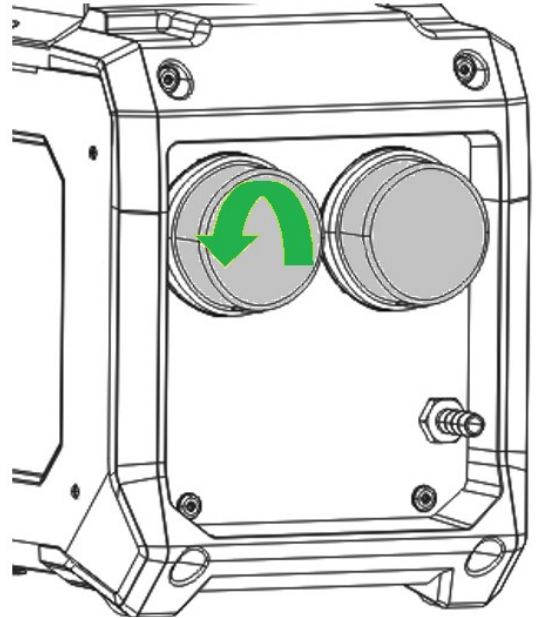

OPTIONS AND ACCESSORIES

Part Number	Description
JE60-6	6m Plasma Torch
EC-2-03LD	Work Return Lead and Clamp 3m
CP3550	Cable Plug 35-50mm
JH-HDX	Jasic HD True Colour Auto Darkening Welding Helmet
TFT-EP-45P	TFT-LCD 'Advanced' Control Panel Option
51866	Circle Cutting Guide Kit
EP-SC	Compressor unit

WEEE disposal

The equipment is manufactured with materials which do not contain any toxic or poisonous materials dangerous to the operator.

When the equipment is scrapped, it should be dismantled separating components according to the type of materials.

Do not dispose of the equipment with normal waste. The European Directive 2002/96/EC and United Kingdom's Directive The Waste Electrical and Electronic Equipment (WEEE) regulations 2013 states that electrical equipment that has reached its end of life must be collected separately and returned to an environmentally compatible recycling facility.

Jasic has a relevant recycling system which is compliant and registered in the UK with the environment agency. Our registration reference is WEEMM3813AA.

In order to comply with WEEE regulations outside the UK you should contact your supplier.

RoHS Compliance Declaration

We herewith confirm, that the above mentioned product does not contain any of the restricted substances as listed in EU Directive 2011/65/EU and the UK directive ROHS Regulations 2012 in concentrations above the limits as specified therein.

Disclaimer:

Please note that this confirmation is given to the best of our present knowledge and belief.

Nothing herein represents and/or may be interpreted as warranty within the meaning of the applicable warranty law.

UKCA Declaration of Conformity



UK DECLARATION OF CONFORMITY

The manufacturer or its legal representative Wilkinson Star Limited declares that the equipment listed described below is designed and produced according to the following UK directives:

Electrical equipment (Safety) regulations 2016	2016 No 1101
Electromagnetic compatibility regulations 2016	2016 No 1091
The restriction of the use of certain hazardous substances in electrical and electronic equipment regulations 2012	2012 No 3052
Requirements for welding equipment pursuant to the eco-design for energy related products and	UK SI 2021/745

And inspected in compliance with the following harmonised standards

- BS EN 60974-1:2018 + A1:2019
- BS EN 60974-10:2014 + A1:2015
- BS EN 62822-1:2018

Any alteration or change to these machines by any unauthorised person makes this declaration invalid

WILKINSON STAR MODEL

- EP-45
- EP-45SC

JASIC MODEL

- Cut 45 PFC L2S42
- Cut 45 PFC SC L2S421

Authorised Representative

Wilkinson Star Limited
Shield Drive, Wardley Industrial Estate
Worsley, Salford M28 2WD
Tel +44 161 793 8127

Signature

Dr John A Wilkinson OBE

Position

Date

Company stamp



Manufacturer

Shenzhen Jasic Technology Co Ltd
No3 Qinglan, 1st Road
Pingshan District
Shenzhen, China

Signature

Shenzhen Jasic Technology Co Ltd

Position

Date

Company Stamp

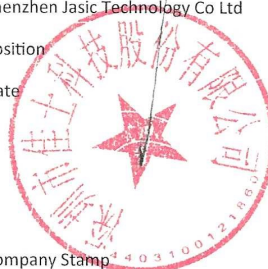

Handwritten signature and date: 29/1/2021



EC DECLARATION OF CONFORMITY



EU DECLARATION OF CONFORMITY

The manufacturer or its legal representative Wilkinson Star Limited declares that the equipment listed described below is designed and produced according to the following EU directives:

Low voltage directive (LVD)	2014/35/EU
Electromagnetic compatibility directive (EMC)	2014/30/EU
RoHS2	2011/65/EU
Annex 11 of RoHS2	2015/863
Eco design requirements for welding equipment pursuant 2009/125/EC	2019/1784

And inspected in compliance with the following harmonised standards

- EN 60974-1:2018 + A1:2019
- EN 60974-10:2014 + A1:2015
- EN 62822-1:2018

Any alteration or change to these machines by any unauthorised person makes this declaration invalid

WILKINSON STAR MODEL
EP-45
EP-45SC

JASIC MODEL
Cut 45 PFC L2S42
Cut 45 PFC SC L2S421

Authorised Representative

Wilkinson Star Limited
Shield Drive, Wardley Industrial Estate
Worsley, Salford M28 2WD
Tel +44 161 793 8127

Signature

Dr John A Wilkinson OBE

Position Chairman

Date



Company Stamp

Manufacturer

Shenzhen Jasic Technology Co Ltd
No3 Qinglan, 1st Road
Pingshan District
Shenzhen, China

Signature

Shenzhen Jasic Technology Co Ltd

Position

Date



Company Stamp

Handwritten signature and date: Mar 2022



STATEMENT OF WARRANTY

All new JASIC EVO2.0 welding, plasma cutters and multi-process machines are sold through our partner Wilkinson Star Limited within the United Kingdom and Ireland shall be warranted to the original owner, non transferable, against failure due to defective materials or production.

The warranty period is 5 years following the date of purchase and we recommend you register your product online within 28 days of purchase.

The original invoice is documentation for the standard warranty period. The warranty period is based on a single shift pattern.

Defective units shall be repaired or replaced by the company at our workshop. The company may opt to refund the purchase price (less any costs and depreciation due to use and wear).

The company reserves the right to alter the warranty conditions at any time with effect for the future.

A prerequisite for the full warranty is that products are operated in accordance with the operating instructions supplied, observing the relevant installation and any legal requirements recommendations and guidelines and carrying out the maintenance instructions shown in the operator manual. This should be carried out by a suitably qualified competent person.

Warranty claims will only be accepted from authorised Jasic distributors and in the unlikely event of a problem this should be reported to the technical support team to review the claim.

The customer has no claim to loan or replacement products whilst repairs are being performed.

The following falls outside the scope of the warranty:

- Defects due to natural wear and tear
- Failure to observe the operating and maintenance instructions
- Connection to an incorrect or faulty mains supply
- Overloading during use
- Any modifications that are made to the product without the prior written consent
- Software errors due incorrect operation
- Any repairs that are carried out using non-approved spare parts
- Any transport or storage damage
- Direct or indirect damage as well as any loss of earnings are not covered under the warranty
- External damage such as fire or damage due to natural causes e.g. flooding
- Warranty repairs carried out by non-authorized Jasic distributors.

NOTE: Under the terms of the warranty, welding torches, their consumable parts, wire feed unit drive rolls and guide tubes, work return cables and clamps, electrode holders, connection and extension cables, mains and control leads, plugs, wheels, coolant etc. are covered with a 3 month warranty.

Jasic shall in no event be responsible for any third party expenses or expenses/costs or any indirect or consequential expenses/costs.

Jasic will submit an invoice for any repair work performed outside the scope of the warranty. A quotation for any non warranty will be raised prior to any repairs being carried out.

The decision about repair or replacement of the defective part(s) is made by Jasic. The replaced part(s) remain(s) Jasic property.

Warranty extends only to the machine, its accessories and parts contained inside. No other warranty is expressed or implied. No warranty is expressed or implied in regards to the fitness of the product for any particular application or use.

If in our judgment you fail, or we suspect that you have failed, to comply with any term or provision of the product warranty terms, we reserve the right to deny you access to our services (or any part thereof).

For further information on Jasic product warranty terms and product warranty registration please visit:

www.jasic.co.uk/warranty-information

www.jasic.co.uk/warranty-registration

SCHEMATICS

EP-45

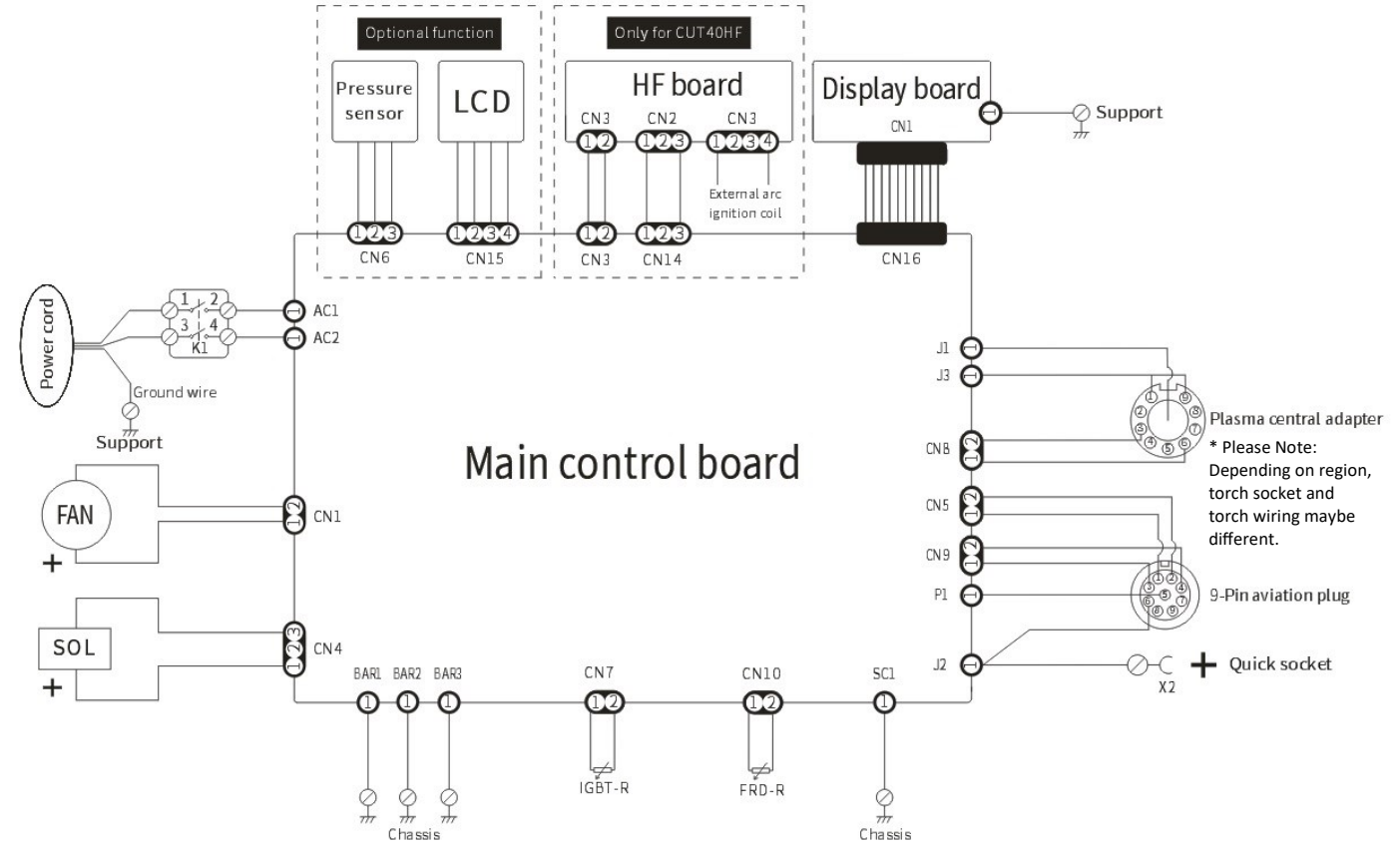

EP-45SC

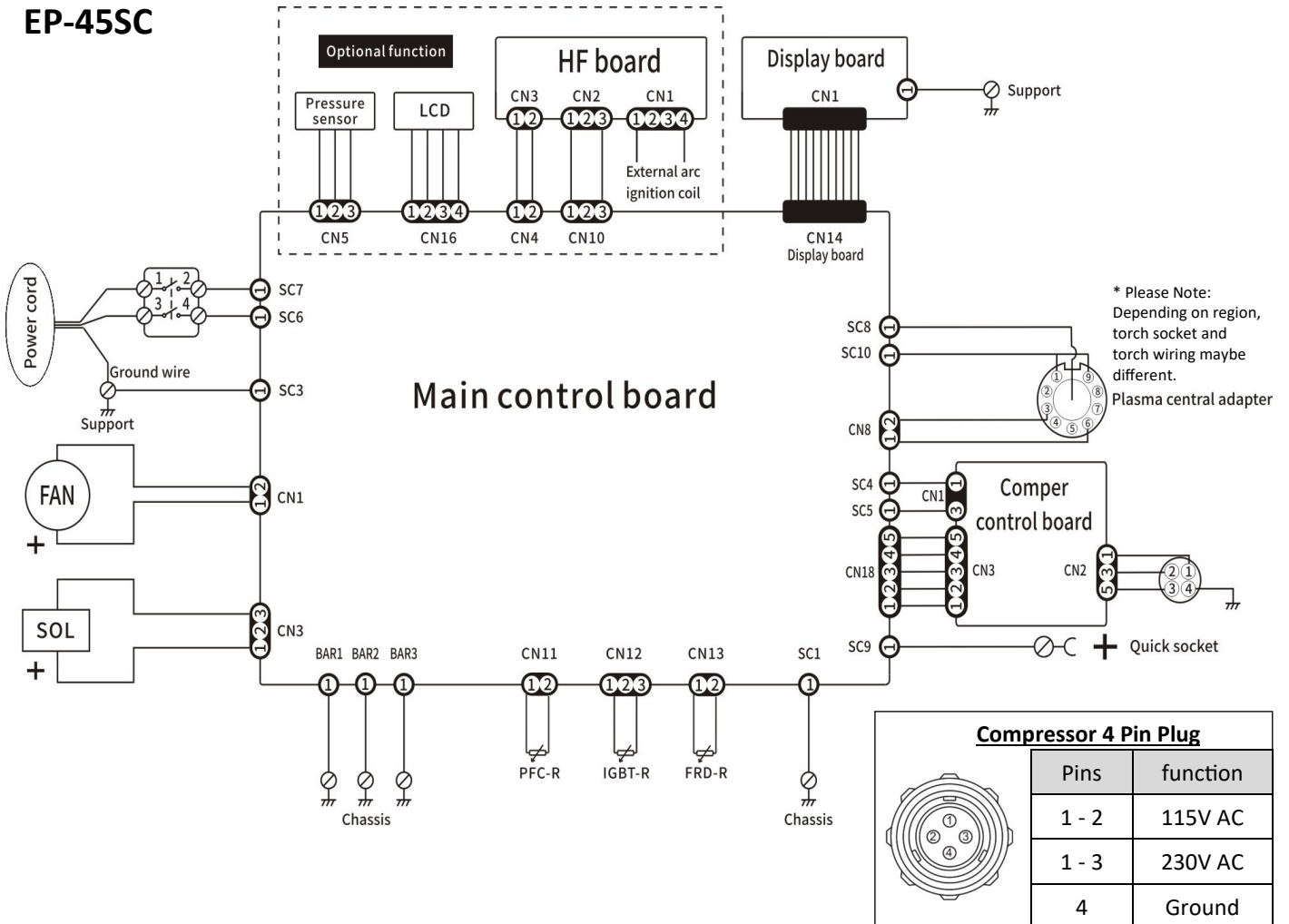

Compressor 4 Pin Plug

Pins	function
1 - 2	115V AC
1 - 3	230V AC
4	Ground



Wilkinson Star Limited

Shield Drive
Wardley Industrial Estate
Worsley
Manchester
UK
M28 2WD

+44(0)161 793 8127



Jasic.co.uk

 **JASIC®** | Passionate About Your Welding

www.jasic.co.uk

April 2023 Issue 1