

# MXL Torches

## Water-cooled Industrial Series



The next generation of MXL torches has been completely redesigned to give users an improved look, feel and performance with all models when used in industrial applications. All consumables are standard Euro style.

- High-quality torch for industrial use
- Ergonomic handle with knuckle joint
- Both gas and water-cooled models available. Please see separate fact sheet and manual

Visit [esab.com](http://esab.com) for more information.



### Industry

- Ship and Offshore Yards
- Repair and Maintenance
- Steel Industry
- Industrial and General Fabrication
- Automotive



*With an ergonomic and well balanced handle with soft grip areas, the new MXL torch variants ensure best comfort for the welder.*

<b>Specifications</b>		
<b>Description</b>	<b>MXL 411W</b>	<b>MXL 511W</b>
Cooling	Water	
Welding Output Mixed Gas	350 A at 100%	450 A at 100%
Welding Output CO <sub>2</sub>	400 A at 100%	500 A at 100%
Wire Diameter	1.0 – 1.6 mm	
Certification Mark (Standards)	CE (IEC 60974-7)	
Operating Temperature	-10 to +40 °C	
Cable Length	3 m, 4 m, 5 m	

<b>Ordering Information</b>			
<b>Description</b>	<b>3 m</b>	<b>4 m</b>	<b>5 m</b>
MXL 411W with Euro Connection	0700025250	0700025251	0700025252
MXL 511W with Euro Connection	0700025260	0700025261	0700025262

<b>Wear Parts – Liners</b>			
<b>Description</b>	<b>Part Number</b>	<b>MXL 411W</b>	<b>MXL 511W</b>
<b>Steel liner</b>			
0.8 – 1.0, Blue, 3 m	0700200085	x	x
0.8 – 1.0, Blue, 4 m	0700200086	x	x
0.8 – 1.0, Blue, 5 m	0700025800	x	x
1.0 – 1.2, Red, 3 m	0700200087*	x	x
1.0 – 1.2, Red, 4 m	0700200088*	x	x
1.0 – 1.2, Red, 5 m	0700025801*	x	x
1.2 – 1.6, Yellow, 3 m	0700025802	x	x
1.2 – 1.6, Yellow, 4 m	0700025803	x	x
1.2 – 1.6, Yellow, 5 m	0700025804	x	x
<b>PTFE liner (for Aluminium)</b>			
1.0 – 1.2, Red, 3 m	0700200091	x	x
1.0 – 1.2, Red, 4 m	0700200092	x	x
1.0 – 1.2, Red, 5 m	0700025812	x	x
1.2 – 1.6, Yellow, 3 m	0700025813	x	x
1.2 – 1.6, Yellow, 4 m	0700025814	x	x
1.2 – 1.6, Yellow, 5 m	0700025815	x	x
<b>PA/Bronze-Liner (for aluminium and stainless steel)</b>			
0.8 – 1.0, Anthracite 3 m	0700025816	x	x
0.8 – 1.0, Anthracite 4 m	0700025817	x	x
0.8 – 1.0, Anthracite 5 m	0700025818	x	x
1.2 – 1.6, Anthracite 3 m	0700025819	x	x
1.2 – 1.6, Anthracite 4 m	0700025820	x	x
1.2 – 1.6, Anthracite 5 m	0700025821	x	x

\* Supplied as standard

\*\*For complete list of wear and spare parts please see separate manual or spare parts list.

# MXL Torches

## Wear Parts

No.	Description	Part Number	MXL 411W	MXL 511W
1	Gas Nozzle Conical	0700025295 (Ø 16 mm)*	x	x
1	Gas Nozzle Tapered	0700025296 (Ø 14 mm)	x	x
1	Gaz Nozzle Cylindrical	0700025297 (Ø 20 mm)	x	x
1	Gas Nozzle Tapered M6	0700025298 (Ø 12 mm)	x	x
3	Gas Diffusor Black	0700025293*	x	x
3B	Gas Diffusor Ceramic	0700025294	x	x
4B	Tip Adaptor M6	0700025292	x	x
4	Tip Adaptor M8	0700025291*	x	x

\* Supplied as standard

## Wear Parts – Contact Tips

No.	Description	MXL 411W / MXL 511W		
		Cu	CuCrZr	Alu Cu
2B	Contact Tip M6 x 28 Ø 0.8	0700200068	0700200081	
2B	Contact Tip M6 x 28 Ø 0.9	0700200069	0700200082	
2B	Contact Tip M6 x 28 Ø 1.0	0700200070	0700200083	0700025273
2B	Contact Tip M6 x 28 Ø 1.2	0700200071	0700200084	0700025274
2	Contact Tip M8 x 30 Ø 0.8	0700025275	0700025280	
2	Contact Tip M8 x 30 Ø 0.9		0700025281	
2	Contact Tip M8 x 30 Ø 1.0	0700025276	0700200103	0700025286
2	Contact Tip M8 x 30 Ø 1.2	0700025277*	0700200104	0700025287
2	Contact Tip M8 x 30 Ø 1.4	0700025278	0700025284	
2	Contact Tip M8 x 30 Ø 1.6	0700025279	0700025285	0700025288

\* Supplied as standard

For complete list of wear and spare parts please see separate manual or spare parts list.

## MXL 411W / MXL 511W

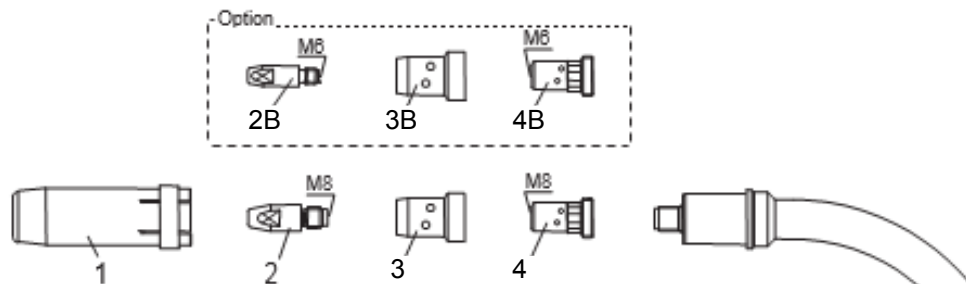

# MXL Torches

## Spare Parts

No.	Description	Part Number	MXL 411W	MXL 511W
201	Torch Neck MXL 411W	0700025203	x	
202	Torch Neck MXL 511W	0700025204		x
203	Handle Complete Expert Plus	0700025902	x	x
204	Cable Support cpl.	0700025971	x	x
205	Central Connector W	0700025970	x	x
206	Quick Connector	0700025973	x	x
207	Hose Clamp w/ Ring Ø 8.7	0700025974	x	x
208	Hose Clamp w/ Ring Ø 9.0	0700025975	x	x
209	Hose Clamp w/ Ring Ø 9.5	0700025976	x	x
210	Clamping Ring Outer Cover	0700025972	x	x
211	PVC-Gas Hose, Black, 4.5 x 1.5 mm	0700025993	x	x
212	PVC hose, Braided, Black, 5 x 1.5 mm	0700025994	x	x
213	Fabric Outer Cover	0700025992	x	x

## Spare Parts - Cables

No.	Description	3 m	4 m	5 m
214	Water-power Cable, Blue	0700025983	0700025984	0700025985
215	Wire Conduit, Yellow	0700025986	0700025987	0700025988
216	Control Cable cpl.	0700025989	0700025990	0700025991
217	Cable Assembly	0700025980	0700025981	0700025982

For complete list of wear and spare parts please see separate manual or spare parts list.

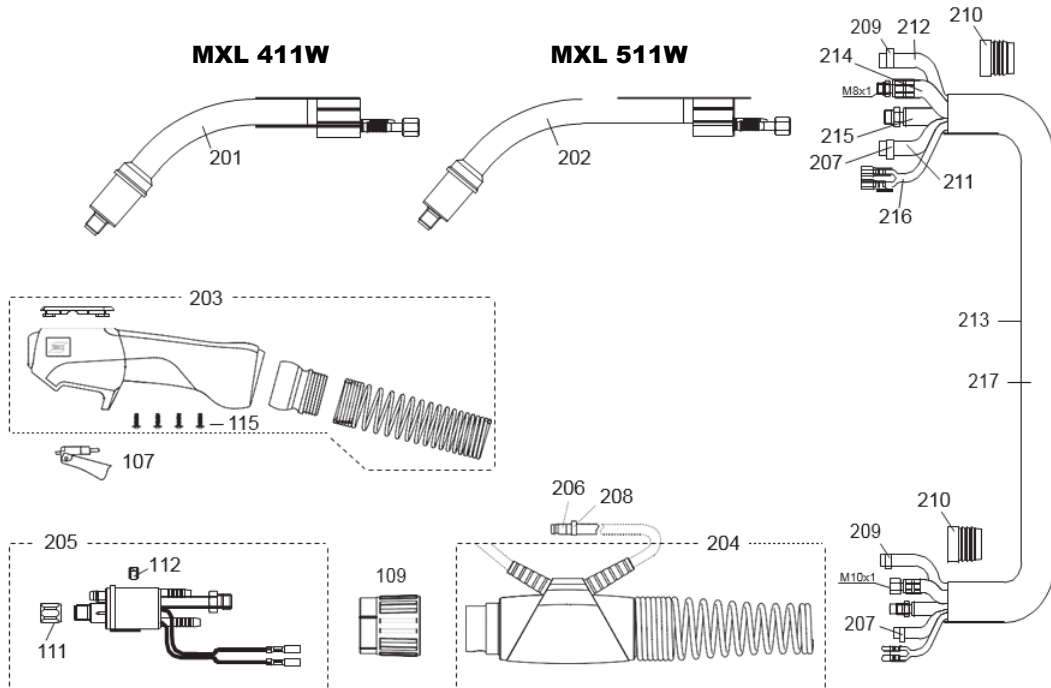

ESAB / esab.com

