

Weldability[®]

Operating Instructions

ProtectoAutoclenz

ProtectoAutoclenzTwin

Weldability sif

Peters House, The Orbital Centre
Icknield Way, Letchworth Garden City
Hertfordshire

SG6 1ET

Tel.: +44 (0) 845 862 2620
Fax: +44 (0) 800 970 7757

E-Mail: sales@weldability-sif.com

www.weldability-sif.com

Contents

1	Drawing/ Description of the components	3
2	Preface	4
3	Intended use of the ProtectoAutoclenz	5
4	Safety instructions	5
5	Storage, transport and setting-up of the device	7
6	Commissioning	7
6.1	Mounting of the collecting elements	1
6.2	Connection of the compressed-air supply	8
6.3	Mounting the baffle plate for exhaust air (only for ProtectoAutoclenz-1)	8
6.4	Connection of the device	8
7	Operation and operating condition	9
8	Maintenance	10
8.1	Cleaning of the filter cartridge	10
8.2	Compressed air supply	11
8.3	Emptying of the dust collecting tray	12
8.4	Discharge of condensation water	13
8.5	Changing of the filter cartridge	13
8.6	Precoating new filter cartridges	15
8.7	Emptying of the compressed air tank	15
9	Fault removal and fault diagnosis	16
10	Dismantling/disposal	17
11	List of spare parts	18
12	Technical data	19
13	Declaration of conformity for Protecto Autoclenz	20
14	Briefing protocol for users of the device	21

1 Drawing/ Description of the components

The version ProtectoAutoclenzTwin (2 arms, 2 cartridges) is shown.

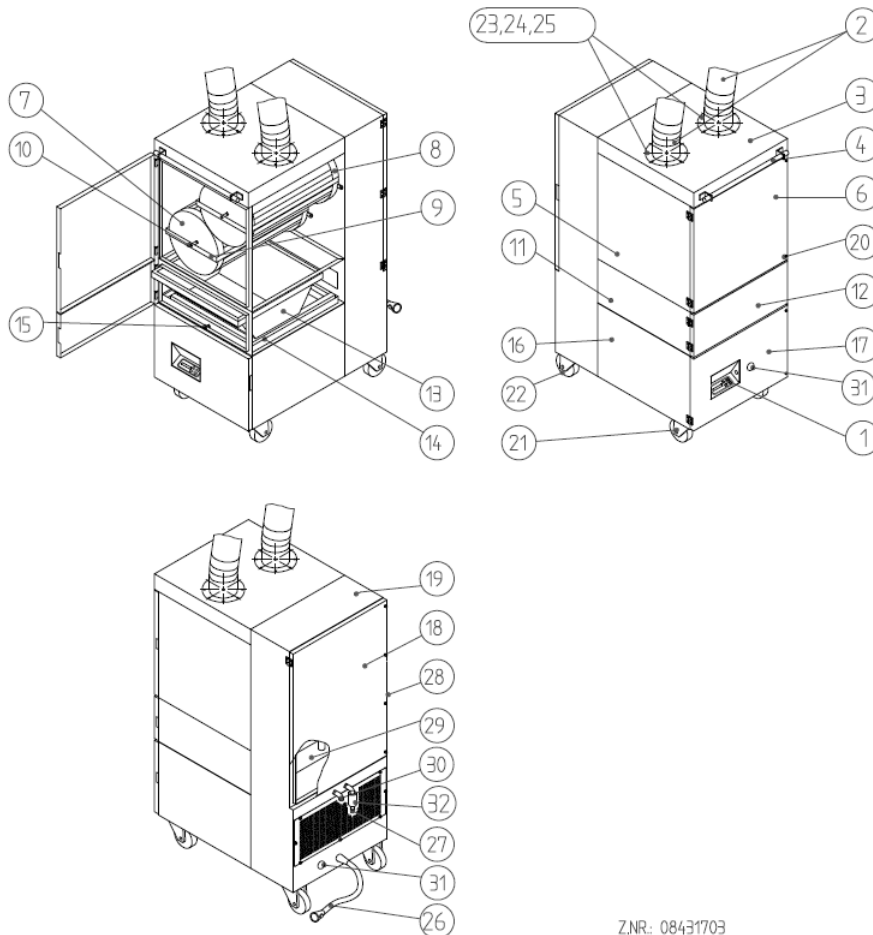

Z.NR: 08431703

Pos.1	Membrane keyboard	Pos.16	Fan casing
Pos.2	Suction arms with extractor cowl or pipe connection	Pos.17	Fan door
Pos.3	Casing cover	Pos.18	Pneumatics door
Pos.4	Handle	Pos.19	Pneumatics casing
Pos.5	Cartridge casing	Pos.20	Cap nut for the cartridge door
Pos.6	Cartridge door	Pos.21	Swivel castor with brake
Pos.7	Filter cartridges (for unit with 1 arm only 1 filter cartridge)	Pos.22	Swivel castor
Pos.8	Cartridge guide	Pos.23	Screw for attaching arm
Pos.9	Cartridge holder	Pos.24	Split washer for attaching arm
Pos.10	Clamping screw for the filter cartridge	Pos.25	Rotary flange
Pos.11	Drawer casing	Pos.26	Power cord with power plug and indicator for direction of rotation: red
Pos.12	Drawer door	Pos.27	End piece grommet
Pos.13	Dust collecting tray	Pos.28	Cap nut for pneumatics door
Pos.14	Lifting device	Pos.29	Compressed air tank
Pos.15	Clamping screw for the dust collecting bin	Pos.30	Discharge valve
		Pos.31	Signal hooter
		Pos.32	Check valve

2 Preface

Congratulations on your purchase of the filter unit of the ProtectoAutoclenz series!

Our engineers ensure through continuous development that our filter systems correspond with the latest state-of-the-art. Nevertheless misapplication or malfunction can lead to risks for your safety.

Therefore, please note the following for a successful use of the filter system:



Read these instructions before using the system and follow the safety instructions to avoid injuries!

Non-intended use of the system may lead to severe injury or death!

Save this manual carefully! Consider this manual to be part of the product!

Note all instructions on the product!

Note the local regulations at the installation location!

Refer to the manufacturer's specifications. If you have any doubts, please contact the manufacturer:

Tel.: +44 (0) 845 862 2620

Fax: +44 (0) 800 970 7757

We wish to thank you for your confidence and wish you great success!

3 Intended use of the ProtectoAutoclenz

The filter unit is mainly used to extract and filter dust and fumes. The filter unit is suitable for the separation of welding fumes of steels with an alloying of for example nickel and chrome of 30% that are produced during the processing of steels and thus fulfils the highest welding fume class "W3" according to DIN EN ISO 15012-1.



Improper use of the device can damage parts of it and be a danger to life and limb!

The device must not be used for the extraction of oil-laden welding fume, explosive dust and gases, hybrid mixtures, glowing or burning substances, gases, water, etc. The device must not be operated in explosive zones. (If you have any doubts, please contact the manufacturer!)

The polluted air is captured by the extractor cowl (or the capture element) and gets through the suction arm (or the suction hose) into the filter unit. Here, the particles are collected on the surface of the integral filter cartridge. The cleaned air is sucked by the fan and returned into the working space via the exhaust grid on the back side.

Please note:

The degree of saturation of the filter cartridge (pos. 7) is monitored electronically. In order to maintain the suction capacity of the unit, the filter cartridge is cleaned automatically once a preset value is reached.

Via the integral pneumatic cleaning the compressed air is homogeneously dispersed on the filter surface which eliminates the filter cake. (see chapter 8.1: "Cleaning of the filter cartridge")

The disrupted dust is collected in a dust collecting tray and can be disposed from there. (see chapter 8.3: "Emptying of the dust collecting tray")

4 Safety instructions

The machine is designed according to the state of the art and the recognised safety regulations. Nevertheless, its use may create dangers to life and limb of the user or third parties or impairments of the machine or other tangible assets. Therefore, read and follow the safety instructions before using the product.

The operator must make sure that personnel authorized by him is familiar with all the safety instructions of this manual. The operator must ensure that all types of work on the machine are only carried out by authorized and qualified personnel. For that purpose we recommend to use the briefing protocol on the final page.

- Read and follow these instructions before using the device!
- Keep these operating and maintenance instructions carefully!
- Do not use the device to exhaust highly flammable or explosive gases!
- Do not use the device in explosive zones, as for example zone 0, zone 1, zone 2, zone 20, zone 21, zone 22!
- Do not use the device to exhaust burning or glowing materials, as for example cigarettes, matches, metallic dust or chips, paper, cleaning wipes, etc.!
- Do not use the device to exhaust burning or ignitable materials, as for example oil or oil mist, greases, separating agents (e.g. silicone spray), detergents, etc.!
- Do not use the device to exhaust aggressive materials!
- Do not use the device to exhaust liquids of any kind!
- Do not use the device to exhaust organic materials without the written approval of the manufacturer!

- Depending on the setting of the control, there can be an automatic postcleaning of the filter cartridges when the device is switched off. To avoid the dust escaping from the extractor cowl of the suction arm, the throttle valve of the extractor cowl must always be closed once the device is switched off (see therefore the indications of the chapter “Operation and operating condition”).
- In case of fire use an approved fire extinguisher.
- Protect the connecting plug and the mains lead against heat, moisture, oil and sharp edges!
- Mind the admissible supply voltage! (Refer to the type plate!)
- Use only original Weldability spare parts!
- Do not use the device without a filter!
- Before opening the device disconnect the filter unit from the main power supply!
- Before starting any repair or maintenance work, empty the compressed air tank (see chapter 8.7: “Emptying of the compressed air tank”).
- The exhaust opening must not be obstructed or covered!
- Always make sure that the device stands firmly and that the brakes on the swivel castors are put on!
- Disconnect the filter unit from the main power supply in case of cleaning or maintaining the device or changing of component parts!
- Dispose of the filter element in accordance with legal requirements!
- The mains cable of the device must be checked regularly for signs of damage!
- The device must not be used if the condition of the mains cable is not faultless!
- Use only dry and oil-free compressed air and an operating pressure of min. 3 bar and max. 4 bar.
- The extractor cowl must follow the weld seam, if possible by using the movement of the welding fume caused by thermal influences. Connections between the workpiece and the extractor cowl (and in general between the workpiece and the filter unit) must be avoided, so that the welding current cannot flow back to the welding machine through the protective conductor of the filter unit.
- The maximum permitted distance to the welding point must not exceed 25 cm.
- Do not use the filter unit if any components are defective, missing or damaged. In any of these cases please contact the Weldability service department by calling +44 (0) 845 862 2620.
- During suction of carcinogenic welding smoke as for example from nickel or chrome containing materials the ventilation requirements of the TRGS 560 “Air recirculation in connection with the treatment of carcinogenic hazardous materials” must be met!

5 Storage, transport and setting-up of the device

Falling or unmounted parts of the device may create danger to life and limb.

The device must be secured against tilting and slipping when it is stored or transported. Do not stand under or next to the floating load. Direct all people out of the danger area. Lift trucks, forklift trucks and transport cranes must have a sufficient minimum load bearing capacity.

The device must be set up on a suitable underground. Otherwise falling or functional impairment may create danger to life and limb.

The underground must be horizontal and free from vibration. The operator must check the bearing capacity of the underground.

The device must be stored in a dry place and protected against moisture during transport.

6 Commissioning

The filter unit is, with the exception of the collecting element, delivered completely assembled.

The collecting element, e.g. the suction arm, must be assembled to the device before the commissioning.

6.1 Mounting of the collecting elements

The collecting element, e.g. the suction arm or suction hose, must be fixed to the intake nozzle or the casing cover.

If using a suction arm it is attached with the help of the supplied rotary flange (pos. 25), the screws (pos. 23) and the split washers (pos. 24).

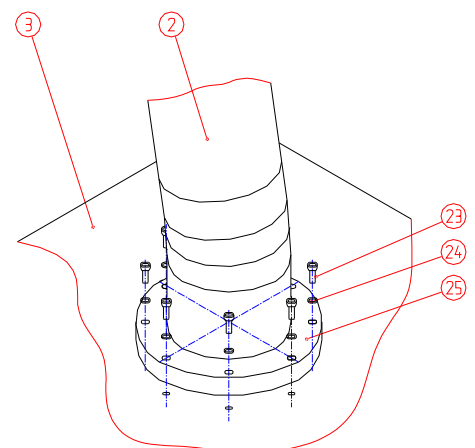

Please note:

Be sure that the nozzle is rotatable now!

6.2 Connection of the compressed-air supply

- External supply only with approved compressed-air hose!
- Connect the compressed-air hose to the end piece grommet (pos. 27) with the help of a hose coupling.
- The operating pressure must be of min. 3 bar and max. 4 bar.
- Use only dry and oil-free compressed air.
- The external compressed-air supply must allow the compressed air tank to reach the operating pressure within the valve pause time (see separate operating manual of the control).

Please note:

Before starting any repair or maintenance work, empty the compressed air tank and disconnect the filter unit from the main power supply and secure it against being switched on again. If the pneumatic system is leaky, the filter unit must not be operated. Without a compressed air supply, the filter cartridge gets polluted very quickly and the unit switches to disturbance (filter alarm)!

6.3 Mounting the baffle plate for exhaust air (only for Protecto Autoclenz with 1 arm)

Before the commissioning, the supplied baffle plate for exhaust air must be mounted. Therefore hang up the baffle plate for exhaust air.

(The ProtectoAutoclenz with 2 arms does not need a baffle plate for exhaust air)

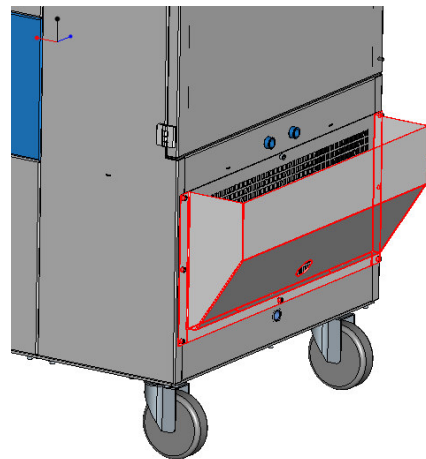

6.4 Connection of the device

- Connect the filter unit to the main power supply. (Refer to the indications on the type plate!)

7 Operation and operating condition

The operation of the filter unit is carried out on its membrane keyboard with an electronic text display. All functions of the device are set up on it.

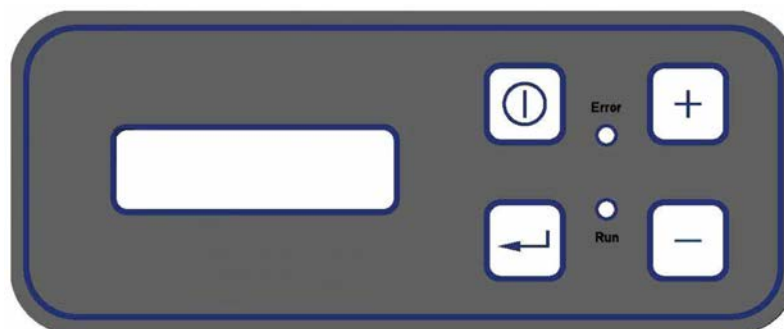

Please note:

For program settings, menu navigation, etc. of the device please refer to the enclosed operating manual "ControlUnit".

According to the settings of the control "ControlUnit" there can be automatic postcleanings of the filter cartridges when the device is turned off. To avoid dust escaping from the extractor cowl of the suction arm, the throttle valve of the extractor cowl must always be closed when the device is turned off.

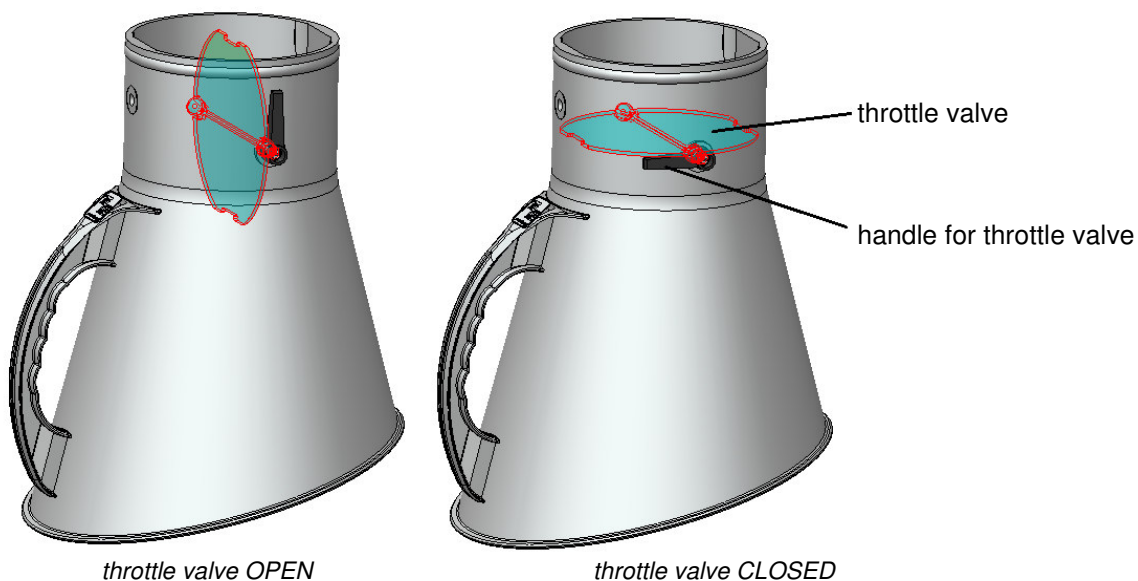

8 Maintenance

Through filtration of the dust particles, the saturation of the filter cartridge rises and the suction performance is reduced.

The saturation of the filter cartridge (pos. 7) is electronically monitored. To keep the admissible suction capacity of the device, the filter cartridge is automatically cleaned when the default value is reached. (see chapter 8.1: "Cleaning of the filter cartridge")

The dust particles are blown from the inside to the outside on the side of the purified gas. The detached filter cake falls into the dedicated dust collecting tray (pos. 13). (see chapter 8.3: "Emptying of the dust collecting tray"). The service life of the filter cartridge depends very strongly on the operating conditions and can therefore not be predicted.

If despite cleanings the filter unit permanently shows "filter alarm" at the display and the signal hooter (pos. 31) rings, the filter cartridge must be replaced. (see chapter 8.5: "Changing of the filter cartridge")

Please note:

The operation of the filter unit must be stopped during the changing of the filter cartridge.

For all repair or maintenance work it must be ensured that the device will not start a sudden filter cleaning process. Therefore before starting any repair or maintenance work, disconnect the device from the main power supply and from the compressed air system. Also empty the compressed air tank as it can be under pressure even without compressed air supply. (see chapter 8.7: "Emptying of the compressed air tank")

The changing of the filter cartridge and the disposal must only be carried out in well-ventilated rooms and while wearing an appropriate respiratory mask! The same applies to the emptying of the dust collecting tray. We recommend: respiratory protection half mask DIN EN 141/143 protection level P3. Wearing appropriate protective gloves is recommended as well.

Dispose of the filter according to legal regulations! The polluted filter elements must be packed into an appropriate container (e.g. PE bag). Bags are optionally available (see spare parts list)! We recommend having PE bags in stock.

All maintenance work must be carried out by authorised and qualified personnel!

A re-start-up of the device may only be carried out if it is ensured that the filter unit corresponds in its functions to the original state. Repairs must only be carried out by employees of Weldability or staff authorized by the operator after consultation with Weldability.

The operator is in accordance to national regulations obliged to carry out replications and functional tests. Otherwise malfunctions of the device can lead to dangers. If not defined by other national regulations, we recommend tests of the electric and pneumatic pipes every 6 months. If the pneumatic pipe is leaky, the filter unit must not be operated anymore.

Furthermore, we recommend monthly visual inspections and functional tests of the device. This includes the control of all movable parts such as doors and the fan to check if they work well and frictionless.

8.1 Cleaning of the filter cartridge

The saturation of the filter cartridge (pos. 7) is electronically monitored. To keep the admissible suction capacity of the device, the filter cartridge is automatically cleaned when the default differential pressure value is reached. If after the cleaning of the filter cartridge the default differential pressure value is still not undercut, a new cleaning starts.

If the maximal admissible filter resistance is reached, the filter unit shows “filter alarm”. If despite the automatic cleaning of the filter cartridge the alarm value can not be undercut, the filter cartridge must be replaced. (see chapter 8.5: “Changing of the filter cartridge”).

The differential pressure values in the control that initiate a cleaning or a filter alarm are default values that are adapted to the filter unit or the filter cartridges. For detailed information about the mode of operation of the control, please refer to the separated operating manual “ControlUnit”.

During the automatic cleaning the filter unit stays in service.

The service life of the filter cartridge depends very strongly on the operating conditions and can therefore not be predicted.

Please note:

The manual beating out and washing out leads to the destruction of the filter medium and is not allowed as the pollutants get into the indoor air!

Depending on the setting of the control, there can be an automatic postcleaning of the filter cartridges when the device is switched off. To avoid the dust escaping from the extractor cowl of the suction arm, the throttle valve of the extractor cowl must always be closed once the device is switched off (follow the indications of the chapter “Operation and operating condition”).

8.2 Compressed air supply

To ensure a troublefree operation of the device, there must be a defect-free compressed air supply.

- Use only dry and oil-free compressed air.
- The condensation water produced in the compressed air tank (pos. 29) must be emptied regularly. (see chapter 8.4: “Discharge of the condensation water”)
- If an upstream water separator is used (optionally available), it must be controlled and, if necessary, emptied regularly.
- The pneumatic parts of the device must be regularly checked for tightness.
- Use the external compressed air supply with an admissible compressed air pipe and an operating pressure of min. 3 bar and max. 4 bar.
- In the pneumatics casing is a compressed air tank with a volume of 15 l serving as a reserve. The content is sufficient for one cleaning procedure. After the cleaning procedure compressed air for the next cleaning interval streams in. The check valve (pos. 32) ensures that the compressed air stays inside the compressed air tank even in case of interruption of the compressed air supply.

Please note:

Before starting any repair or maintenance work, empty the compressed air tank and disconnect the filter unit from the main power supply. (see chapter 8.7: “Emptying of the compressed air tank”).

If the pneumatic system is leaky, the filter unit must not be operated.

Without a compressed air supply, the filter cartridges gets polluted very quickly and the unit switches to disturbance (filter alarm)!

8.3 Emptying of the dust collecting tray

The dust collecting tray (pos. 13) must be cleaned regularly. The interval depends on the produced amount of dust, but it must be emptied at least once a week. The dust collecting tray may only be filled to 25% maximal! (If you have any doubts, please contact the manufacturer!)

Please note:

The filter cartridge must be cleaned before the emptying of the dust collecting tray. The cleaning is carried out with menu item 3 of the control „Manual start of cleaning“. The procedure is described in the supplied operating manual “ControlUnit”! The cleaning must be carried out 3 times. Please wait for 5 minutes after the cleaning of the filter cartridge before opening the drawer door (pos. 12).

- Switch off the filter unit on the touch-sensitive membrane keyboard .
- Disconnect the filter unit from the main power supply.
- The compressed air tank must be emptied before starting any maintenance work. (see chapter 8.7: “Emptying of the compressed air tank”)
- Before emptying the dust collecting tray hold ready an appropriate container (e.g. PE bag or plastic sack) for disposal.

Please note:

Bags are optionally available (see spare parts list)! We recommend having PE bags in stock.

- Open the drawer door (pos. 12).
- Turn low the lifting device (pos. 14) with the help of the clamping screw (pos. 15).
- Pull out the dust collecting tray (pos. 13).
- Take out the dust collecting bag with the collected dust. Close it with a cable tie or something similar before taking it out.
- Store and dispose of the dust collecting bag with the dust in an appropriate bag according to legal requirements.
- Put a new plastic bag into the dust collecting tray in a way that the opening of the bag is slipped over the edge of the dust collecting tray.
- Push the dust collecting tray (pos. 13) to the limit stop into the drawer casing (pos. 11).
- Turn up the lifting device (pos. 14) with the help of the clamping screw (pos. 15) in a way that the dust collecting tray (pos. 13) seals tightly. (Check the seal under the cartridge casing (pos. 5) for damages.)
- Close the drawer door (pos. 12).
- Connect the filter unit to the main power supply. (Refer to the type plate!)
- Switch on the filter unit on the touch-sensitive membrane keyboard .

Please note:

The emptying of the dust collecting tray may only be carried out in well-ventilated rooms and while wearing an appropriate respiratory mask!

Before starting any repair or maintenance work, empty the compressed air tank.



We recommend: respiratory protection half mask DIN EN 141/143 protection level P3.

The operations mentioned above must only be carried out by trained employees.

Dispose of the dust according to legal requirements!

8.4 Discharge of condensation water

The condensation water produced in the compressed air tank (pos. 29) must be emptied regularly as followed:

- Switch off the filter unit on the touch-sensitive membrane keyboard .
- Disconnect the filter unit from the main power supply.
- Disconnect the filter unit from the external compressed air supply.
- Open the discharge valve (pos. 30) and fill the condensation water in an appropriate container. (By opening the discharge valve, the compressed air in the compressed air tank (pos. 29) escapes.)
- Store and dispose of the condensation water in an appropriate container according to legal requirements.
- Close the discharge valve (pos. 30).
- Connect the filter unit to the external compressed air supply.
- Connect the filter unit to the main power supply. (Refer to the type plate!)
- Switch on the filter unit on the touch-sensitive membrane keyboard .

Please note:

The operations mentioned above must only be carried out by trained employees!

Dispose of the condensation water according to legal requirements!

8.5 Changing of the filter cartridge

If the maximum admissible filter resistance is reached, the filter unit shows “filter alarm”. If despite the automatic cleaning of the filter cartridge the alarm value can not be undercut, the filter cartridge must be replaced. (see chapter 8.5: “Changing of the filter cartridge”).

The differential pressure values in the control that initiate a cleaning or a filter alarm are default values that are adapted to the filter unit or the filter cartridges. For detailed information about the mode of operation of the control, please refer to the separate operating manual “ControlUnit”.

Please note:

The filter cartridge must be cleaned before being changed. The cleaning is carried out as a manual cleaning with the help of the control. The procedure is described in the supplied operating manual “ControlUnit”! The cleaning must be carried out 3 times.

Please wait for 5 minutes after the cleaning of the filter cartridge before opening the drawer door (pos. 12).

- Switch off the filter unit on the touch-sensitive membrane keyboard .
- The changing of the filter cartridge must be carried out by two people.
- Disconnect the filter unit from the main power supply.
- Before starting any maintenance work empty the compressed air tank. (see chapter 8.7: “Emptying of the compressed air tank”)
- Disconnect the filter unit from the external compressed air supply.
- Before changing the filter cartridges hold ready an appropriate container (e.g. PE bag or plastic sack) for disposal.

Please note:

The polluted filter cartridges must be packed into an appropriate container (e.g. PE bag). Bags are optionally available (see spare parts list)! We recommend having PE bags in stock.

- Empty the compressed air tank (pos. 29) by opening the discharge valve (pos. 30). (By opening the discharge valve, some condensation water can leak out.)
- Resolve the cap nuts (pos. 20) and open the cartridge door (pos. 6).
- Resolve the clamping screw (pos. 10) of the cartridge holder (pos. 9) and slip the disposal bag over the cartridge holder and the filter cartridge.
- Hook off the cartridge holder (pos. 9) and take it out of the device together with the filter cartridge (pos. 7) and the disposal bag.
- Resolve the cylinder nut outside on the cartridge's bottom and take the displacer out of the filter cartridge without generating dust. Therefore do not touch the cylinder nut directly with your hands, but grab it from the outside through the bag.
- Pull the cartridge holder out of the disposal bag past the filter cartridge without generating dust.
- Put the displacer into the new filter cartridge in way that the screw of the displacer is put through the whole of the cartridge's bottom. Fasten the displacer with the cylinder screw from the outside.

Please note:

Use only Weldability replacing filters!

- Push the new filter cartridge with the displacer into the cartridge guide (pos. 8) of the device and hang it up with the cartridge holder.
- Fasten the clamping screw (pos. 10) of the cartridge holder (pos. 9).
- Close the cartridge door (pos. 6) and fasten the cap nuts (pos. 20).
- Connect the filter unit to the external compressed air supply.
- Connect the filter unit to the main power supply. (Refer to the type plate!)
- For a longer service life of the new filter cartridges we recommend to precoat them before the first commissioning. (see chapter 8.6: "Precoating the new filter cartridges")
- Switch on the filter unit on the touch-sensitive membrane keyboard .

Please note:

The changing of the filter cartridge and the disposal must only be carried out in well-ventilated rooms and while wearing an appropriate respiratory mask!

Before starting any repair or maintenance work, empty the compressed air tank.

We recommend: respiratory protection half mask DIN EN 141/143 protection level P3.

The operations mentioned above must only be carried out by trained employees.

Dispose of the filter according to legal requirements!

8.6 Precoating new filter cartridges

We recommend to pre-treat new filter cartridges with filter aid before the first commissioning. The filter aid acts against a caking of the exhausted particles on the filter surface and extends the service life of the filter cartridges.



WARNING

Contact with the filter aid can be a danger to the respiratory tracts, cutaneous irritations or irritations of the eyes. Refer to the manufacturers indications listed here:

<i>Handling:</i>	Avoid dust formation!
<i>Storage:</i>	Close the container firmly before storing it!
<i>Respiratory protection:</i>	Fine dust respirator without protection stage!
<i>Hand protection:</i>	Protective gloves of fabric, rubber or leather!
<i>Eye protection:</i>	Safety glasses with side protection!
<i>Body protection:</i>	Working footwear antistatic!

Unlike the other maintenance work, this step must be carried out while the device is in service and turned on so that the precoat can reach the filter cartridges through the suction.

CAUTION There must not be any compressed air in the compressed air tank and the compressed-air hose must be disconnected from the device. (see chapter 8.7: "Emptying of the compressed air tank")

Switch on the device. The precoat (10g for one square meter filter surface) must be entered via the collecting point.

8.7 Emptying of the compressed air tank

Before starting any repair or maintenance work, empty the compressed air tank as followed:

- Disconnect the filter unit from the main power supply.
- Disconnect the filter unit from the external compressed air supply.
- Open the discharge valve (pos. 30) and fill the condensation water in an appropriate container. (By opening the discharge valve, the compressed air in the compressed air tank (pos. 29) escapes.)
- Store and dispose of the condensation water in an appropriate container according to legal requirements.

Only after finishing all repair and maintenance work reconnect the compressed air tank as followed:

- Close the discharge valve (pos. 30).
- Connect the filter unit to the external compressed air supply.
- Connect the filter unit to the main power supply. (Refer to the type plate!)

Please note:

The operations mentioned above may only be carried out by trained employees!

9 Fault removal and fault diagnosis

In the presented table you can find a list of faults of the device. Fault indications of the control are explained in the separate operating manual.

A re-start of the device may only be carried out if it is ensured that the filter unit corresponds in its functions to the original state. Repairs may only be carried out by employees of Weldability or staff authorized by the operator after consultation with Weldability.

For all repair work refer to the chapters "Safety instructions" and "Maintenance". If you have any doubts, please contact the Weldability service department:

Tel.: +44 (0) 845 862 2620 Fax: +44 (0) 845 970 7757

Fault	Cause	Elimination of defect
No suction capacity (fumes are not sucked off).	Suction hose is not connected.	Connect the suction hose.
	Suction hose is damaged.	Replace the suction hose.
	Suction trajectory is clogged.	Check the suction trajectory and eliminate the defect.
	Cleaned air outlet is covered.	Check the cleaned air outlet and eliminate the defect.
Suction capacity too low (fumes are hardly sucked off).	Filter element saturated.	Replace the filter pack, dispose of the old filter according to the requirements!
	Damage at the suction hose.	Replace the suction hose.
	Suction hose or suction arm not correctly connected.	Check the connection of the suction hose or suction arm and connect it.
	Motor turns into wrong direction.	Change the rotating field of the mains tapping point.
	Cleaned air outlet is narrowed.	Check the cleaned air outlet and eliminate the defect.
	Suction trajectory is narrowed.	Check the suction trajectory and eliminate the defect.
	Throttle valve of the extractor cowl is closed.	Open the throttle valve.
Dust outlet at the cartridge door.	One or several of the door handles are not closed.	Close the door handles.
	The seal between the cartridge door and the cartridge casing is damaged.	The seal must be renewed.
Dust outlet at the suction intake of the suction arm.	The automatic postcleaning of the filter cartridge is activated.	Close the throttle valve of the extractor cowl when the device is switched off.
Device does not start.	Connector power supply is not or wrongly plugged.	Check/plug the connector power supply.
	No power on socket.	Check the power line and eliminate the defect.

10 Dismantling/disposal

The dismantling of the device may only be carried out by employees of Weldability or by employees who are authorized by the operator.

For all dismantling work refer to the indications in the chapter “Safety instructions” and “Maintenance”. If you have any doubts, please contact the Weldability service department:

Tel.: +44 (0) 845 862 2620

Fax: +44 (0) 845 970 7757

- Only trained electricians are allowed to carry out the dismantling of the device, the electrical installation or the power supply.
- Before starting the dismantling of the device, disconnect it from the main power supply and from the external compressed air supply and empty the compressed air tank.
- While working on the device appropriate respiratory protection and protective clothing must be worn. We recommend respiratory protection half mask DIN EN 141/143 protection level P3.
- The pollutants and the filter elements must be disposed of properly.
- Follow the instructions of the manufacturer or contact the manufacturer.

To provide for proper operation of the ProtectoAutoclenz as well as a proper disposal of the extracted dust, we offer the following services:

- Assistance in searching a disposal contractor in your area.
- A list of all disposal companies in Germany can be found on www.bde-berlin.de.
- A maintenance and repair contract
- Customer advisory service by telephone

Do not hesitate to talk about these services with our service department which is available for you 24 hours.

Tel.: +44 (0) 845 862 2620

Fax: +44 (0) 845 970 7757

11 List of spare parts

Designation:	Item number:
Filter cartridge 7,8m ²	10025078
Filter cartridge 10m ²	10025
Star filter cartridge, type easy clean + 12,5m ²	100050125
PE bag to dispose of filter cartridges (4 bags)	10030251702
PE bag to put into dust collecting tray (10 bags)	10030250

12 Technical data

Filter unit		Weldability – ProtectoAutoclenz	
Type		ProtectoAutoclenz	ProtectoAutoclenz Twin
Supply voltage	V	400	
Frequency	Hz	50	
Current type	Ph	3	
Engine performance	kW	1,5	2,2
Max. volumetric flow rate	m³/h	1035	2150
Min. volumetric flow rate	m³/h	700	1160
Max. diminished pressure	Pa	1800	1600
Protection class		IP 54	
ISO - class		F	
Control voltage	V	230	
On-period	%	100	
Width x Depth x Height	mm	665 x 1100 x 1270	665 x 1100 x 1630
Weight	kg	160	190
Type of filter		1 or 2 filter cartridges	
Filter surface of the filter cartridge	m²	7,8 / 10 / 12,5	15,6 / 20 / 25
Removal rate	%	>99	
Mode of cleaning		pulse-jet	
Noise level <small>(Measured acc. to DIN 45635 T1 in 1m distance from the surface of the unit in a clear area at the maximum volumetric flow rate.)</small>	dB(A)	ca. 74	
Ambient temperature	°C	+5 to +35	
Compressed air		External	
Compressed air supply		dry / oil-free	

13 Declaration of conformity for ProtectoAutoclenz

Weldability sif

Peters House, The Orbital Centre
Icknield Way, Letchworth Garden City
Hertfordshire
SG6 1ET

Tel.: +44 (0) 845 862 2620

Fax: +44 (0) 800 970 7757

E-Mail: sales@weldability-sif.com

www.weldability-sif.com

We hereby declare under our sole responsibility that the product mentioned above from the machine no.: 9000010011001 on fulfils the requirements of the following directives:

Machinery Directive: 2006/42/EG

Electromagnetic Compatibility: 2004/108/EG

Pressure Equipment Directive: 97/23/EG

Low Voltage Directive: 2006/95/EG

Applied harmonized standards:

- DIN EN 349
- DIN EN ISO 4414
- DIN EN 12100
- DIN EN 60204 part 1
- DIN EN ISO 13857
- DIN EN ISO 626 part 1

Where applicable other national standards and specifications:

- DIN 45635 part 1
- DIN EN ISO 15012-1

This declaration becomes invalid if the extraction and filter unit is modified without the manufacturer's written consent.

Responsible for technical documentation: Weldability Sif

14 Briefing protocol for users of the device

(This form can be used by the operator to document the briefing of his employees. Briefings should only be carried out by authorized employees. Refer to the indications in the chapter “Safety instructions”).

By signing the form, the briefed employee confirms that he has been briefed in the following points:

Briefing	done
Description of the filter unit	
Operating method and fields of application of the filter unit	
Explanation of the safety instructions	
Methods of operation in case of fire	
Explanation of the control of the filter unit	
Maintenance, change and cleaning of the filter element	
Maintenance of the compressed air supply	
Emptying of the dust collecting tray	
Correct disposal	

Name of the employee (legible)	Signature

Briefing was carried out by (legible): _____

Signature: _____.