

Weldability®

Operating Instructions

Type

ProtectoSmart

with Activated-Carbon

Weldability sif

Peters House, The Orbital Centre
Icknield Way, Letchworth Garden City
Hertfordshire
SG6 1ET

Tel.: +44 (0) 845 862 2620

Fax: +44 (0) 800 970 7757

E-Mail: sales@weldability-sif.com

www.weldability-sif.com

Contents

- 1 Diagram/description of the components 3
- 2 Preface 4
- 3 Function of the ProtectoSmart 5
- 4 Safety instructions 5
- 5 Commissioning 7
 - 5.1 Attaching the extractor fittings 7
 - 5.2 Electrical connection of the unit 8
 - 5.3 Connection of an air outlet pipe 8
- 6 Explanation of the controls 8
- 7 Maintenance 9
 - 7.1 Changing of pre-filter 9
 - 7.2 Changing of particle filter 10
 - 7.3 Changing of the activated-carbon cassette 10
- 8 Disposal 11
- 9 Technical data 12
- 10 Parts list 12
- 11 Declaration of conformity ProtectoSmart 13

1 Diagram/description of the components

ProtectoSmart with 1 suction element

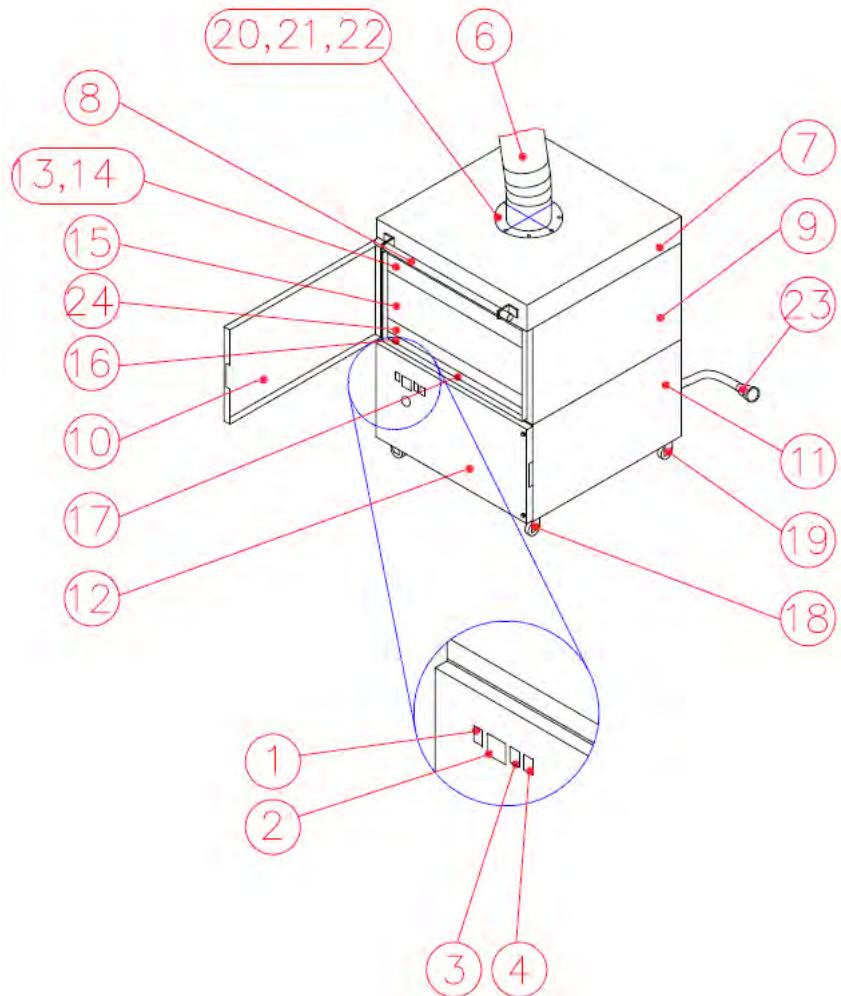

Pos.1	Power switch	Pos.13	Pre-filter tray
Pos.2	Operating hour counter	Pos.14	Pre-filter element
Pos.3	Operating status lamp: green	Pos.15	Particle filter
Pos.4	Volume flow control lamp : red	Pos.16	Lifting device
Pos.6	Suction arm with suction hood or connecting piece	Pos.17	Lock for lifting device
Pos.7	Lid	Pos.18	Castor with brake
Pos.8	Hand grip	Pos.19	Castor
Pos.9	Filter housing	Pos.20	Bolt for attaching arm
Pos.10	Filter door	Pos.21	Washer for attaching arm
Pos.11	Ventilator housing	Pos.22	Rotary flange
Pos.12	Ventilator door	Pos.23	Mains supply cable with mains connector
		Pos.24	Activated-carbon cassette

2 Preface

One sector of extraction equipment has become very significant in recent years. The filtering of extracted pollutants and the recycling of filtered air to the working area.

This is a surely a sign that the environmental consciousness of every one of us has altered very strongly in favour of our environment. For a long time now, no one has denied that pollution occurs during production. However, the pollutants depend on the process that is used. One can basically distinguish between gases and fumes (smoke). Fumes could also really be described as dust. If you examine this dust under a microscope, you will find that they consist of very fine particles, often with a size of 1 µm or smaller, that can enter the lungs.

The classical method of trying to improve the working conditions of polluted workplaces is general ventilation. In this case, the general rule is a multiple change of air in the workshop, i.e. the complete volume of air in the workshop is replaced. However, this method only achieves a small reduction in the level of pollution within the breathing space of the user.

The same applies to “overhead” extraction, i.e. the installation of large extractor hoods above the workplaces. This is the worst airflow imaginable, since the pollutants first pass through the breathing space of the user, and only afterwards are they contained and extracted. This is surely not the point of the exercise. A much more effective method than overhead/wide-area extraction is the removal of pollutants directly at their source, with localised extraction. Both the investment and the operating costs are much, much lower if localised extraction is used.

The environmental and workplace-safety measures are especially important requirements for successful application of a technology, in addition to the technological optimisation of the processing method. In a time of increasing sensitivity and tougher legislation, the task therefore lies in making an early assessment of the potential hazards for the workplace and the environment, and reducing them as appropriate.

3 Function of the ProtectoSmart

Mobile suction filter ProtectoSmart is best suited to extracting and filtering fumes materialising during the process of spraying within SMART repairs. It is as well suited for absorbing overspray and of solvent & isocyanate fumes and odours emerging from spraying, painting and works with solvent materials. For this purpose, the unit can be equipped with one flexible extractor arm or application-specific fittings.

Limits of application:

Solvent & Isocyanate vapours.

(If you are uncertain, please contact the manufacturer!)

The polluted air is sucked into the extractor hood (or application-specific fitting) and transported through the extractor arm (or extractor hose) to the filter unit. Here, the coarse dust particles are collected in the pre-filter mat (Pos.13). Subsequently the air is lead through the additional filtering mats to the particle filter (Pos.14) which traps extremely fine dust particles with an efficiency of more than 99%. Then the filtered air passes through the activated carbon cassette as a last filter stage where the gases and odours will be refined. Then the air is sucked in by the ventilator and recycled to the air in the workshop through the exhaust grid at the back of the unit.

Caution:

As soon as the resistance to the air flow from the accumulated dust particles on the filter cartridge markedly effects the suction performance, the filter elements shall be exchanged.

(refer to chapter 7.1: "Changing of pre-filter mat", chapter 7.2: "Change of particle filter")

4 Safety instructions

When using electrical equipment, the following basic safety rules must be observed, for protection against electric shock, injury, or fire hazards.

- Before using the equipment, read and observe these instructions!
- Keep the operating and maintenance instructions in a safe place!

Never use the equipment to extract easily inflammable or explosive gases! (Other than specified use)

- Never use the equipment for the extraction of corrosive substances!
- Never use the equipment for the extraction of burning or glowing material!
- Never use the equipment to suck up any kind of liquid!
- Do not use the equipment for the extraction of organic substances without written approval from the manufacturer!
- Protect the connectors from heat, moisture, oil, and sharp edges!
- Keep to the permitted supply voltage!
- Use only Weldability replacement parts!

- Do not operate the equipment without a filter insert!
- Disconnect the supply voltage before opening the filter unit!
- The exhaust vent must not be covered up or blocked!
Always take care that the unit is standing in a stable position, and that the brakes on the castors are on!
- The filter unit must be disconnected from the mains supply voltage before cleaning or maintenance, replacing parts, or a functional conversion!
- The filter inserts cannot be regenerated!
- Dispose of the filter inserts in accordance with the regulations!
- If an energy-saving automatic start/stop is being used, the earthing cable must be checked for possible damage before every welding session.
- The unit must not be used if the earthing cable is not in perfect condition.
- If external filter controls are used, the control cable must be checked for possible damage before every operating session.
- The unit must not be used if the control cable is not in perfect condition!
- The mains supply cable for the unit must be checked regularly for possible damage!
- The unit must not be used if the mains supply cable is not in perfect condition!
- Do not use the filter unit if one or more of its components are faulty, missing, or damaged. In any of these cases, please call the Weldability Service Department: Phone: +44 (0) 845 862 2620.
- When extracting carcinogenic welding fumes as from the processing of nickel or chrome alloys, the requirements of the directives on clean air of the German TRGS 560 'Return of process air when working with carcinogenic media' must be observed. (And/or the equivalent national directives for the respective user.)

5 Commissioning

The filter unit is supplied with all connections.

The extractor fittings and possibly other accessory equipment must be installed or mounted on the unit before commissioning.

5.1 Attaching the extractor fittings

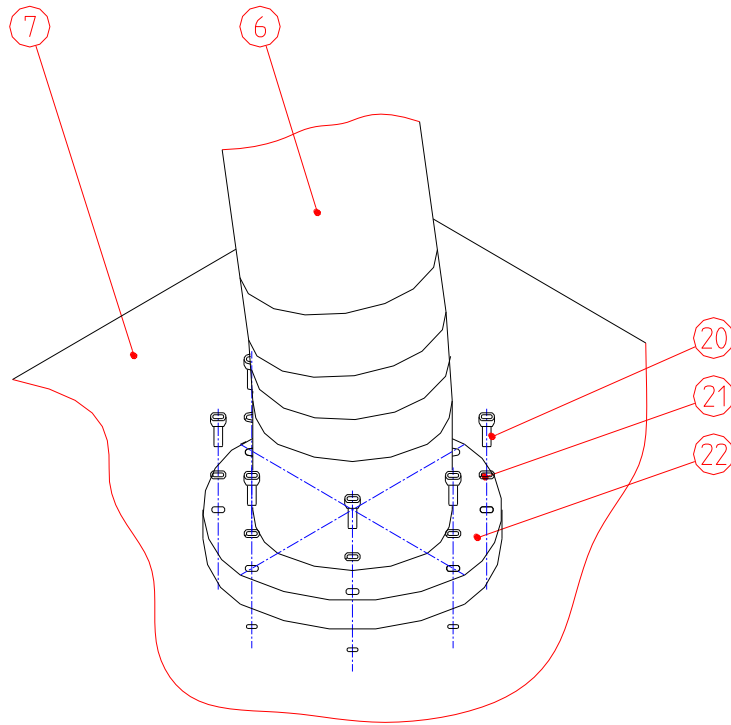

The extractor fitting (e.g. an extractor hose or an extractor arm) must be mounted on the extractor spouts or the housing cover.

If an extractor arm is used, it is attached by using the flange ring (Pos.22), bolts (Pos.20) and washers (Pos.21) that are provided.

Warning:

Please take care that the spout is now able to rotate.

5.2 Electrical connection of the unit

- Connect the filter unit to the mains supply.

Warning:

Work on the electrical sections must only be carried out by qualified and authorized personnel.

5.3 Connection of an air outlet pipe

The filter device ProtectoSmart is primarily used for applications with separate exhaust air. To ensure this functionality, an exhaust pipe must be connected on the air outlet grille on the back of the fan housing (Pos.11).

6 Explanation of the controls

- Pos.1 The main switch switches the filter unit on or off.
- Pos.2 The operating hour counter starts to count as soon as the filter unit will be switch on.
- Pos.3 The operating status lamp shows if the filter unit will be switch on.
- Pos.4 The indicator lamp for flow volume shows whether the suction power is adequate. If it lights up, the filter inserts must be replaced.

7 Maintenance

The accumulation of extracted particles on the filter cartridge will eventually lead to a reduction of the suction / extraction performance.

The mechanical filter element ensures that more than 99% of the extracted pollutants are retained in the filter. This also applies to a partially or fully saturated filter. However, the extraction performance of the filter unit will decrease as the filter elements becomes saturated more and more.

The pre-filter (Pos.14) must be changed at regular intervals. (Refer to chapter 7.1 'Changing of pre-filter element')

When the internal resistance of the filter element has increased due to the accumulation of the separated dust particles and the extraction performance of the filter unit decreases as a whole, the particle filter (Pos. 15) must be changed. (Refer to chapter 7.2 'Changing of particle filter element')

As soon as odours appear the activated-carbon cassette (Pos.24) has to be changed.

Caution :

When changing the filter cartridge, the operation of the filter unit must be interrupted.

Exchange of the filter cartridge and the disposal of the element may be executed only in amply ventilated environments and when using an appropriate protective respiratory mask.

We recommend to use a respiratory mask to DIN EN 141/143 - Protection class P3.

The job of changing the filter elements should be executed by trained personnel only. Filter disposal according to pertinent directives on special waste handling.

Manually beating the filter element, washing or air jet blasting will destroy the filter media. As a result the pollutants will be blown into the room.

7.1 Changing of pre-filter

The pre-filter mat (Pos.14) must be changed after a certain number of operating hours. The time depends on the amount of accumulated dust. At the latest, the filter mat must be changed when changing the particle filter.

The procedure is a follows:

- Disconnect the filter unit from the mains power supply.
- Open the air filter access door (Pos.10).
- Lower the lifting mechanism (Pos.16) by turning the lock screw (Pos.17) downward..
- Pull out the pre-filter tray (Pos.13).
- Take out the pre-filter mat (Pos.14).
- Install the new pre-filter mat.

Caution

Only use original Weldability pre-filter elements.

- Insert the pre-filter tray (Pos.13).
Raise the lifting mechanism (Pos.16) by turning the locking screw (Pos.17) until the pre-filter tray (Pos.13) sits tight. (At this time check the sealing gasket under the lid (Pos.7) for possible damage.
- Close the filter access door (Pos.10).
- Connect the filter unit to the mains circuit.

7.2 Changing of particle filter

When the extraction performance decreases, the particle filter must be changed according to the following procedure:

- Disconnect the filter unit from the mains power supply..
- Open the filter access door (Pos.10).
- Lower the lifting mechanism (Pos.16) by turning the locking screw (Pos.17) downward..
- Pull out the particle filter (Pos.15).
- Install the new particle filter element

Caution

Only use original Weldability particle filter elements.

- Raise the lifting mechanism (Pos.16) by turning the locking screw (Pos.17) until the pre-filter tray (Pos.13) sits tight. (At this time check the sealing gasket under the lid (Pos.7) for possible damage.
- Close the filter access door (Pos.10).
- Connect the filter unit to the mains circuit.

7.3 Changing of the activated-carbon cassette

As soon as odours appear the activated-carbon cassette (Pos.24) has to be changed:

- Disconnect the filter unit from the mains power supply..
- Open the filter access door (Pos.10).
- Lower the lifting mechanism (Pos.16) by turning the locking screw (Pos.17) downward..
- Pull out the activated-carbon cassette (Pos.24).
- Install the new activated-carbon cassette.

Caution: Only use original Weldability particle filter elements!

- Raise the lifting mechanism (Pos.16) by turning the locking screw (Pos.17) until the pre-filter tray (Pos.13) sits tight. (At this time check the sealing gasket under the lid (Pos.7) for possible damage.
- Close the filter access door (Pos.10).
- Connect the filter unit to the mains circuit.

8 Disposal

To ensure perfect operation of your Weldability ProtectoSmart extractor unit and proper disposal of the dust that has been extracted, we offer the following services:

- Help with finding a waste disposal company in your vicinity.
- On request, we can supply a list of all waste disposal companies in Germany, free of charge.
- A service and maintenance contract.
- A customer help line.

Call our service department for these options:

Telephone: +44 (0) 845 862 2620

Fax: +44 (0) 800 970 7757

9 Technical data

Filter unit		ProtectoSmart
Supply voltage	V	230
Current type	Ph	1
Frequency	Hz	50
Motor power	kW	1,1
Max. airflow volume	m³/h	2200
Max. vacuum	Pa	2500
Enclosure type		IP 54
ISO class		F
Operating voltage	V	24
Duty cycle	%	100
Width x depth x height	mm	665 x 681 x 1200
Weight, without arm	kg	95
Filter insert		pre filter, particle filter, activated-carbon cassette
Filter performance	%	>99
Noise level <small>(measured as per DIN 45635 T1: in free air at 1m distance from the surface of the machine, max. airflow volume.</small>	dB(A)	70

10 Parts list

Designation:	Article no.
pre filter (Pos.14)	10032
particle filter H13 (Pos.15), 610x610x186	100357
activated-carbon cassette (Pos.24)	97053

11 Declaration of conformity Weldability - ProtectoSmart

Weldability sif

Peters House, The Orbital Centre
Ickniel Way, Letchworth Garden City
Hertfordshire
SG6 1ET

Tel.: +44 (0) 845 862 2620

Fax: +44 (0) 800 970 7757

E-Mail: sales@weldability-sif.com

www.weldability-sif.com

We herewith declare in sole responsibility that the before mentioned product, starting from machine No.: 10000010011001, conforms to the following standards:

Directives on machine building:	2006/42/EG
Electromagnetic compatibility:	2004/108/EG
Directives on printing device:	97/23/EG
Directives on low voltage:	2006/95/EG

Applied harmonised standards:

- DIN EN 349
- DIN EN ISO 4414
- DIN EN 12100: 2010
- DIN EN 60204 part 1
- DIN EN ISO 13857
- DIN EN ISO 14121

plus further national standards and specifications:

- DIN 45635 part 1

This declaration will become void if changes are effected to the suction and filter systems which were not agreed upon in writing by the manufacturer.

Authorised representative for technical documentation: Technical department, Weldability