

# Extractability™



[www.extractability.co.uk](http://www.extractability.co.uk)

Peters House  
The Orbital Centre  
Icknield Way  
Letchworth Garden City  
Hertfordshire  
SG6 1ET  
Tel. +44 (0) 845 862 2620



## ProtectoXtra 110/230v

CE  
Approved

## Operation Manual

V1. 2019

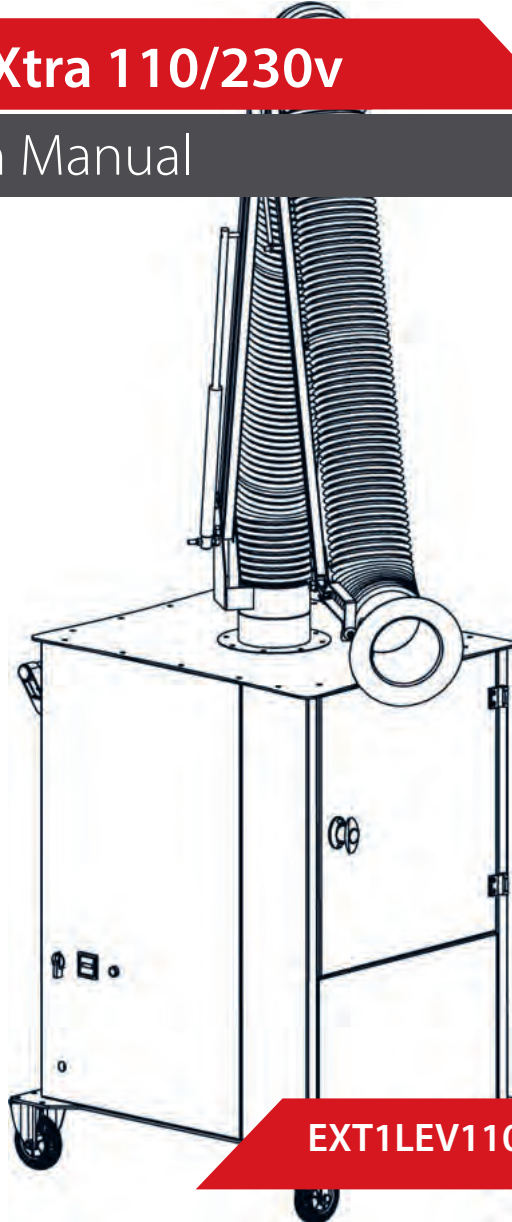

EXT1LEV110/EXT1LEV230

# Contents

1.	Preface	3
1.1	General	3
1.2	Application	4
1.3	Replacement Parts	4
1.4	Product Overview	5
1.5	Technical Specifications	6
2.	Safety Instructions	7
2.1	General	7
2.2	Instructions	8
3.	Installation	9
3.1	Connecting Extraction Elements	9
3.2	Operational Checklist	10
4.	Maintenance.	
4.1	Manual Filter Cleaning	11
4.2	Dust Disposal	11
4.3	Filter Removal	12
4.4	Replacing the Filter	12
5.	Troubleshooting	13
5.1	Diassembly and Disposal	14
6	Declaration of Conformity	15

## Original instruction

All rights reserved. The information given in this document has been collected for the general convenience of our clients. It has been based on general data pertaining to construction material properties and working methods known to us at the time of issue of the document and is therefore subject at any time to change or amendment and the right to change or amend is hereby expressly reserved. The instructions in this publication only serve as a guideline for installation, use, maintenance and repair of the product mentioned on the cover page of this document. This publication is to be used for the standard model of the product of the type given on the cover page. Thus the manufacturer cannot be held responsible for any damage resulting from the application of this publication to the version actually delivered to you. This publication has been written with great care. However, the manufacturer cannot be held responsible, either for any errors occurring in this publication or for their consequences.

# 1. Preface

## 1.1 General

Extraction units have become more and more important, especially the filtration of extracted pollutants and the return of filtered air into the working space.

This certainly shows that the environmental awareness of the individual has strongly developed in a positive way since the fact that production (e.g. welding) generates harmful fumes in the direction of the individual. The types of pollutants however depend on the applied procedure. Generally, you distinguish gases from fumes. Fumes are also known as dusts. If you examine the dust with a microscope, you will discover that they consist of tiny breathable particles 0,001 mm or even smaller in size.

The conventional attempt to improve working conditions within polluted work places is general ventilation. This procedure is based on a multiple exchange of air in the production hall, in other words the contaminated air is renewed. Nevertheless, this method only reduces the concentration of pollutants in the respiration zone of the user to a minimal extent.

This also applies to overhead extraction, i.e. the installation of huge extraction hoods above work places. Pollutants can pass into the breathing zone of the user before they rise up and are captured. This certainly is not the in-tended effect. More efficient than room exhausting or overhead extraction, is the elimination of pollutants directly where they are generated by using local extraction. The investment as well as the operating expenses are typically much lower.

## 1.2 Application

ProtectoXtra mobile extraction system for filtration of particulate fumes and dust. The ProtectoXtra incorporates a cleanable, reusable PTFE cartridge filter for improved economic operations.

The ProtectoXtra is supplied with a 3 metre extraction arm, hose with external joints and provides air movement of 1200 m<sup>3</sup>/h. The PTFE cartridge filter comes already installed. The ProtectoXtra is a mobile unit, weighing 170kg and is supplied on swivel casters for manoeuvrability.

Prohibition of application:

The W3 compliant ProtectoXtra should not be used for filtering fumes that contain oil, solvents, explosive dusts/gasses or hybrid mixtures of wastes.

(In case of doubt, please contact the manufacturer)

The polluted air collected by extraction arms and enters the filter unit through the dirty air inlet. Dust-laden polluted air strikes the impact plate at the inlet and prevents burrs and sparks from entering the filters directly, which could damage the filter. Heavy particles then fall directly into the dust collection drawer. Dirty air is filtered by the filter cartridge and expels clean air back to the atmosphere with the radial fan.

## 1.3 Replacement Parts

Filter Element	Part Number
Cartridge	EXTLEVCART
Replacement Hose (10m)	EXTPVC160
Replacement Hood	EXTLEVHOOD

## 1.4 Product Overview

The ProtectoXtra consists of the following main components and elements:

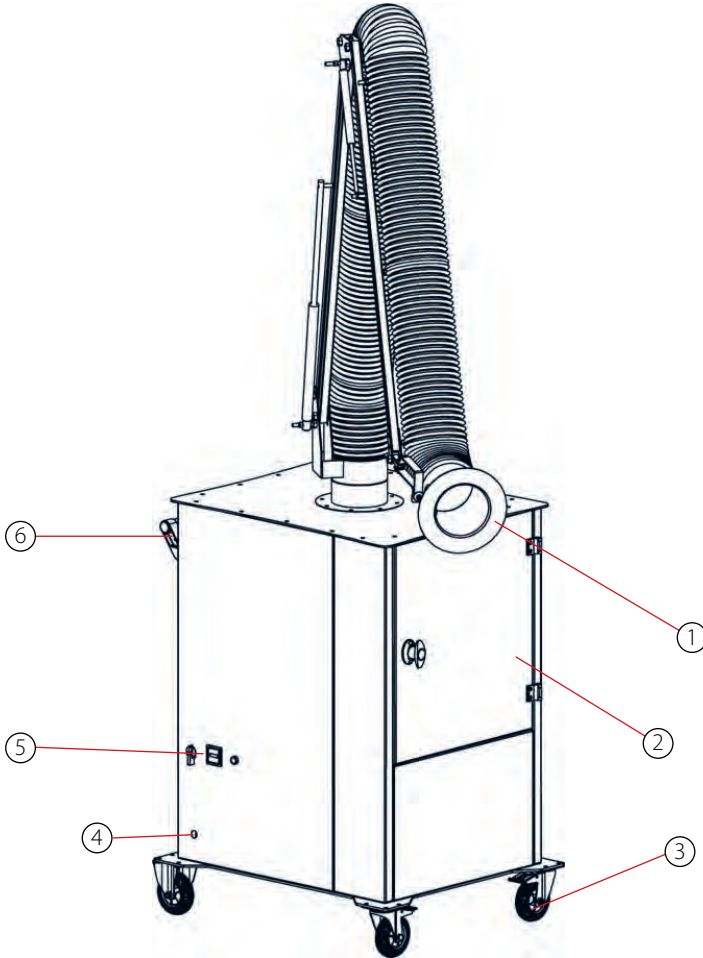

1. Extraction arm (outer support)

2. Filter access door

3. Wheels

4. Mains cable including mains plug

5. Control panel

6. Handle

## 1.5 Technical Specifications

<b>ProtectoXtra</b>	<b>110v/230v</b>
Supply voltage (V)	110/230
Motor power (kW-rpm)	1.1KW-2,950 rpm
Fan capacity (m <sup>3</sup> /h)	2,220
Suction capacity (m <sup>3</sup> /h)	1,220
Fan pressure (pa)	1,500
Max operating temp (°C)	80
Cartridge filter quantity	1
Total filtration area (m <sup>2</sup> )	10
Filtration efficiency	Up to 99.9% @ 0.2-2µ H13/H14
Control voltage (V)	230 115
Extraction arm dimensions	ø160-3m x 1pcs
Width x Depth x Height (without arm) (mm)	660 x 805 x 1170
Weight (without arm) (kg)	170
Filter elements	Cleanable 100% ployester PTFE
Extraction performance (%)	>99
Sound pressure level. (measured according to DIN 45635 T1 at a distance of 1m from the surface of the machine in the free field at a maximal volumetric flow) (dB(A))	74

## 2. Safety Instructions

### 2.1 General

The manufacturer does not accept any liability for damage to the product or personal injury caused by ignoring the safety instructions in this manual, or by negligence during installation, use, maintenance, and repair of the product mentioned on the cover of this document and any corresponding accessories.

Specific working conditions or used accessories may require additional safety instructions. Immediately contact your supplier if you detect a potential danger when using the product.

**The user of the product is always fully responsible for observing the local safety instructions and regulations. Observe all applicable safety instructions and regulations.**

- Everyone working on or with the product must be familiar with the contents of this manual and must strictly observe the instructions there in.
- The management should instruct the personnel in accordance with the manual and observe all instructions and directions given.
- Never change the order of the steps to perform. Always keep the manual with the product
- The pictogram, warning and instructions attached to the product are part of the safety features. They must not be covered or removed and must be present and legible during the entire life of the product
- Immediately replace or repair damaged or illegible pictogram, warnings and instructions

The product has been designed exclusively for extracting and filtering gases and particles which are released during the most common welding processes. Using the product for other purposes is considered contrary to its intended use. The manufacturer accepts no liability for any damage or injury resulting from such use. The product has been built in accordance with state-of-the-art standards and recognised safety regulations. Only use this product when in technically perfect condition in accordance with its intended use and the instructions explained in the user manual.

## 2.2 Instructions

When handling electrical appliances, the following general safety measures must be taken for the protection against electric shocks, risk of injury and fire:

- Read and observe these instructions before using the device
- Keep this operating and maintenance manual in a safe place
- Do not use the device to extract easily inflammable or explosive gases
- Do not use the device in explosive zones
- Do not use the device to extract burning or glowing materials, e.g. cigarettes, matches, metallic dusts, as well as splinters, paper, cleaning cloths etc.
- Do not use the device to extract burning or inflammable materials, e.g. oil or oil mist, greases, release agents (e.g. silicone spray), cleaning agents, etc.
- Do not use the device to extract aggressive media
- Do not use the device to extract liquids of all kinds.
- Do not use the device to extract organic materials without a written authorization of the manufacturer.
- Protect the connecting plug from heat, humidity, oil and sharp edges.
- Observe the approved supply voltage. (Observe the indications on the nameplate)
- Only use Weldability spare parts.
- Do not use the device without filter elements.
- Ensure the appropriate Filters are suitable for the intended application and are installed before use. See section 4.6 for further information on the additional optional filters and their function.
- Before opening the device, separate it from the mains supply.
- The outlet holes must not be covered or blocked.
- Always take care that the device is in a safe position and that the brakes at the swivel castors are pulled.
- When cleaning and maintaining the device, replacing parts or when changing to another function. Disconnect the filter unit from the mains supply.
- The filter elements must not be reused.
- Dispose of the filter cartridges according to the legal regulations.
- The device must not be used if the mains cable is not in perfect condition
- The suction hood must be followed the progression of the weld seam, if possible in exploiting the thermal movements of the welding fume.
- The maximum admissible distance between the extraction element and the welding point should not exceed 25 cm.
- Do not use the filter unit if one or more parts of the unit are faulty, missing or damaged. In each of these cases, please contact the Weldability service department on +44 (0) 845 862 2620.
- When extracting carcinogenic fumes, e.g. materials containing nickel or chrome, the ventilation requirements have to be observed
- During transport, the device has to be secured against falling and slipping.
- When lifting and putting down the device, do not remain below or next to the load.



## 3. Installation

The filter unit is delivered completely assembled. The extraction element (suction arm or suction hose) is separately packed. The extraction element must be connected to the device before commissioning.

### 3.1 Connecting the Extraction Elements

#### Extraction Arm Installation

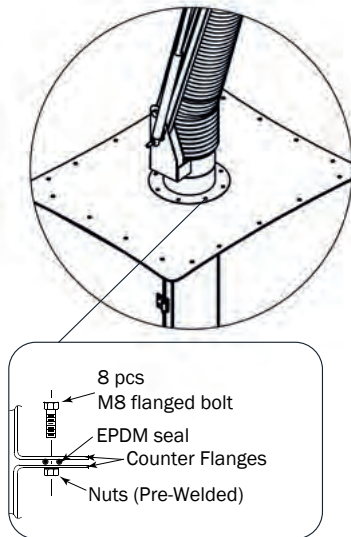

#### Wheel Installation (already attached)

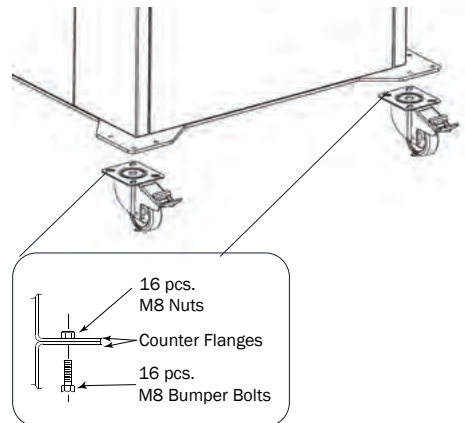

#### Attention:

Take care that the flange must be pivotal.

1. Bring the swivel flange of the extraction arms onto the device and fix it with bolts.
2. Tighten all bolts securely. Make sure they are tighten properly.

#### Attention:

Installation requires a minimum of two people and lifting equipment.

1. Lift the filter unit off the ground
2. Tighten all bolts securely. Make sure it is tighten properly.

## 3.2 Operational Checklist

1. Monitor the physical condition of the filter unit and repair or replace damaged components.

Routine inspections will minimise downtime and maintain optimum system performance. This is particularly important for continuous dust collecting systems.

2. Please check if filter clog alarm is ON. If the alarm illuminates, clean the filter manually with dry compressed air (max. 6 bar). If the alarm continues after cleaning, you need to then replace the filter with a new one.

3. Check regularly for the presence of dust in the fan section.



**Do not position the machine in places where it is exposed to vibrations or radiation from heat sources. Observe the ambient conditions first.**



**Always use the product in an upright position. Make sure that the inlet is closed when transporting the product over large distances.**



**Never use the machine without full filter package.**

## 4. Maintenance

Information for all staff operating and maintaining the ProtectXtra

Use the recommended equipment for maintaining the extraction unit and all safety precautions (including work gloves, masks etc.) should be adhered to before maintenance.

Use proper access equipments and procedure

Electrical service or maintenance work must be performed by a qualified electrician and comply with all safety procedures.

Turn power off all power before performing any service or maintenance work. Also wait until the impeller(rotor) rotation to stop before starting any service or maintenance work.



**Overdue maintenance can cause fire. Always fully disconnect the machine from the mains before carrying out maintenance jobs of mentioned in the following section.**

## 4.1 Manual Filter Cleaning

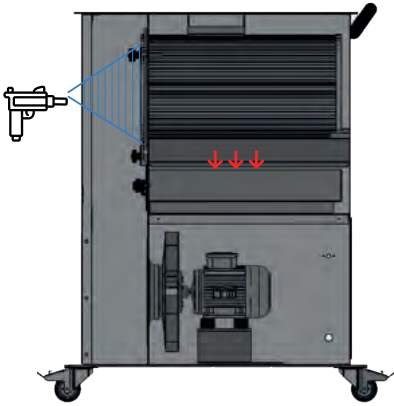

**Be extremely careful** when operating a compressed air gun. It should be used by authorised and trained personnel. Ensure operator is wearing correct PPE/RPE to protect the respiratory tract and skin.

- Open the filter cartridge access door.
- Apply the 6 bar dry compressed air to the filter cartridge as shown.
- Clean the filter inside and out thoroughly.
- Wait for 5 minutes for the dust to settle and accumulate in the dust drawer.
- Remove the dust drawer and dispose of the waste using the correct regulations.

## 4.2 Dust Disposal



**Be extremely careful** when disposing of the dust which should be done by authorised and trained personnel. Ensure operator is wearing correct PPE/RPE to protect the respiratory tract and skin.

- Disconnect the filter unit from the mains supply
- Hazardous dust may be exposed when removing the filters. Use appropriate safety and protective equipment. (Protective masks, gloves etc.)
- The full dust drawers may be heavier than they appear.
- To avoid personal injury and / or property damage, take care when removing the dust drawer.
- Turn off any power before performing any service or maintenance work. Also wait until motor impeller (rotor) stop completely.
- Do not operate with missing or damaged filters.
- Unscrew and remove the fitting component as shown in the illustration
- Carefully pull the drawer towards you using the drawer handle and pull it out the slot.

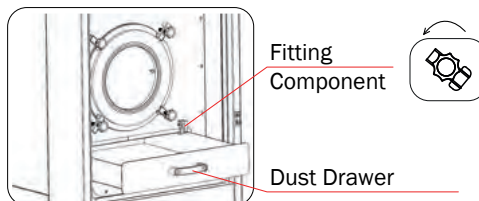

## 4.3 Filter Removal

- Hazardous dust may be exposed when removing the filter. Use appropriate safety and protective equipment such as protective mask and gloves.
- The dirty filters may be heavier than appear so be extremely careful when removing them.
- Disconnect the filter unit from the mains supply before any service or maintenance takes place.
- Do not operate with missing or damaged filters.

**Attention:**

Only use Extractability filter elements provided by Weldability Sif.

- Extractability use filters especially designed for each extraction unit. Therefore it is essential to use the correct filter for each unit.
- Permanent damage may occur to the extraction unit if an incorrect filter is used and the guarantee will be invalid.

## 4.4 Replacing the Filter

**Attention:**

Only use Extractability filter elements provided by Weldability Sif.



- Open the cartridge filter access door by turning the twist lock as shown.



- Unscrew the fitting component as shown and remove it.

- Remove the cartridge filters straight as shown. When removing the filters, it is recommended to remove them with proper waste bags to avoid any exposure to harmful substances

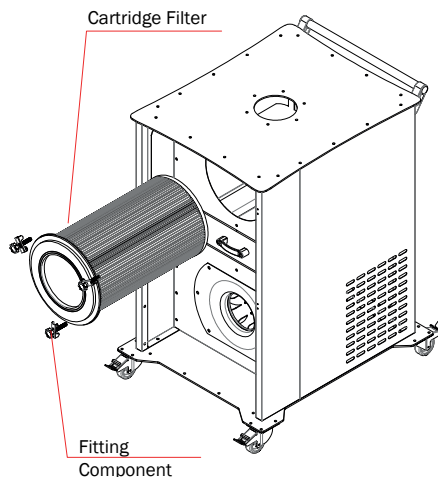

# 5. Troubleshooting

In the event of an incident, disconnect the filter unit from the mains supply as a precaution measure. In case of a potential electrical fault, it is obligatory to consult an electrician.



**Always disconnect the machine from the mains before carrying out the activities below.**

Fault found	Origin	Recommended Repair
Extraction performance is not sufficient (Fumes are not or only hardly extracted)	Filters are saturated	Replace the filters, dispose correctly of the saturated filter!
	Extraction element is damaged	Replace the extraction element.
	Suction arm is not correctly connected	Check the position of the suction arm and connect it if necessary.
	Clean air outlet is narrowed or covered	Check the clean air outlet, repair the fault if necessary.
	Suction duct is narrowed	Check the suction duct, repair the fault if necessary.
Fan blower and motor start, but do not stayrunning	Electrical circuit overload	Check that the power supply circuit has sufficient power to run all equipment.
Clean-air outlet discharging dust.	Filters not installed correctly	
	Filter damage, dents in the end caps, gasket damage, or holes	Replace Cartridge Filters
Insufficient Airflow	Fan rotation backwards	Check the fan rotation direction. If rotating in the opposite direction, replace the two pins on the power supply.
	Extraction arm hose is damaged or leaking	Check extraction arm hose. If there is any damage, replace it with the new one.
	Suction hood manual valve is shut-off	Check the manual valve on the suction hood. If it is shut-off, open.
	Cartridge filters are clogged	Clean the cartridge filters manually. Replace the cartridge filters if the desired air flow is not achieved even after cleaning.
	Clogged fan exhaust holes	Check the fan exhaust holes. If there is any blockage, drill these holes.

<b>Fault found</b>	<b>Origin</b>	<b>Recommended Repair</b>
Dust occur outside of the dust drawer	Dust drawer seals are worn	Replace the seals on the dust drawer
	Fitting component is not aligned properly	Reposition the fitting component properly and tighten it as much as possible.
Alarm goes off indicating the filter is full	Filter cartridges are clogged	Clean filter cartridges manually.
Alarm goes off indicating the filter is full even after manual cleaning	Filter cartridges are totally clogged	Replace the filter cartridge with Extractability recommended filter.

## 5.1 Disassembly and Disposal

- Only qualified electricians may be charged with the disassembly of the machine or the electrical unit, the electrical supply line. Before disassembling the machine, disconnect it from the mains supply.
- Dispose of the pollutants and the filter media correctly and appropriately.
- Observe the indications of the manufacturer or contact the manufacturer.

In order to make sure the correct operation of your filter unit ProtectoXtract as well as an appropriate disposal of the separated dust, we offer you the following services:

- We help you to find a waste disposal company within your reach.
- On demand and free of charge, we provide you a list with all disposal companies in England
- Conclusion of a maintenance and service contract
- A customer help line

For these options, please contact our service department:

Phone: +44 (0) 845 862 2620

## 6. Declaration of Conformity

Weldability Sif  
 Peters House, The Orbital Centre  
 Icknield Way, Letchworth Garden City  
 Hertfordshire  
 SG6 1ET  
 Tel: +44 (0) 845 862 2620  
 Email: sales@weldability-sif.com      www.weldability-sif.com

We hereby declare under our sole responsibility that the product mentioned above, conforms to the following directives:

**Device usage:** Filter unit for local extraction of dust and fumes.

<b>Machinery directive:</b>	2006/42/EG
<b>Electromagnetic compatibility:</b>	2004/108/EG
<b>Pressure equipment device:</b>	97/23/EG
<b>Low voltage directive:</b>	2006/95/EG

This declaration will become void if the suction and filter unit is exposed to modifications that are not approved by the manufacturer in written form.

**Authorised for technical documentation:** Weldability sif

Signature

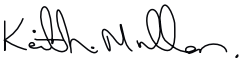

Keith Mullan  
 Quality Manager  
 Weldability Sif



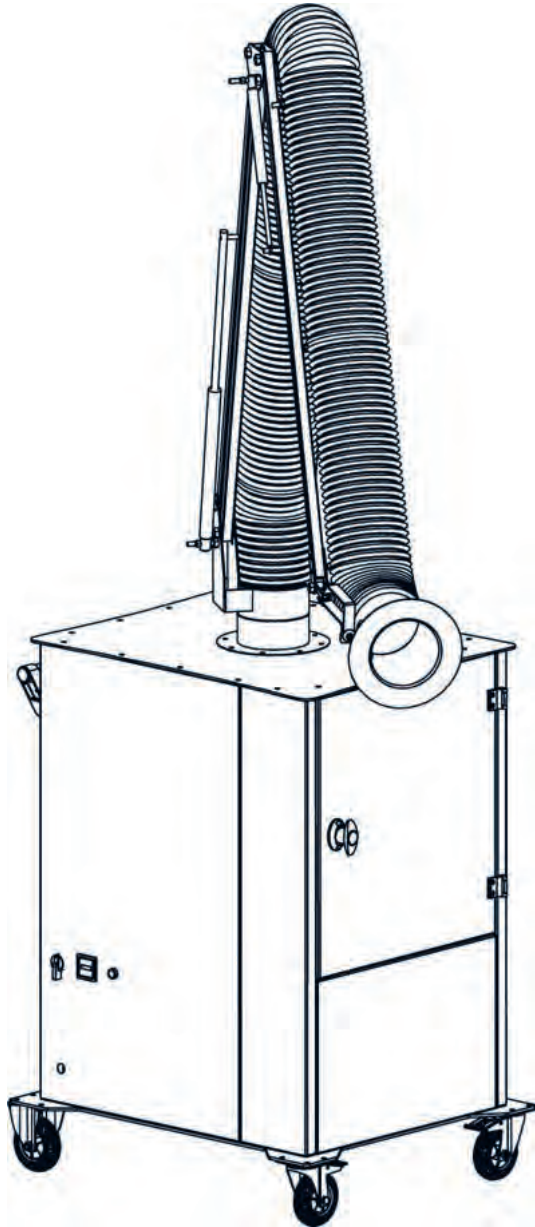

**Weldability** *sif*

Peters House, The Orbital Centre, Icknield Way, Letchworth Garden City, Hertfordshire, SG6 1ET  
Tel. +44 (0) 845 862 2620 | Email. sales@weldability-.com | www.weldability-sif.com