

Rogue EMP 210 PRO

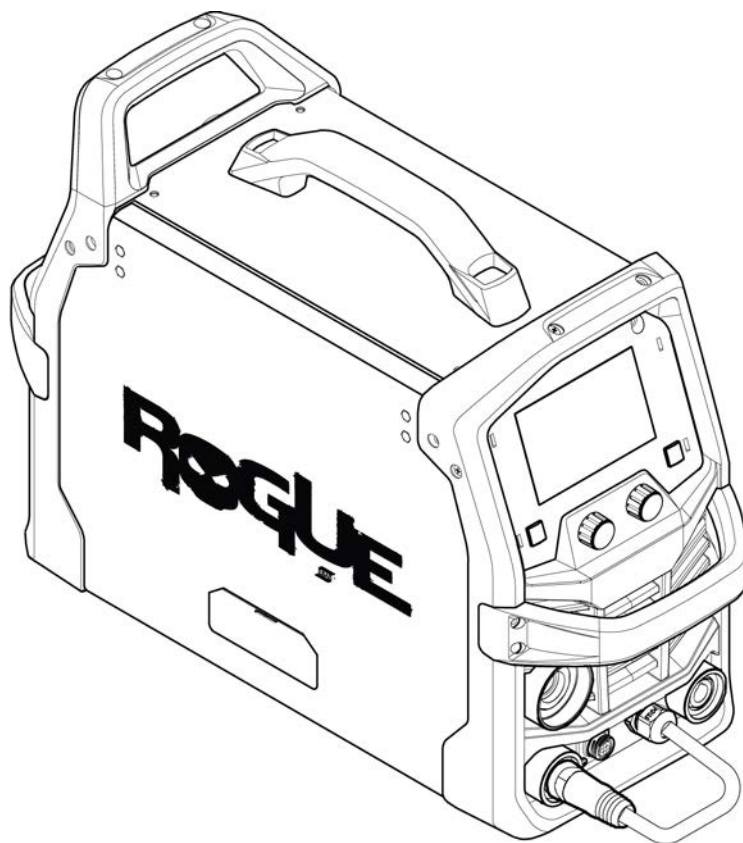

Instruction manual



EU DECLARATION OF CONFORMITY

According to:

The Low Voltage Directive 2014/35/EU; The EMC Directive 2014/30/EU;
The RoHS Directive 2011/65/EU; The Ecodesign Directive 2009/125/EC

Type of equipment

Arc welding power source

Type designation

EMP 210Pro from serial number HG325 YY XX XXXX
X and Y represents digits, 0 to 9 in the serial number, where YY indicates year of production.

Brand name or trademark

ESAB

Manufacturer or his authorised representative established within the EEA

ESAB AB
Lindholmsallén 9, Box 8004, SE-402 77 Göteborg, Sweden
Phone: +46 31 50 90 00, www.esab.com

The following EN standards and regulations in force within the EEA has been used in the design:

EN IEC 60974-1:2018/A1:2019	Arc Welding Equipment - Part 1: Welding power sources
EN IEC 60974-5:2019	Arc welding equipment - Part 5: Wire feeders
EU reg. no. 2019/1784	Ecodesign requirements for welding equipment pursuant to Directive 2009/125/EC
EN 60974-10:2014	Arc Welding Equipment - Part 10: Electromagnetic compatibility (EMC) requirements

Additional Information:

Restrictive use, Class A equipment, intended for use in locations other than residential.
EMP 210Pro is part of ESAB Rogue product family.

By signing this document, the undersigned declares as manufacturer, or the manufacturer's authorised representative established within the EEA, that the equipment in question complies with the safety and environmental requirements stated above.

Place/Date

Signature

Göteborg
2023-06-21

Bartosz Kutarba
Bartosz Kutarba
Global Director Light Industrial Products
Welding and Plasma



TABLE OF CONTENTS

1	SAFETY	4
1.1	Meaning of symbols	4
1.2	Safety precautions	4
2	INTRODUCTION	7
2.1	Equipment	7
3	TECHNICAL DATA	8
4	INSTALLATION	10
4.1	Location	10
4.2	Lifting instruction	10
4.3	Mains supply	11
4.4	Recommended fuse and cable sizes	12
5	OPERATION	13
5.1	Connections	14
5.2	Cable connection - Weld, return and polarity change over	14
5.3	Drive system diagram	15
5.4	Attaching fusion 180 MIG gun	16
5.5	Inserting and replacing wire	16
5.5.1	Welding with aluminium wire	18
5.5.2	Installing 12.5 lb spool (8 in. diameter)	18
5.5.3	Installing 2 lb spool (4 in. diameter)	19
5.6	Setting the wire feed pressure	19
5.7	Changing the feed/pressure rollers	20
5.8	Shielding gas	20
5.9	Duty cycle	21
6	USER INTERFACE	22
6.1	Home screen	22
6.2	Navigation	22
6.3	GMAW Synergic mode	23
6.4	GMAW Manual mode	23
6.5	SMAW (MMA) mode	26
6.6	Live GTAW mode	27
6.7	Icon reference guide	27
7	MAINTENANCE	29
7.1	Routine maintenance	29
7.2	Power source and wire feeder maintenance	31
7.3	Torch and liner maintenance	32
8	ERROR CODES	33
8.1	Error code descriptions	33
9	TROUBLESHOOTING	34
10	ORDERING SPARE PARTS	36
	WIRING DIAGRAM	37
	ORDERING NUMBERS	38
	WEAR PARTS	39
	ACCESSORIES	40

1 SAFETY

1.1 Meaning of symbols

As used throughout this manual: Means Attention! Be Alert!



DANGER!

Means immediate hazards which, if not avoided, will result in immediate, serious personal injury or loss of life.



WARNING!

Means potential hazards which could result in personal injury or loss of life.



CAUTION!

Means hazards which could result in minor personal injury.



WARNING!

Before use, read and understand the instruction manual and follow all labels, employer's safety practices and Safety Data Sheets (SDSs).



1.2 Safety precautions

Users of ESAB equipment have the ultimate responsibility for ensuring that anyone who works on or near the equipment observes all the relevant safety precautions. Safety precautions must meet the requirements that apply to this type of equipment. The following recommendations should be observed in addition to the standard regulations that apply to the workplace.

All work must be carried out by trained personnel well-acquainted with the operation of the equipment. Incorrect operation of the equipment may lead to hazardous situations which can result in injury to the operator and damage to the equipment.

1. Anyone who uses the equipment must be familiar with:
 - its operation
 - location of emergency stops
 - its function
 - relevant safety precautions
 - welding and cutting or other applicable operation of the equipment
2. The operator must ensure that:
 - no unauthorised person is stationed within the working area of the equipment when it is started up
 - no-one is unprotected when the arc is struck or work is started with the equipment
3. The workplace must:
 - be suitable for the purpose
 - be free from drafts
4. Personal safety equipment:
 - Always wear recommended personal safety equipment, such as safety glasses, flame-proof clothing, safety gloves
 - Do not wear loose-fitting items, such as scarves, bracelets, rings, etc., which could become trapped or cause burns
5. General precautions:
 - Make sure the return cable is connected securely
 - Work on high voltage equipment **may only be carried out by a qualified electrician**
 - Appropriate fire extinguishing equipment must be clearly marked and close at hand
 - Lubrication and maintenance must **not** be carried out on the equipment during operation

If equipped with ESAB cooler

Use ESAB approved coolant only. Non-approved coolant might damage the equipment and jeopardize product safety. In case of such damage, all warranty undertakings from ESAB cease to apply.

For ordering information, see the "ACCESSORIES" chapter in the instruction manual.

**WARNING!**

Arc welding and cutting can be injurious to yourself and others. Take precautions when welding and cutting.

**ELECTRIC SHOCK - Can kill**

- Install and ground the unit in accordance with instruction manual.
- Do not touch live electrical parts or electrodes with bare skin, wet gloves or wet clothing.
- Insulate yourself from work and ground.
- Ensure your working position is safe

**ELECTRIC AND MAGNETIC FIELDS - Can be dangerous to health**

- Welders having pacemakers should consult their physician before welding. EMF may interfere with some pacemakers.
- Exposure to EMF may have other health effects which are unknown.
- Welders should use the following procedures to minimize exposure to EMF:
 - Route the electrode and work cables together on the same side of your body. Secure them with tape when possible. Do not place your body between the torch and work cables. Never coil the torch or work cable around your body. Keep welding power source and cables as far away from your body as possible.
 - Connect the work cable to the workpiece as close as possible to the area being welded.

**FUMES AND GASES - Can be dangerous to health**

- Keep your head out of the fumes.
- Use ventilation, extraction at the arc, or both, to take fumes and gases away from your breathing zone and the general area.

**ARC RAYS - Can injure eyes and burn skin**

- Protect your eyes and body. Use the correct welding screen and filter lens and wear protective clothing.
- Protect bystanders with suitable screens or curtains.

**NOISE - Excessive noise can damage hearing**

Protect your ears. Use earmuffs or other hearing protection.

**MOVING PARTS - Can cause injuries**

- Keep all doors, panels and covers closed and securely in place. Have only qualified people remove covers for maintenance and troubleshooting as necessary. Reinstall panels or covers and close doors when service is finished and before starting engine.
- Stop engine before installing or connecting unit.
- Keep hands, hair, loose clothing and tools away from moving parts.

**FIRE HAZARD**

- Sparks (spatter) can cause fire. Make sure that there are no inflammable materials nearby.
- Do not use on closed containers.



HOT SURFACE - Parts can burn

- Do not touch parts bare handed.
- Allow cooling period before working on equipment.
- To handle hot parts, use proper tools and/or insulated welding gloves to prevent burns.

MALFUNCTION - Call for expert assistance in the event of malfunction.

PROTECT YOURSELF AND OTHERS!



CAUTION!

This product is solely intended for arc welding.



WARNING!

Do not use the power source for thawing frozen pipes.



CAUTION!

Class A equipment is not intended for use in residential locations where the electrical power is provided by the public low-voltage supply system. There may be potential difficulties in ensuring electromagnetic compatibility of class A equipment in those locations, due to conducted as well as radiated disturbances.



NOTE!

Dispose of electronic equipment at the recycling facility!

In observance of European Directive 2012/19/EC on Waste Electrical and Electronic Equipment and its implementation in accordance with national law, electrical and/or electronic equipment that has reached the end of its life must be disposed of at a recycling facility.

As the person responsible for the equipment, it is your responsibility to obtain information on approved collection stations.

For further information contact the nearest ESAB dealer.



ESAB has an assortment of welding accessories and personal protection equipment for purchase. For ordering information contact your local ESAB dealer or visit us on our website.

2 INTRODUCTION

The **Rogue EMP 210 PRO** is a self-contained single phase welding system that is capable of performing GMAW (MIG) welding SMAW (STICK) and L-GTAW (LIVE GTAW) welding.

The power source is equipped with an integrated wire feed unit, digital voltage, amperage meters, and a host of other features.

2.1 Equipment

Rogue EMP 210 PRO is supplied with:

- Welding power source
- MXL 201, Euro, 3 m
- Gas hose 4 m
- Work clamp leadset, 3 m, 16 mm², 35–50 OKC
- OK AristoRod 12.50 0.8 mm, 1 kg
- Filler metal, Goldrox, 1 kg, 2.5×350 mm
- Feed roll, 0.6/0.8 mm V
- Feed roll 0.8/1.0 mm V
- Feed roll 1.0/1.2 mm U
- Electrode holder, 3 m, 16 mm², 35–50 OKC
- Safety Instruction

3 TECHNICAL DATA

	Rogue EMP 210 PRO
Outlet voltage	230 V 1~ 50/60 Hz
Primary current	
I_{\max} GMAW - MIG	28 A
I_{\max} GTAW - TIG	21 A
I_{\max} SMAW - MMA	26 A
I_{eff} GMAW - MIG	14 A
I_{eff} GTAW - TIG	10.5 A
I_{eff} SMAW - MMA	13 A
No-load power demand when in energy saving mode	<50 W
Setting range	
GMAW	30 A/15.5 V ~ 210 A/24.5 V
GTAW	10 A/10.4 V ~ 210 A/18.4 V
SMAW	10 A/20.4 V ~ 180 A/27.2 V
Permissible load at GMAW - MIG	
25 % duty cycle	210 A/24.5 V
60 % duty cycle	136 A/20.8 V
100% duty cycle	105 A/19.2 V
Permissible load at GTAW - TIG	
25 % duty cycle	210 A/18.0 V
60 % duty cycle	136 A/15.4 V
100% duty cycle	105 A/14.2 V
Permissible load at SMAW - MMA	
25 % duty cycle	180 A/27.2 V
60 % duty cycle	116 A/24.7 V
100% duty cycle	90 A/23.6 V
Power factor at maximum current	
GMAW	0.99
GTAW	0.99
SMAW	0.99
Efficiency at maximum current	
GMAW	>80 %
GTAW	>80 %
SMAW	>80 %
Open-circuit voltage U_0 max (VRD 35 V deactivated)	78 V
Operating temperature	-10 to +40°C (+14 to 104°F)

	Rogue EMP 210 PRO
Transportation temperature	-20 to +55°C (-4 to +161°F)
Constant sound pressure when idling	<70 db
Wire feed speed range	2-16.5 mpm (75-650 ipm)
Bobbin size	100 mm (4 in.) 200 mm (8 in.)
Wire diameter	GMAW: 0.6-1.0 mm (0.023-0.040 in.) FCAW: 0.8-1.2 mm (0.030-0.045 in.)
Maximum material thickness	GMAW/Flux-cored: Steel: 0.5-10.0 mm (24 ga.-3/8 in.) Aluminium: 1.2-10.0 mm (18 ga.-3/8 in.) Stainless: 0.8-10.0 mm (22 ga.-3/8 in.) GTAW: 0.6-5.0 mm (22 ga.-3/16 in.) SMAW: 1.3-10.0 mm (16 ga.-3/8 in.)
Dimensions l × w × h	590 × 220 × 385 mm (23.2 × 8.7 × 15.2 in.)
Weight	16.7 kg (36.7 lbs)
Enclosure class	IP 23S
Application class	S

Duty cycle

The duty cycle refers to the time as a percentage of a ten-minute period that you can weld or cut at a certain load without overloading. The duty cycle is valid for 40 °C / 104 °F, or below.

Enclosure class

The **IP** code indicates the enclosure class, i.e. the degree of protection against penetration by solid objects or water.

Equipment marked **IP23S** is intended for indoor and outdoor use; however, should not be operated in precipitation.

Application class

The symbol **S** indicates that the power source is designed for use in areas with increased electrical hazard.

VRD (Voltage reducing device)

The VRD function ensures that the open-circuit voltage does not exceed 35 V when welding is not being carried out. The VRD function must be activated by a qualified service technician.

4 INSTALLATION

The installation must be carried out by a professional.



CAUTION!

This product is intended for industrial use. In a domestic environment this product may cause radio interference. It is the user's responsibility to take adequate precautions.



CAUTION!

Remove any packaging material prior to use. Do not block the air vents at the front or rear of the welding power source.

4.1 Location

Position the power source so that cooling air inlets and outlets are not obstructed.

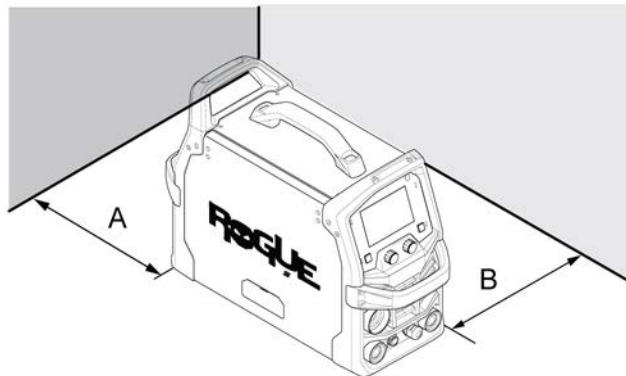

A. Minimum 200 mm (8 in.)

B. Minimum 200 mm (8 in.)

4.2 Lifting instruction

The power source can be lifted using any of the handles.

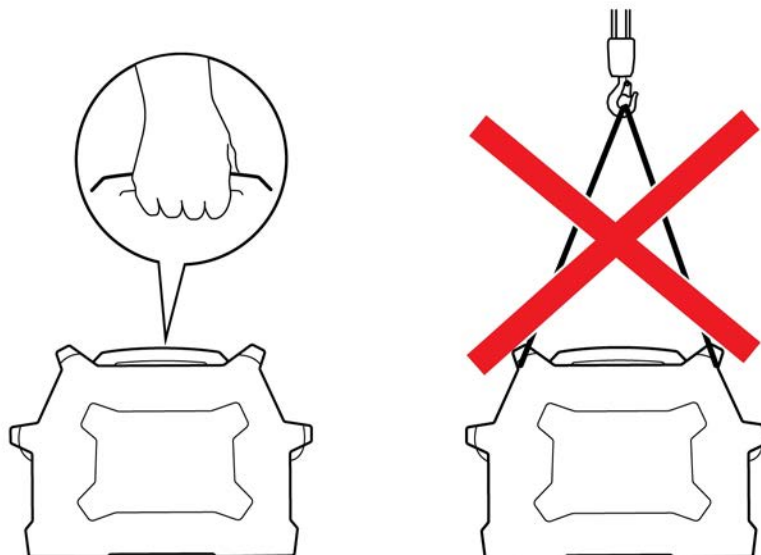

**WARNING!**

Secure the equipment - particularly if the ground is uneven or sloping.

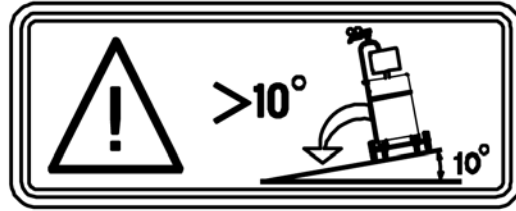

4.3 Mains supply

The supply voltage should be 230 V AC $\pm 15\%$ or 120 V $\pm 15\%$. Too low supply voltage may cause poor welding performance. Too high welding supply voltage will cause components to overheat and possibly fail. Contact the local electric utility for information about the type of electrical service available, how proper connections should be made, and inspection required.

The welding power source must be:

- Correctly installed, if necessary, by a qualified electrician.
- Correctly earthed (electrically) in accordance with local regulations.
- Connected to the correct size power point and fuse as table below.

**NOTE!**

Use the welding power source in accordance with the relevant local and national regulations.

**CAUTION!**

Disconnect input power and secure employing 'Lock-out' / 'Tagging' procedures. Ensure input power line disconnect switch is locked (lock-out/Tagging) in the 'Open' position BEFORE removing input power fuses. Connection/Disconnect should be carried out by competent persons.

1. Rating plate

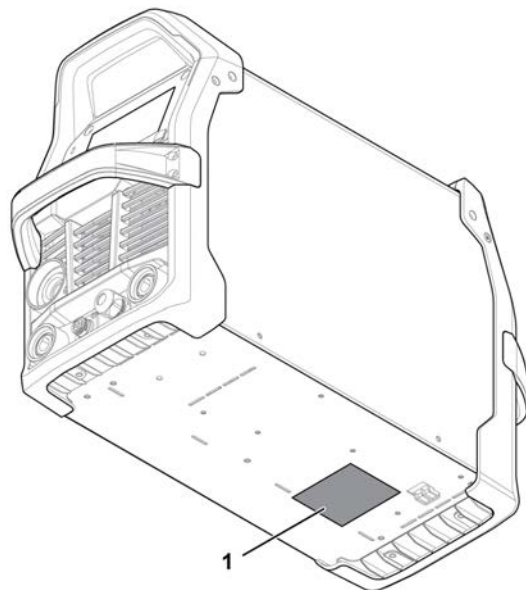

4.4 Recommended fuse and cable sizes



WARNING!

An electrical shock or fire hazard is probable if the following electrical service guide recommendations are not followed. These recommendations are for a dedicated branch circuit sized for the rated output and duty cycle of the welding power source

Supply voltage	230 V AC, 1~50/60 Hz
	230 V AC
Input current at maximum output	28 A
Maximum recommended fuse* or circuit breaker rating * Time delay fuse	25 A
Maximum recommended fuse of circuit breaker rating	32.0 A
Minimum recommended cord size	2.08 mm ² (14 AWG)
Maximum recommended extension cord length	100 m (325 ft.)
Minimum recommended grounding conductor size	2.08 mm ² (14 AWG)

Supply from power generators

The power source can be supplied from different types of generators. However, some generators may not provide sufficient power for the welding power source to operate correctly. Generators with Automatic Voltage Regulation (AVR) or with equivalent or better type of regulation, with rated power 9 kW, are recommended.

5 OPERATION

General safety regulations for handling the equipment can be found in the "SAFETY" chapter of this manual. Read it through before you start using the equipment!



NOTE!

When moving the equipment use intended handle. Never pull the cables.



WARNING!

Rotating parts can cause injury, take great care.



WARNING!

Electric shock! Do not touch the workpiece or the welding head during operation!



WARNING!

Assure that the side panels are closed during operation.



WARNING!

Tighten the bobbin locking nut in order to prevent it from sliding off the hub.

5.1 Connections

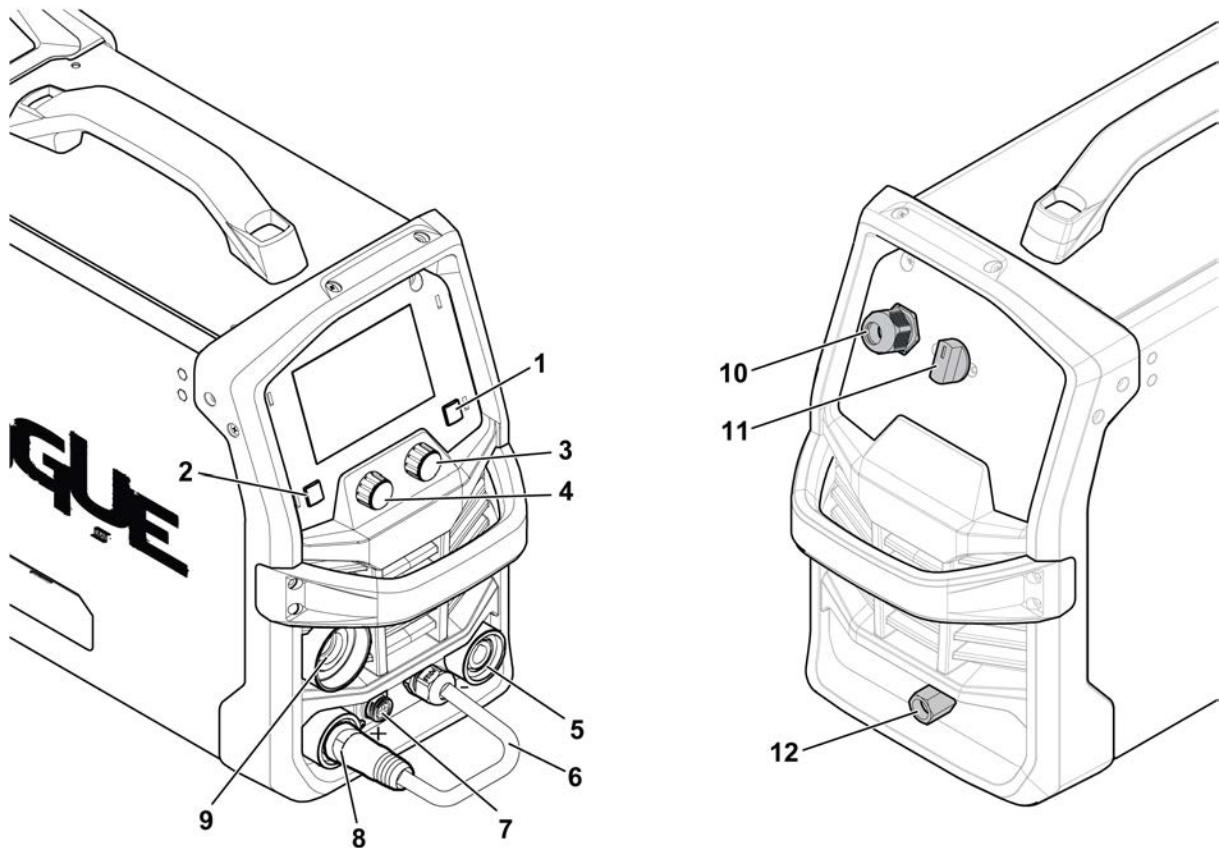

- | | |
|--|---|
| 1. Push button (menu access) | 7. Torch trigger and spool gun control receptable |
| 2. Push button (return to previous menu) | 8. Electrode positive terminal (+) |
| 3. Push button encoder (parameter adjust and display navigation) | 9. GMAW torch and spool gun connection |
| 4. Encoder (parameter adjust) | 10. Mains supply cable |
| 5. Electrode negative terminal (-) | 11. Mains supply switch, ON/OFF |
| 6. Polarity changeover cable | 12. Gas inlet |

5.2 Cable connection - Weld, return and polarity change over

The power source has two output studs for connecting the weld and return cables: Electrode negative [-] terminal (5) and Electrode positive [+] terminal (8), see Section 5.1 "Connections", page 14.

GMAW Synergic & Manual mode - solid wires **GMAW Synergic & Manual mode - FCAW wires**

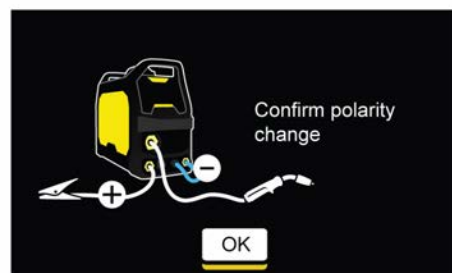
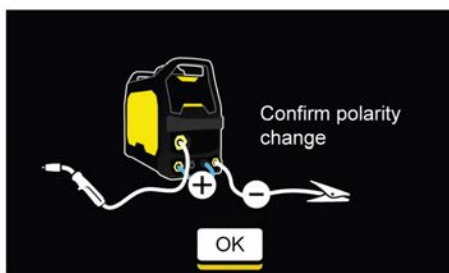

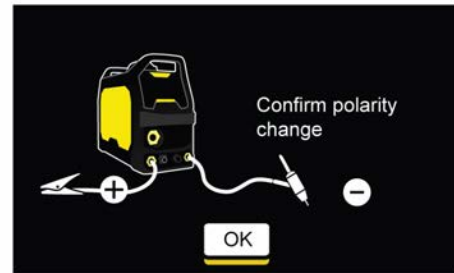
Stick (SMAW)**Live GTAW**

The polarity changeover cable is used to select the correct polarity for the weld output. The correct polarity is determined by the wire that has been selected to complete the weld. To configure the machine to operate with electrode positive insert and secure the polarity changeover cable into the positive [+] terminal and the return lead into the negative [-] terminal. Be sure that the connections are tight. Secure the work clamp to the work piece in a clean, debris free location.

Secure the work clamp to the work piece in a clean, debris free location.

**NOTE!**

Some wires it is recommended to use negative polarity such as self-shielded flux-core. See wire manufacturers recommendation.

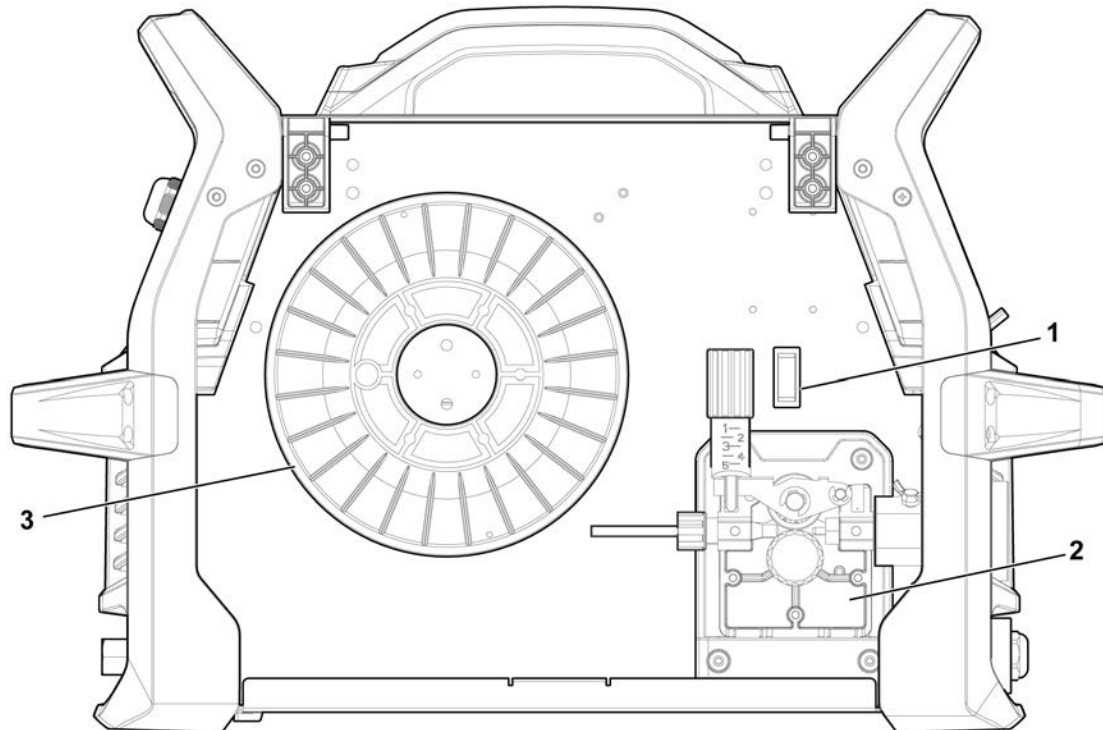
5.3 Drive system diagram

1. Wire inching/purge
2. Wire feed mechanism

3. Wire spool

5.4 Attaching fusion 180 MIG gun

Direct plug MIG guns install by inserting the power pin of the torch into the torch receptacle located on the front of the unit and tightening the power pin retaining thumb screw. MIG guns require a control wire assembly to connect the trigger leads to the unit. The control wire assembly is located near the power pin and plugs into the remote control socket.



WARNING!

The mains supply must be disconnected during installation.

- 1) Open wire feed compartment door and loosen retaining thumb screw.
- 2) Fit the MIG gun power pin into torch receptacle, insert fully.
- 3) Tighten retaining thumb screw.
- 4) Locate the control wire assembly, align keyway with the key on the remote control socket, insert plug, and rotate threaded collar fully clockwise.

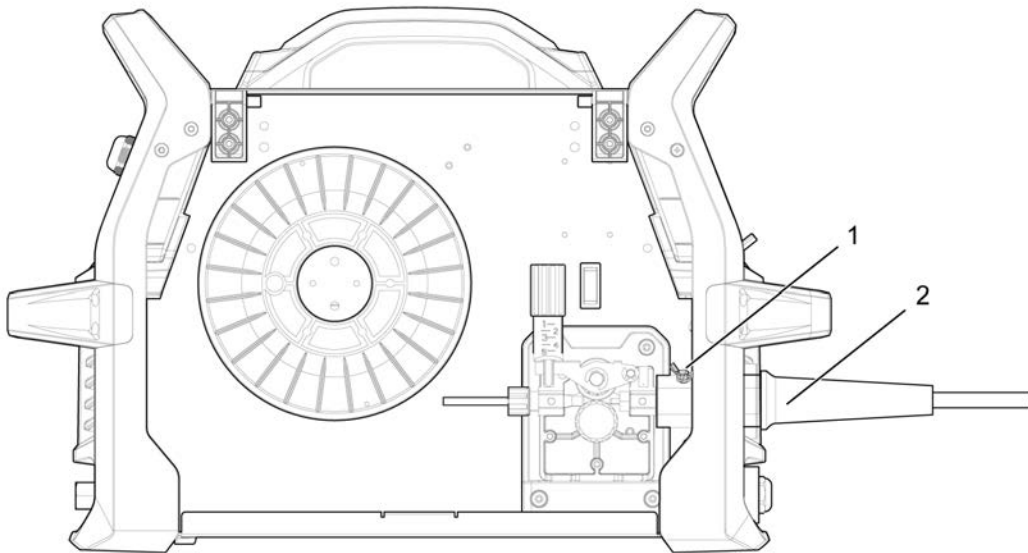

1. Thumb screw

2. Torch receptacle

5.5 Inserting and replacing wire

Rogue EMP 190 can be used with bobbin sizes of 100 mm (4 in.) and 200 mm (8 in.). See Section 3 "Technical data", page 8, for suitable wire dimensions for each wire type.



WARNING!

Do not place or point the torch near the face, hand or body as this may result in personal injury.



WARNING!

Make sure that the power is turned off, before replacing or installing any parts.



WARNING!

Risk of crushing when replacing the wire bobbin! Do **not** use safety gloves when inserting the welding wire between the feed rollers.

- 1) Open the spool side door.
- 2) Release the pressure roller arm with levering the tension screw (1).
- 3) Lift the pressure roller arm (2).
- 4) With the GMAW welding wire feeding from the bottom of the spool, pass the electrode wire through the inlet guide (3), between the rollers, through the outlet guide and into the GMAW torch. Ensure that the wire is aligned with the correct groove in the drive roll.
- 5) Re-secure the pressure roller arm and wire drive tension screw and adjust the pressure if necessary.
- 6) With the GMAW torch lead reasonably straight feed the wire through the GMAW torch by depressing the wire inch button or trigger switch.
- 7) Close the spool side door.

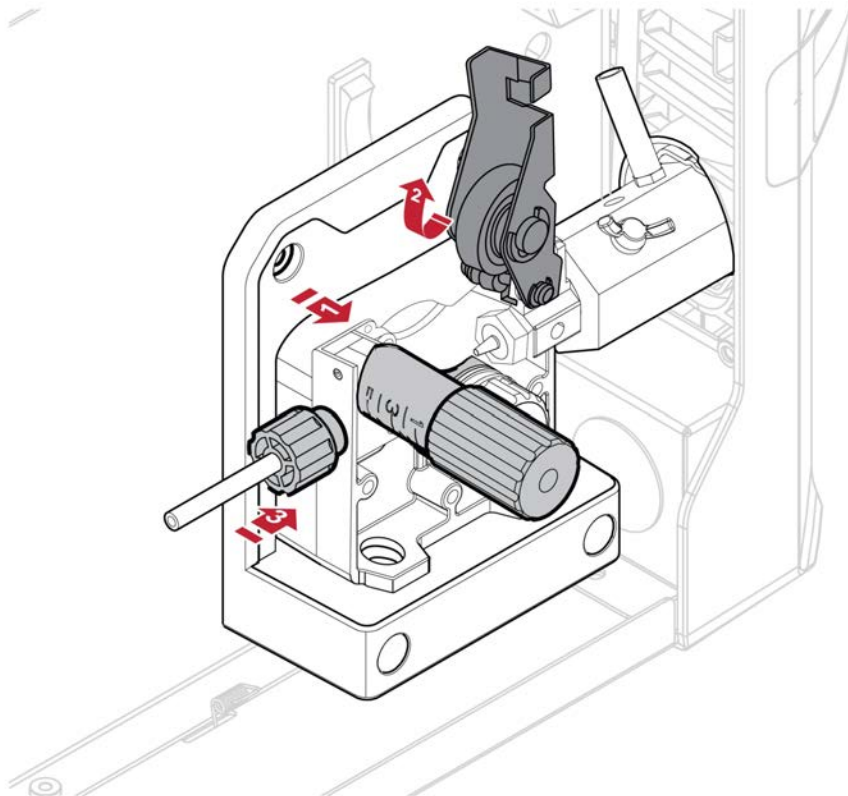

5.5.1 Welding with aluminium wire

NOTE!

Make sure the correct feed/pressure rollers are used. For more information see Section 11.3 "WEAR PARTS", page 39.

NOTE!

Make sure to use the correct contact tip in the welding torch for the wire diameter used. The torch is fitted with a contact tip for 0.030 in. (0.8 mm) wire. If you use another diameter, make sure to change the contact tip and drive roll. The wire liner fitted in the torch is recommended for welding with Fe and SS wires.

To ensure the best results welding aluminum with the MXL 210, use a Teflon liner and U groove drive roll and keep the torch conduit as straight as possible.

To weld with aluminum wire, use optional spool gun for the best result. Refer to Spool Gun Instruction Manual for the correct set up.

5.5.2 Installing 12.5 lb spool (8 in. diameter)

In order to fit a 12.5 lb spool (8 in. diameter) assemble parts in the sequence shown in the figure below. To install wire spool, follow the steps below.

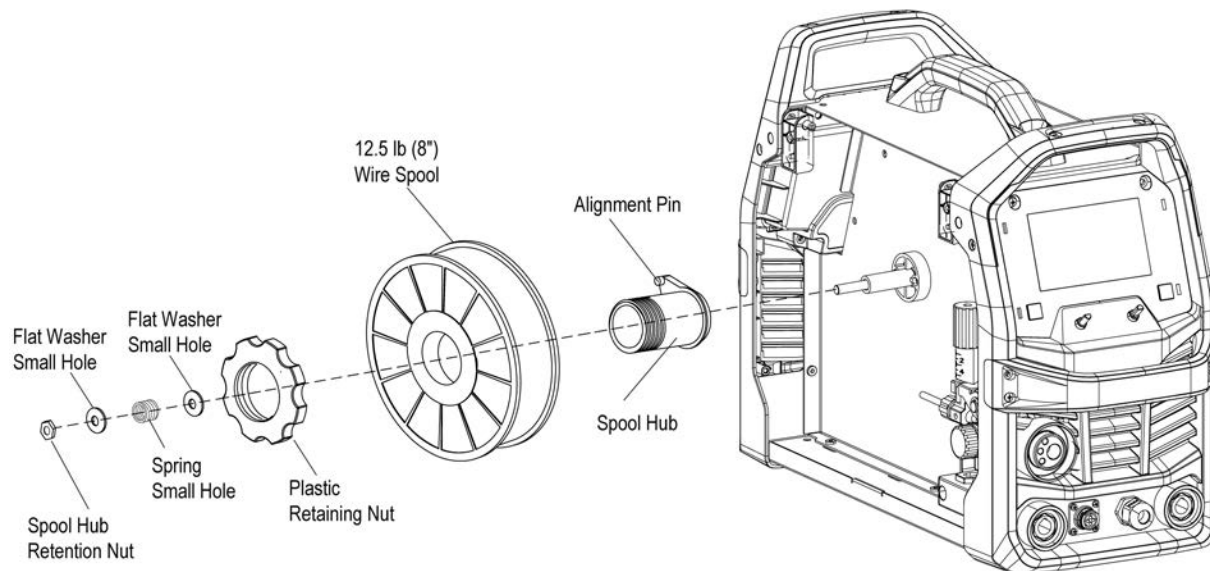

1. Remove plastic retaining nut.
2. Place wire spool onto the hub, loading it so that the wire will feed off the bottom of the spool as the spool rotates counterclockwise. Make sure to align the spool alignment pin on the hub with the mating hole in the wire spool.
3. Replace the plastic retaining nut until tight against wire spool.

5.5.3 Installing 2 lb spool (4 in. diameter)

In order to fit a 2 lb spool (4 in. diameter) assemble parts in the sequence shown in the figure below. To install wire spool, follow the steps below.

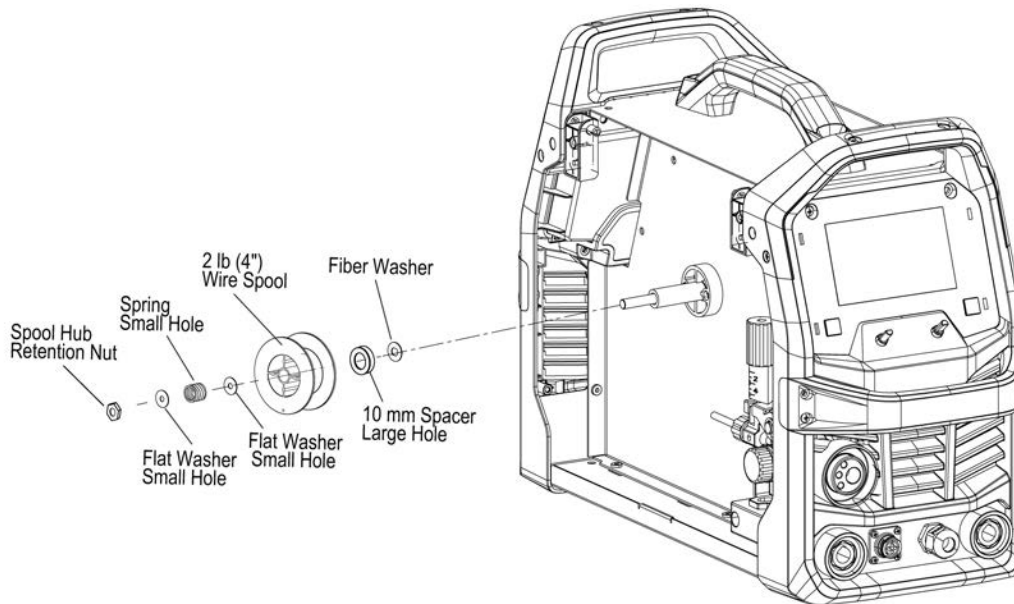

1. Remove plastic retaining nut.
2. Place wire spool onto the hub, loading it so that the wire will feed off the bottom of the spool as the spool rotates counterclockwise. Make sure to align the spool alignment pin on the hub with the mating hole in the wire spool.
3. Replace the plastic retaining nut until tight against wire spool.

5.6 Setting the wire feed pressure

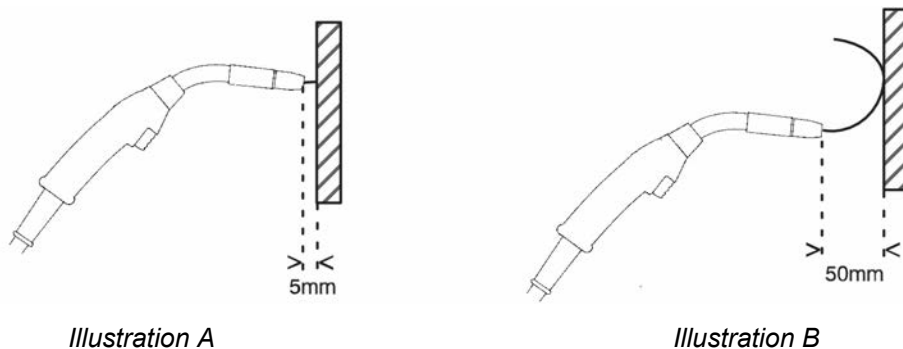

Illustration A

Illustration B

Start by making sure that the wire moves smoothly through the wire guide. Then set the pressure of the wire feeder's pressure rollers. It is important that the pressure is not too high.

To check that the feed pressure is set correctly, you can feed out the wire against an insulated object, e.g. a piece of wood.

When you hold the welding torch approximately 5 mm (0.2 in.) from the piece of wood (illustration A), the feed rollers should slip.

If you hold the welding torch approximately 50 mm (2 in.) from the piece of wood, the wire should be fed out and bend (Illustration B).

The wire reel hub incorporates a friction brake which is adjusted during manufacture for optimum braking. If it is considered necessary, adjustment can be made by turning the thumb screw inside the open end of the hub clockwise to tighten the brake. Correct adjustment will result in the wire reel circumference continuing no further than 1/8 in.-3/16 in. (3-5 mm) after release of the trigger. The electrode wire should be slack without becoming dislodged from wire spool.

**CAUTION!**

Overtension of the brake will cause rapid wear of mechanical wire feeder parts, overheating of electrical components and possibly more incidences of contact tip burnback.

5.7 Changing the feed/pressure rollers

Three dual groove feed roller are supplied as standard. Change the feed roller to match the filler metal wire diameter.

**NOTE!**

Make sure not to lose the key that is located on the drive motor shaft. This key must be in place and align with drive roll slot for proper operation.

- 1) Open the spool side door.
- 2) Release the pressure roller arm with levering the tension screw.
- 3) Lift the pressure roller arm.
- 4) Remove the feed roll retaining screw by turning it counterclockwise.
- 5) Change the feed roll.
- 6) Tighten the feed roll retaining screw by turning it clockwise.
- 7) Secure the pressure roller arm and wire drive tension screw.
- 8) Close the spool side door.

**NOTE!**

Visual indication on the face of the drive roll indicates the diameter of the groove on the outside of the drive roll and the groove that is in use for the selected wire diameter.

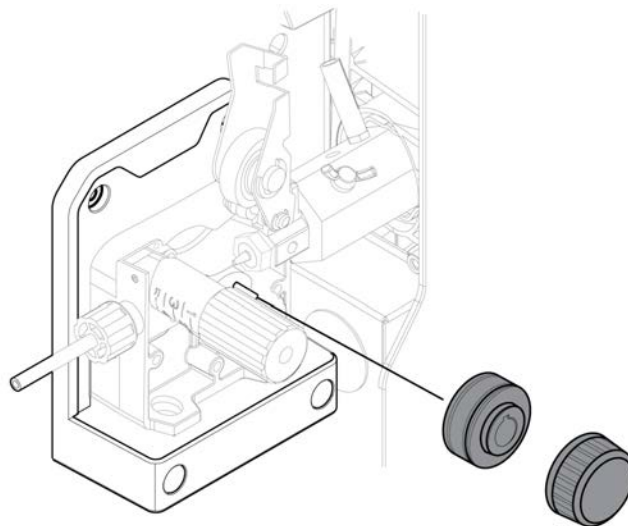
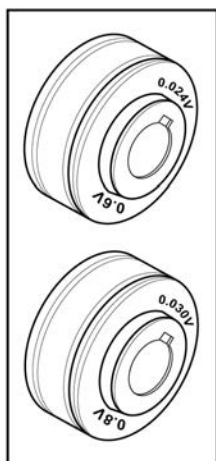

5.8 Shielding gas

The choice of suitable shielding gas depends on the material. Typically mild steel is welded with mixed gas (Ar + CO₂) or 100% carbon dioxide (CO₂). Stainless Steel can be welded with mixed gas

(Ar + CO₂). Aluminum can be welded with argon gas (Ar) and silicon bronze can be welded with use pure argon gas (Ar) or (Ar + O₂).

5.9 Duty cycle

The Rogue EMP 210 PRO has a welding current output of 210 A at 25% duty cycle (230 V). A self-resetting thermostat will protect the power source if the duty cycle is exceeded.

Example: If the power source operates at a 25% duty cycle, it will provide the rated amperage for a maximum of 2.5 minutes out of every 10-minute period. The remaining time, 7.5 minutes, the power source must be allowed to cool down.

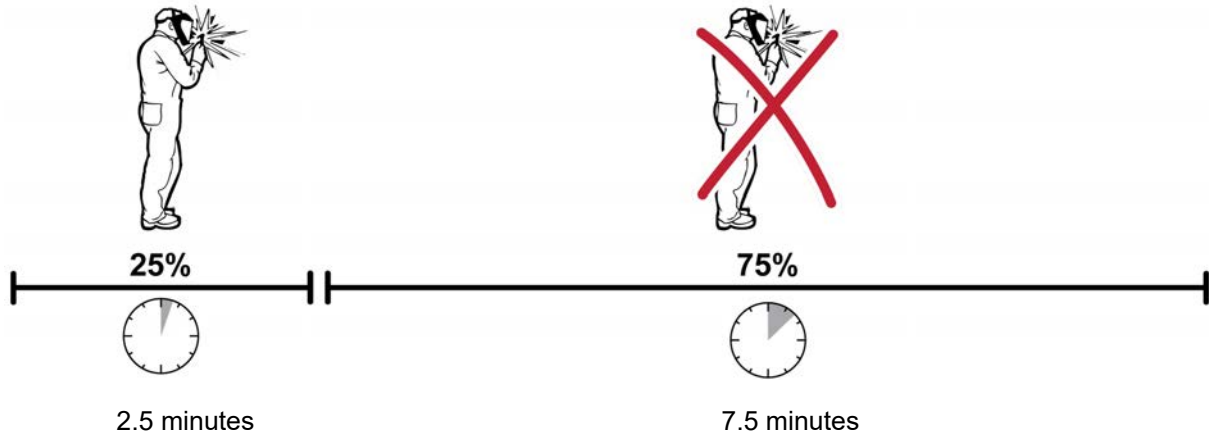

A different combination of duty cycle and welding current can be selected.

6 USER INTERFACE

General safety regulations for handling the equipment can be found in the "SAFETY" chapter of this manual. General information about operation can be found in the "OPERATION" chapter of this manual. Read both chapters thoroughly before you start using the equipment.

After power on has completed, the main menu appears on the user interface.

6.1 Home screen

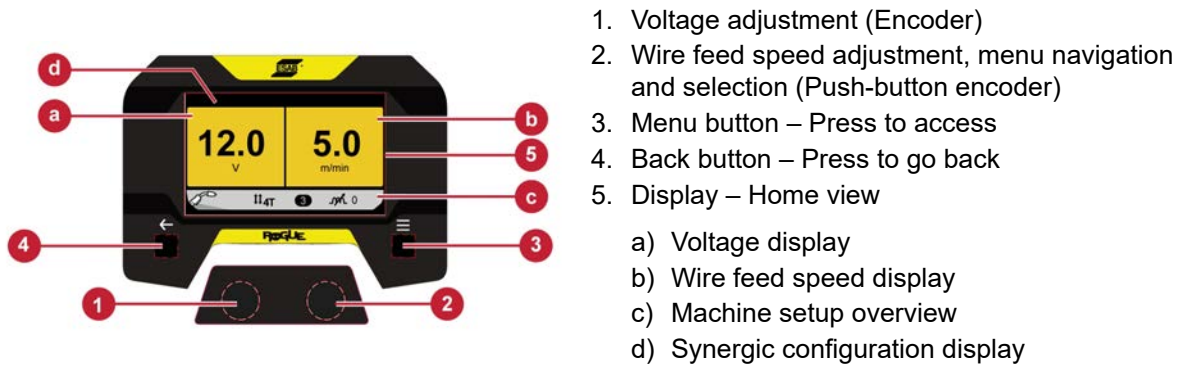

1. Voltage adjustment (Encoder)
2. Wire feed speed adjustment, menu navigation and selection (Push-button encoder)
3. Menu button – Press to access
4. Back button – Press to go back
5. Display – Home view

- a) Voltage display
- b) Wire feed speed display
- c) Machine setup overview
- d) Synergic configuration display

6.2 Navigation

1. Left-hand encoder – used to trim the voltage in GMAW Synergic mode or to adjust voltage in GMAW Manual mode.
2. Right-hand push button encoder – used to adjust the material thickness in GMAW Synergic mode or adjust wire feed speed in GMAW Manual mode.
3. Menu button – provides access to the system menu allowing for custom configuration. See Section 6.3 "GMAW Synergic mode", page 23 and Section 6.4 "GMAW Manual mode", page 23.
4. Back button – returns the user to the previous screen in GMAW Synergic or GWAM Manual modes.
5. User display – at the home view the display is segmented to four sections:
 - a) Left-hand side – displays preset Voltage in both GMAW Synergic and GMAW Manual modes and actual Voltage while welding.
 - b) Right-hand side – displays preset material thickness in GMAW Synergic mode and preset wire feed speed in GMAW Manual mode. Welding current will be also displayed while welding.
 - c) Gutter ribbon – provides the user with brief overview of the machine set up.
 - d) Header ribbon – provides the user with an overview of the selected material, wire diameter, and gas type that has been selected in the synergic mode.



NOTE!

After welding, the display hold the last actual welding parameters and the duration of the weld for 10 seconds.

6.3 GMAW Synergic mode

GMAW Synergic mode is a constant voltage weld process where voltage and wire feed speed are in relation using predetermined synergic data, providing stable arc performance throughout the range of a given wire and gas combination.

Synergic mode operates in short circuit, globular, and spray transfer modes.

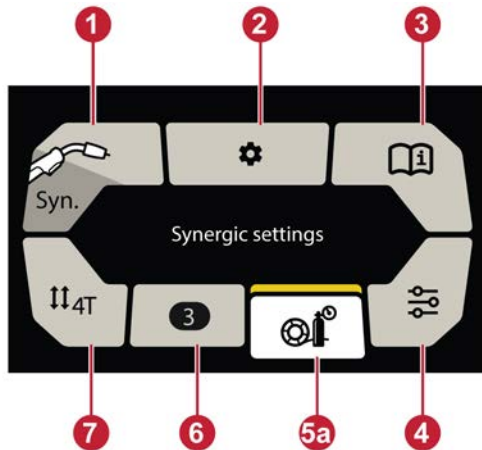

1. Process selection
2. Settings
3. Information
4. Weld variables
5. Synergic settings
6. Jobs
7. Trigger selection

6.4 GMAW Manual mode

GMAW Manual mode is a constant voltage weld process where the voltage and wire feed speed are set independent of each other.

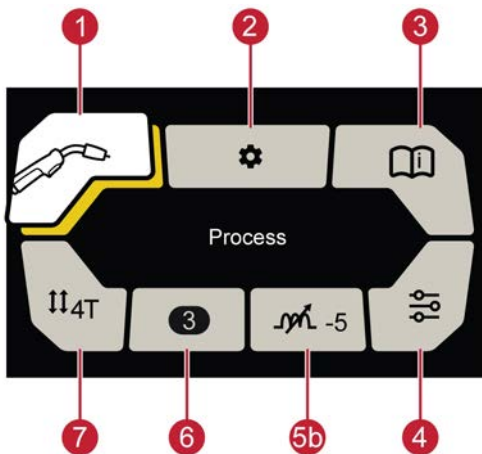

1. Process selection
2. Settings
3. Information
4. Weld variables
5. Arc dynamics
6. Jobs
7. Trigger selection

To select and enter any of the tiles rotate right-hand push button encoder to the desired tile and press the encoder. After the user enters there will be various options to select from.

1. **Process Selection**– provides the option of selecting Synergic GMAW, Manual GMAW, SMW (MMA) or Live GTAW mode.
2. **Settings** – provides the option to configure various settings that can be selected or viewed by the operator on a system level.
 - Language selection
 - Unit of measure (in./mm)
 - Display brightness
 - Trigger Job shift (multiple Jobs available to operator)
 - Factory reset
 - About (software version)

**NOTE!**

Factory reset will delete all custom configurations and reset the unit to the original factory configuration. Total arc time will not be deleted or reset to factory configuration.

3. **Information** – provides the option to configure various settings that can be selected or viewed by the operator on a system level.
 - Wears and Spares
 - Accessories
 - Filler metals
 - General maintenance
 - User manual
4. **Weld Variables** – provides the option the set specific welding variables that can enhance the weld results.
 - **Arc dynamics** – used to adjust the intensity of the welding arc. Lower arc control settings make the arc softer with less weld spatter and better wetting action of the weld puddle. Higher arc control settings give a more driving arc which can increase weld penetration. Setting range -9 to +9.
 - **Preflow time** – the time during which shielding gas flows before the arc is struck. Setting range 0.0-5.0 s.
 - **Creep start** – feeds the wire at a lower wire feed speed than preset wire feed speed, until it makes electrical contact with the workpiece, transitioning to preset wire feed speed. Set as percentage of preset wire feed speed.
 - **Burnback time** – Burnback is a time delay between the time when the wire starts to brake until the time when the power source disables the welding output. Setting range 0.01-0.35 s. Too short burnback time will result in a long wire stick out after completion of welding, with the risk of the wire being stuck in the solidifying weld pool. Too long a burnback time results in a shorter stick out, with increased risk of the wire burning back to the contact tip.
 - **Postflow time** – Post-flow is the time during which shielding gas flows after the arc is extinguished. Setting range 0.0-10.0 s.
5. **GMAW Modes:**
 - a) **GMAW Synergic mode:**

Synergic settings - Allows the user to configure the machine for a specific wire type, wire diameter, and gas combination. This optimizes the welding parameters from the minimum to maximum material thicknesses that the machine or process is capable of welding.

**NOTE!**

Mild Steel (Fe) is used in the example below. Other combinations are available.

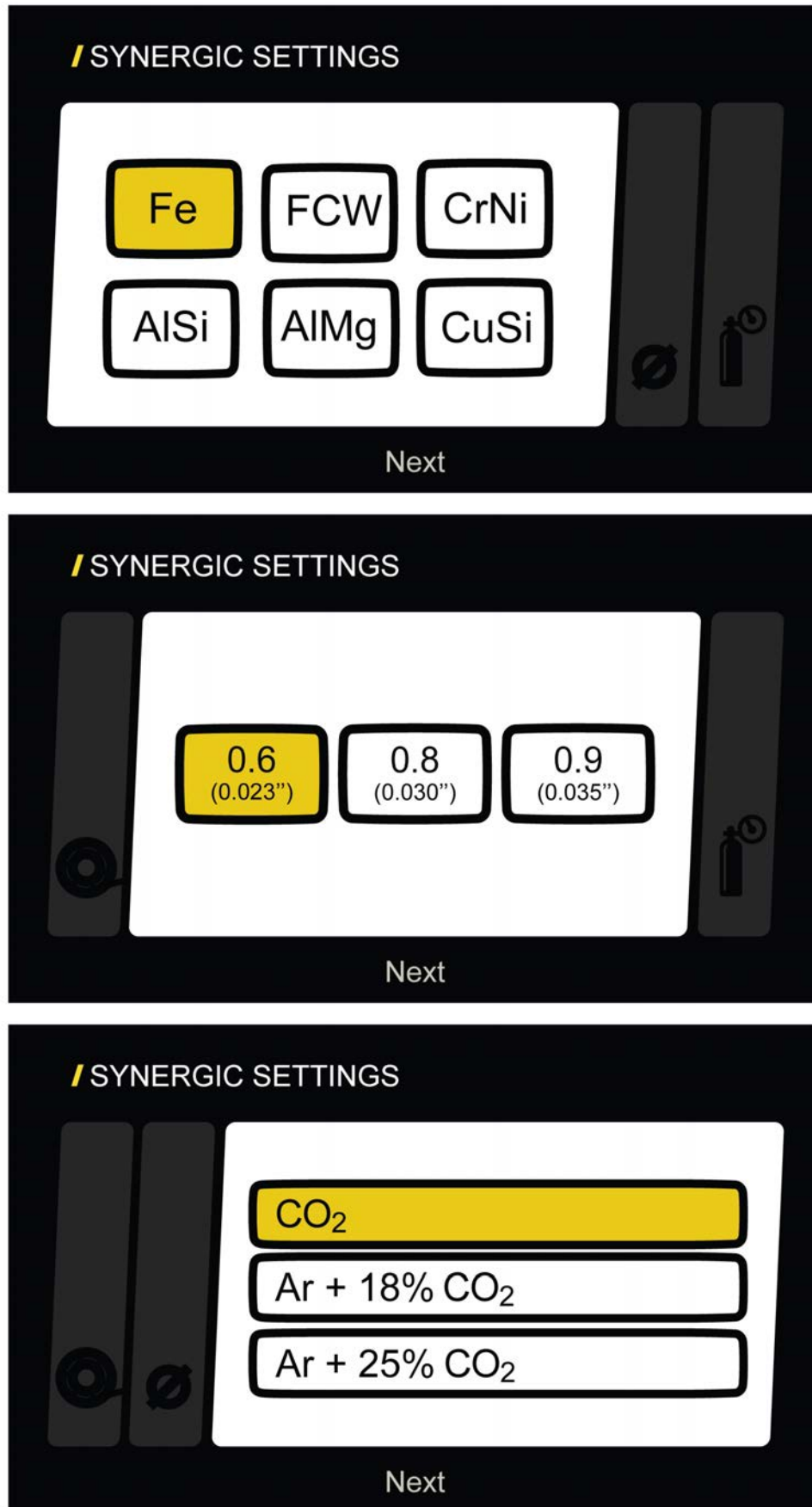

b) **GMAW Manual mode:**

Arc dynamics - Used to adjust the intensity of the welding arc. Lower arc control settings make the arc softer with less weld spatter and better wetting action of the weld puddle. Higher arc control settings give a more driving arc which can increase weld penetration. Setting range -9 to +9.

6. **Jobs** – provides the user the option to easily save and recall specific welding condition that are used on a frequent basis.

- **To create Jobs** – it is required to establish specific welding parameters that are desired in synergic or manual mode.
- **To save Jobs** – first is to create the welding parameters. Access the menu and select the Jobs tile. There are 10 individual Jobs that can be created for each process setting. Use the push button encoder to select the desired job number. When the desired Job number is selected, press, and hold the encoder for 2 seconds. The job is now saved. The parameters that were established are displayed in the Job tile and will be the active Job. The Job number will be displayed on the home screen.
- **To delete Jobs** - Access the menu and select the Jobs tile. Use the push button encoder to select the desired job number. When the desired Job number is selected, press, and hold the back button for 5 seconds. The job is now deleted.
- **Trigger Job Call** - allows the user to trigger between preprogrammed Jobs while welding. The individual Jobs must be established in advance of use. Under the Setting Tile turn on Trigger Job Call. Under this menu, the option to select 1 & 2 or 1, 2, & 3 depending on the number of Jobs the user want to select. Allowing the user to trigger/toggle between Jobs 1 & 2 or Jobs 1, 2 & 3 with the trigger while welding. Trigger Job Call only functions in the 4T Trigger configuration.

7. **Trigger Selection** – provides the user with the ability to control the trigger functionality.

- **2-stroke**
With 2-stroke, gas pre-flow starts when the welding torch trigger is pressed if feature is active. The welding process then starts. Releasing the torch trigger stops welding entirely and starts gas post-flow if feature is active.
- **4-stroke**
With 4-stroke, the gas pre-flow starts when the welding torch trigger is pressed, and the wire feed starts when it is released, and welding will begin. The welding process continues until the torch trigger is pressed again, the wire feed and welding stops. When the torch trigger is released the gas post-flow starts.
- **Spot**
The spot function enables the user to set a specific length of weld time each time the torch trigger is depressed. Setting range 0-10.0 s
- **Stitch**
The stitch function enables the user to set two independent times, stitch time and dwell time. These times will repeat as long the torch trigger is depressed. Setting range: Stitch time 0.0-10.0 s, dwell time 0.0-10.0 s

6.5 SMAW (MMA) mode

GMAW Manual mode is a constant voltage weld process where the voltage and wire feed speed are set independent of each other.

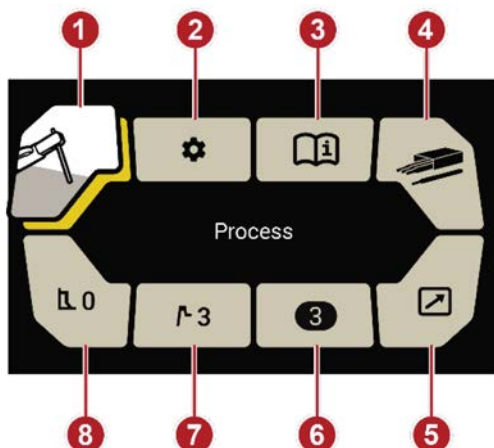

1. Process selection
2. Settings
3. Information
4. Electrode type
5. Remote
6. Jobs
7. Hot start
8. Arc force

1. **Process Selection**– See Section 6.4 "GMAW Manual mode", page 23.
2. **Settings** – See Section 6.4 "GMAW Manual mode", page 23.
3. **Information** – See Section 6.4 "GMAW Manual mode", page 23.
4. **Electrode type** – allows the user to select between cellulosic (6010) or basic/rutile electrodes (most others). This will determine the type of arc characteristic that is best suited to run that type of electrode.
5. **Remote** - when paired with the MMA-4 remote hand control, current/amperage can be increased or decreased at the weld site.
6. **Jobs** – See Section 6.4 "GMAW Manual mode", page 23.
7. **Hot start** – controls the amount of additional amperage at arc initiation to prevent the electrode from sticking to the work piece and preventing a cold start at the beginning of the weld. Increase the Hot start value if having difficulty striking the arc or decrease the Hot start value when electrode appears to flare excessively at the start of the weld. (Range 0-10).
8. **Arc force** - controls the amount of additional amperage when in short arc length condition. Increase the arc force percentage when in a tight or narrow weld joint or decrease the arc force percentage when welding a normal weld joint. (Range 0-10).

6.6 Live GTAW mode

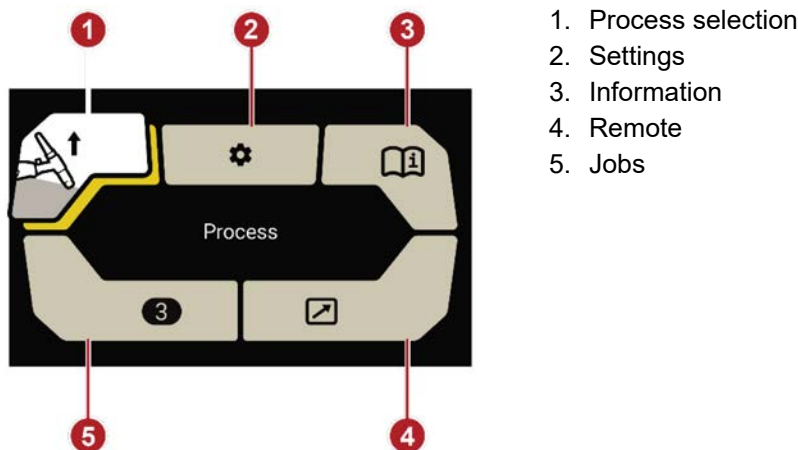

GTAW welding melts the metal of the workpiece, with an arc initiated from a non-consuming tungsten electrode. The weld pool and electrode are protected by shielding gas.







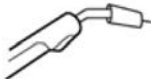
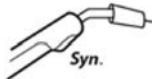



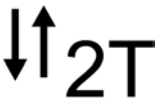







1. Process selection
2. Settings
3. Information
4. Remote
5. Jobs

1. **Process Selection**– See Section 6.4 "GMAW Manual mode", page 23.
2. **Settings** – See Section 6.4 "GMAW Manual mode", page 23.
3. **Information** – See Section 6.4 "GMAW Manual mode", page 23.
4. **Remote** - when paired with the TWECO TIG Foot Control, current/amperage can be increased or decreased at the weld site.
5. **Jobs** – See Section 6.4 "GMAW Manual mode", page 23.

6.7 Icon reference guide

	GMAW Manual		GMAW Synergic
	Stick		LIVE GTAW

	2T, Trigger On/Off		4T, Trigger Hold/Lock
	Arc dynamics		Arc force On stick welding- increasing amps when the arc length is shortened to reduce or eliminate the freezing of the stick electrode in the weld puddle.
	Hot start The increase of amps when striking the electrode to reduce sticking.		Information
	Jobs		Remote
	Settings		Spot weld
	Synergic setting		Weld variables
	Electrode type		Voltage
	Amps		Wire feed speed

7 MAINTENANCE

NOTE!

Regular maintenance is important for safe and reliable operation.

CAUTION!

Repair and electrical work should be performed by an authorised ESAB service technician. Use only ESAB original spare and wear parts.

CAUTION!

All warranty undertakings from the supplier cease to apply if the customer attempts any work to rectify any faults in the product during the warranty period.

WARNING!

The mains supply must be disconnected during cleaning and maintenance.

NOTE!





Perform maintenance more often during severe dusty conditions.



Before each use - make sure that:

- Product and cables are not damaged.
- The torch is clean and not damaged.

7.1 Routine maintenance

Maintenance schedule during normal conditions. Check equipment prior to every use.

Interval	Area to maintain	
Each use	 Visual check of regulator and pressure	 Visual check of torch consumable
Weekly	 Visually inspect the torch body and consumables	 Visually inspect the cables and leads. Replace if necessary

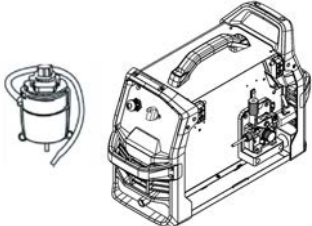
Interval	Area to maintain	
Every 3 months	 Replace all broken parts	 Clean exterior of power source
Every 6 months	 Bring the unit to an authorized service provider to remove any accumulated dirt and dust from the interior. This may need to be done more frequently under exceptionally dirty conditions.	

7.2 Power source and wire feeder maintenance

General practice is to perform a power source cleaning each time a wire bobbin is replaced.

**WARNING!**

Always wear safety gloves and protective eye wear during cleaning.

Power source and wire feeder cleaning procedure:

- 1) Disconnect the power source from the input power receptacle.
- 2) Open the spool side door and release the tension from the pressure roller by turning the tension screw (1) counterclockwise and move it outward.
- 3) Remove the torch, wire, and wire bobbin.
- 4) Use a low-pressure dry airline to clean the power source interior and power source air inlet and outlet louvers.
- 5) Inspect the wire inlet guide (4), the drive roll (3), and torch inlet (2) for wear. If any item is worn, replace immediately. See Section 11.3 "WEAR PARTS", page 39 for ordering replacement items.
- 6) Remove and clean the feed roller (3) with a soft brush. Clean the pressure roller attached to the wire feeder mechanism with a soft brush.

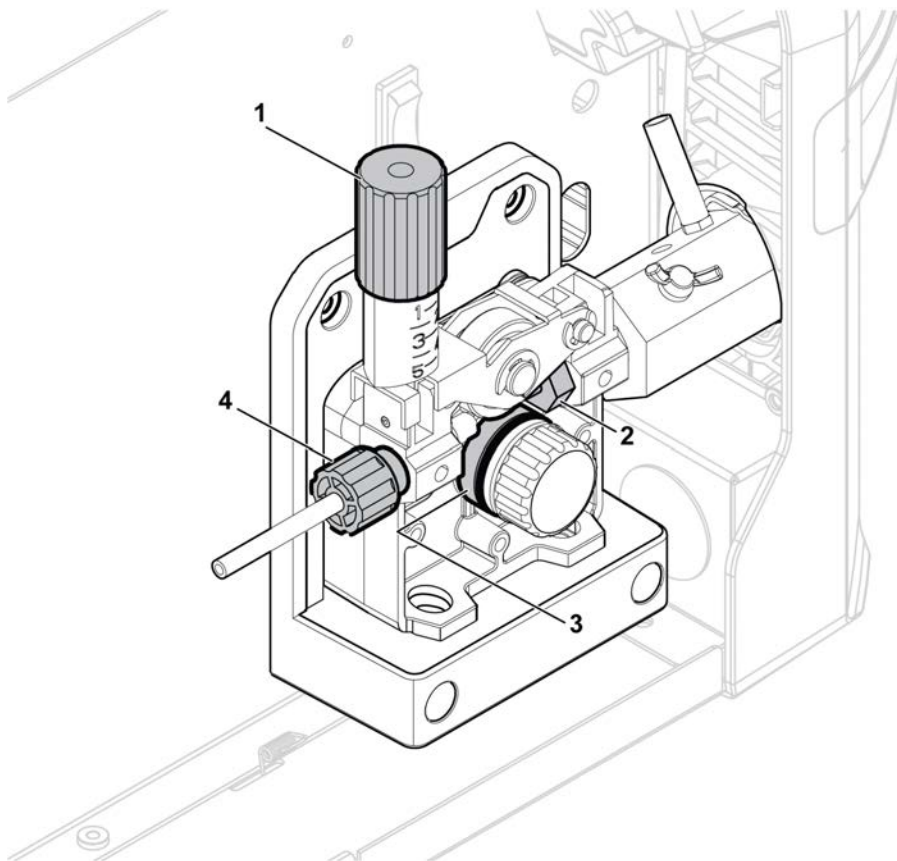

7.3 Torch and liner maintenance

Torch and liner cleaning procedure:

- 1) Disconnect the power source from the input power receptable.
- 2) Open the spool side door and release the tension from the pressure roller by turning the tension screw counterclockwise and move it outward.
- 3) Remove the wire and the wire bobbin.
- 4) Remove the torch from the power source and remove the contact tip and nozzle.
- 5) Clean the liner by blowing low-pressure dry compressed through the end of the liner that was mounted closest to the power source.
- 6) Re-install contact tip and nozzle.

8 ERROR CODES

The error code is used to indicate that a fault has occurred in the equipment. Errors are indicated by the text "Error" followed by the error code number shown in the display.

8.1 Error code descriptions

Error codes that the user can handle are listed below. If any other error code appears, contact an authorised ESAB service technician.

Error codes	Title	Display information	Description	Action
002	Shorted trigger	Error 002 Shorted trigger	There is a fault in torch, or the 8-pin connector.	Release the trigger.
205	Mains power under voltage	Error 205 Mains power under voltage	The product has detected that the incoming mains power is outside of the product specifications.	Make sure that the mains power is within the product specification.
205	Mains power over voltage	Error 205 Mains power over voltage	The product has detected that the incoming mains power is outside of the product specifications.	Make sure that the mains power is within the product specification.
206	Over temperature	Error 206 Over temperature	The unit has overheated and shutdown to allow the fan to cool it down. Welding can resume once the unit has cooled.	Wait until the temperature cools down.
215	Stuck Check (STICK)	Error 215 Over temperature	Stick electrode is stuck to the work piece. Clear the short and cycle power to resume welding.	Break stuck stick electrode.
215	Stuck Check (GTAW)	Error 215 Over temperature	Tungsten electrode is stuck to the work piece. Clear the short and cycle power to resume welding.	Break stuck tungsten electrode.
216	Over current	Error 216 Output current exceeded	Output amperage exceeded design maximum.	Reduce settings and resume welding.
216	Output short circuit	Error 216 Output short circuit	Short circuit has been detected during output activation.	Remove short circuit condition.

9 TROUBLESHOOTING

Perform these checks and inspections before sending for an authorised service technician.

Type of fault	Corrective action
Porosity within the weld metal	Check gas bottle is not empty.
	Check gas regulator is not closed.
	Check gas inlet hose for leaks or blockage.
	Check that the correct gas is connected and the correct gas flow is used.
	Keep the distance between the GMAW torch nozzle and the work piece to a minimum.
	Do not work in areas with drafts, which would disburse the shielding gas, are common.
	Make sure the work piece is clean, with no oil or grease on the surface, before welding.
Wire feeding problems	Make sure the wire spool brake is adjusted correctly.
	Make sure the feed roller is correct size and not worn.
	Make sure the correct pressure is set on the feed rollers.
	Make sure the correct contact tip is used and it is not worn.
	Make sure liner is the right size and type for wire.
	Make sure the liner is not bent so that friction is caused between the liner and the wire.
GMAW (MIG) welding problems	Make sure the torch is connected to the correct polarity.
	Replace contact tip if it has arc marks in the bore causing excessive drag on the wire.
	Make sure the correct shielding gas, gas flow, voltage, welding current, travel speed and torch angle is used.
	Make sure the work lead has proper contact with the work piece.
SMAW (MMA) basic welding problems	Make sure you are using the correct polarity. The electrode holder is usually connected to the positive polarity and the work lead to the negative polarity.
GTAW (TIG) welding problems	Make sure the GTAW torch is connected to the power source: Connect the GTAW torch to the negative [-] welding terminal and connect the welding ground cable to the positive [+] welding terminal.
	Use only 100% Argon gas for GTAW welding.
	Make sure the regulator/flow meter is connected to the gas bottle.
	Make sure the gas pipe for the GTAW torch is connected to the gas outlet connector on the front of the power source.
	Make sure the work clamp has proper contact with the work piece.
	Make sure the power source is turned on and GTAW welding process is selected.
	Make sure all connections are tight and leak-free.

Type of fault	Corrective action
No power/No arc	Check that the input power supply switch is turned ON.
	Check if a temperature fault is shown on display.
	Check if system breaker is tripped.
	Check that the input power, welding and return cables are correctly connected.
	Check that the correct current value is set.
	Check the input power supply fuses.
The overheating protection trips frequently	Make sure that you are not exceeding the recommended duty cycle for the weld current you are using. See Section .
	Make sure the air inlets or outlets are not clogged.

10 ORDERING SPARE PARTS



CAUTION!

Repair and electrical work should be performed by an authorised ESAB service technician. Use only ESAB original spare and wear parts.

The Rogue EMP 210 PRO is designed and tested in accordance with the international standards **IEC/EN 60974-1** and **IEC/EN 60974-1 Class A**. On completion of service or repair work, it is the responsibility of the person(s) performing the work to ensure that the product still complies with the requirements of the above standards.

Spare parts and wear parts can be ordered through your nearest ESAB dealer, see esab.com. When ordering, please state product type, serial number, designation and spare part number in accordance with the spare parts list. This facilitates dispatch and ensures correct delivery.

The spare parts list is published in a separate document that can be downloaded from the Internet: www.esab.com

APPENDIX

WIRING DIAGRAM

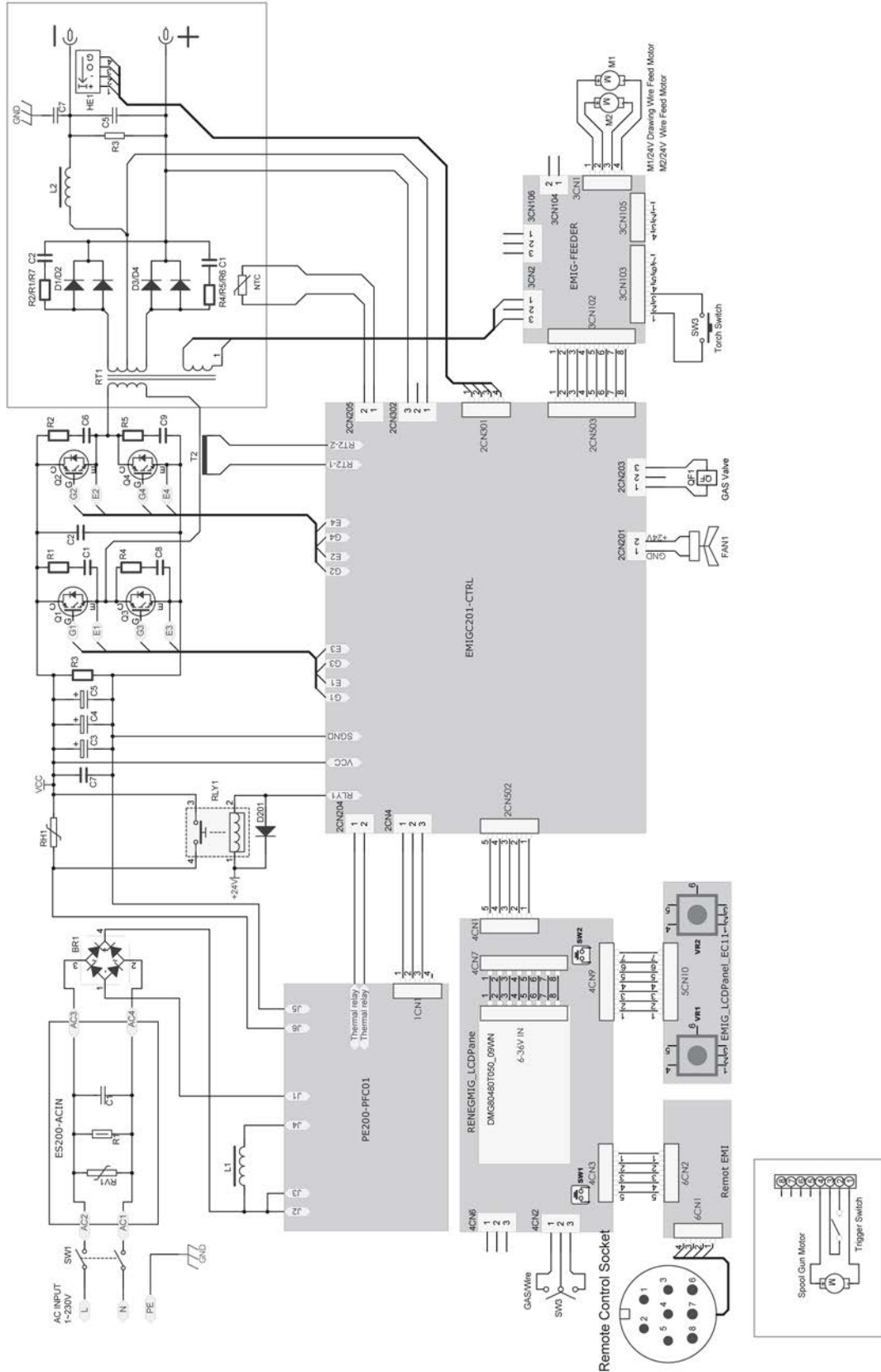

ORDERING NUMBERS

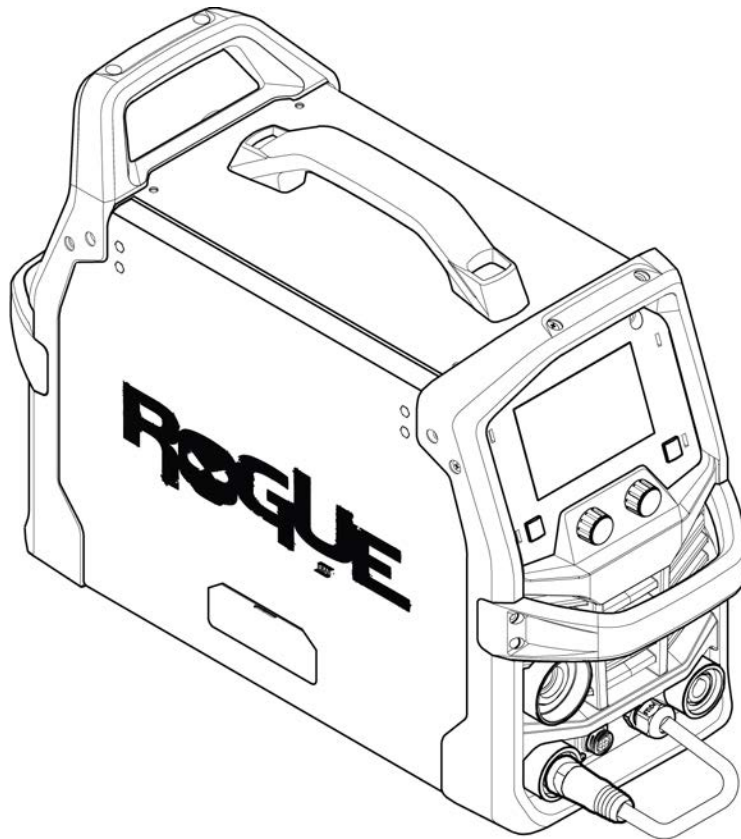

Ordering number	Denomination	Type	Notes
0700 301 092	Power source with wire feeder	Rogue EMP 210 PRO	EU

Technical documentation is available on the Internet at: www.esab.com

WEAR PARTS

Ordering number	Denomination	Wire dimensions
	Drive rolls	
0367556001	Feed roller for V	0.6 and 0.8 mm
0367556002	Feedroll V groove	0.8/1.0 mm
0367556003	Feed roller V groove	1.0 and 1.2 mm
0367556004	Feedroll U groove	1.0/1.2 mm
0349312497	Drive roll, Knurled V-groove	0.9/1.2 mm
0558102928	Wire guide, inlet	
0558102929	Wire guide, outlet	
0558102930	Motor drive key shaft	

ACCESSORIES

0460 330 880	Trolley 2-wheel with cylinder support
0700 025 220	MXL 201, Euro connection, 3 m
0700 025 221	MXL 201, Euro connection, 4 m
0349 312 105	Gas hose, 4.5 m
0700 006 901	Work clamp leadset, 3 m, 16 mm ² , 35-50 OKC
0700 006 900	Electrode holder leadset, 3 m, 16 mm ² , 35-50 OKC
0700 500 084	MMA 4, Remote control, 10 m
W4014450	TIG foot control, 4.5 m, 8-pin connector



A WORLD OF PRODUCTS AND SOLUTIONS.



For contact information visit <http://esab.com>

ESAB AB, Lindholmsallén 9, Box 8004, 402 77 Gothenburg, Sweden, Phone +46 (0) 31 50 90 00

manuals.esab.com



CE

