

WELD STAR

USER MANUAL

WS-MU4-1



INFINIUM

Introduction to your new product

Thank you for selecting this Weld Star Infinium product.

This product manual has been designed to ensure that you get the most from your new Weld Star product. Please ensure that you are fully conversant with the information provided paying particular attention to the safety precautions. The information will help protect yourself and others against the potential hazards that you may come across.

Please ensure that you carry out daily and periodic maintenance checks to ensure years of reliable and trouble free operation.

Please call your Weld Star distributor in the unlikely event of a problem occurring. Please record below the details of your new Weld Star product as these may be required for warranty purposes should you require assistance or spare parts.

Date purchased _____

Purchased from _____

Model name _____

Serial number _____

(The serial number is normally located on the product packaging, top or underside of the machine)

Disclaimer

Whilst every effort has been made to ensure that the information contained within this manual is complete and accurate, no liability can be accepted for any errors or omissions.

Please note:

Products are subject to continual development and may be subject to change without notice. www.weldstar.uk

No part of this manual may be copied or reproduced by any means without the written permission of Wilkinson Star Limited.



CONTENTS

	Page
Your New Product	2
Index	3
Safety Instruction	4
General electrical and operating safety	4
PPE and Welding processes lens shade selector guide	5
Fume and welding gases and fire risks	6
The working environment, Magnetic fields and cylinder safety	7
Noise and fire awareness, hot parts and RF/LF declarations	8
Materials and their disposal	9
Package Contents and Unpacking	9
Product Overview	10
Product Technical Specifications	11
Description of Controls	12
Installation Information	14
Display Interface Explained	16
Operation - MIG/MAG	18
Operation - TIG	23
Operation - MMA	29
Guide to MIG/MAG Welding	32
Guide to TIG Welding	41
Guide to MMA Welding	55
Settings	60
Remote Control (Wired)	61
Remote Control (Wireless)	63
Maintenance	64
Service Schedule	64
Troubleshooting	65
Error Codes	66
Electrical Schematic	67
WEEE Disposal	68
RoHS Compliance Declaration	68
UKCA Declaration of Conformity	68
EC Declaration of Conformity	69
Statement of Warranty	70
Options and Accessories	71
Memory Storage	71
Notes	72
Weld Star Contact Details	74

SAFETY INSTRUCTIONS



These general safety norms cover both arc welding machines and plasma cutting machines unless otherwise noted. The user is responsible for installing and operating the equipment in accordance with the enclosed instructions.

It is important that users of this equipment protect themselves and others from harm, or even death. The equipment must only be used for the purpose it was designed for. Using it in any other way could result in damage or injury and in breach of the safety rules.

Only suitably trained and competent persons should operate the equipment.

Pacemaker wearers should consult their doctor prior to using this equipment.

PPE and workplace safety equipment must be compatible for the application of the work involved.

Always carry out a risk assessment before carrying out any welding or cutting activity.

General electrical safety



Danger
Electric shock risk

The equipment should be installed by a qualified person and in accordance with current standards in operation.

It is the users responsibility to ensure that the equipment is connected to a suitable power supply. Consult your utility supplier if required.

Do not use the equipment with the covers removed. Do not touch live electrical parts or parts which are electrically charged. Turn off all equipment when not in use.

In the case of abnormal behaviour of the equipment, the equipment should be checked by a suitably qualified service engineer.

If earth bonding of the work piece is required, bond it directly with a separate cable with a current carrying capacity capable of carrying the maximum capacity of the machine current.

Cables (both primary supply and welding) should be regularly checked for damage and overheating.

Never use worn, damaged, under sized or poorly jointed cables.

Insulate yourself from work and earth using dry insulating mats or covers big enough to prevent any physical contact.

Never touch the electrode if you are in contact with the work piece return.

Do not wrap cables over your body.

Ensure that you take additional safety precautions when you are welding in electrically hazardous conditions such as damp environments, wearing wet clothing and metal structures.

Try to avoid welding in cramped or restricted positions.

Ensure that the equipment is well maintained. Repair or replace damaged or defective parts immediately.

Carry out any regular maintenance in accordance with the manufacturers instructions.

The EMC classification of this product is class A in accordance with electromagnetic compatibility standards CISPR 11 and IEC 60974-10 and therefore the product is designed to be used in industrial environments only.

WARNING: This class A equipment is not intended for use in residential locations where the electrical power is provided by a public low-voltage supply system. In those locations it may be difficult to ensure the electromagnetic compatibility due to conducted and radiated disturbances.

General operating safety



Never carry the equipment or suspend it by the carrying strap or handles during welding.

Never pull or lift the machine by the welding torch or other cables.

Always use the correct lift points or handles. Always use the transport under gear as recommended by the manufacturer.

Never lift a machine with the gas cylinder mounted on it.

If the operating environment is classified as dangerous, only use S-marked welding equipment with a safe idle voltage level. Such environments may be for example: humid, hot or restricted accessibility spaces.

SAFETY INSTRUCTION

Use of Personal Protective Equipment (PPE)

⚠ CAUTION Welding arc rays from all welding and cutting processes can produce intense, visible and invisible (ultraviolet and infrared) rays that can burn eyes and skin.
PPE REQUIRED AT ALL TIMES

- Wear an approved welding helmet fitted with an appropriate shade of filter lens to protect your face and eyes when welding, cutting or watching.
- Wear approved safety glasses with side shields under your helmet.
- Never use any equipment that is damaged, broken or faulty.
- Always ensure there are adequate protective screens or barriers to protect others from flash, glare and sparks from the welding and cutting area.
- Ensure that there are adequate warnings that welding or cutting is taking place.
- Wear suitable protective flame resistant clothing, gloves and footwear.
- Ensure adequate extraction and ventilation is in place prior to welding and cutting to protect users and all workers nearby.
- Check and be sure the area is safe and clear of flammable material before carrying out any welding or cutting.



Some welding and cutting operations may produce noise. Wear safety ear protection to protect your hearing if the ambient noise level exceeds the local allowable limit (e.g: 85 dB).

Welding and Cutting Lens Shade Selector Guide

Current	MMA Electrodes	MIG Light Alloys	MIG Heavy Metals	MAG	TIG	Plasma Cutting	Plasma Welding	Air Arc Gouging	Current
10	8	10	10	10	9	11	11	10	10
15									15
20									20
30	9	10	10	10	10	11	11	10	30
40									40
60	10	10	10	10	11	11	11	10	60
80									80
100	11	11	11	11	12	12	12	10	100
125									125
150									150
175	12	12	12	12	13	12	13	11	175
200									200
225									225
250	12	13	12	13	13	12	13	11	250
275									275
300	13	14	13	14	14	13	14	12	300
350									350
400									400
450	14	15	14	15	15	13	14	13	450
500									500

SAFETY INSTRUCTION

Safety against fumes and welding gases



The HSE have identified welders as being an 'at risk' group for occupational diseases arising from exposure to dusts, gases, vapours and welding fumes. The main identified health effects are pneumonia, asthma, chronic obstructive pulmonary disease (COPD), lung and kidney cancer, metal fume fever (MFF) and lung function changes.

During welding and hot cutting 'hot work' operations, fumes are produced which are collectively known as welding fume. Depending upon the type of welding process being performed, the resultant fume generated is a complex and highly variable mixture of gases and particulates. Regardless of the length of welding being carried out, all welding fume, including mild steel welding requires suitable engineering controls to be in place which is usually Local Exhaust Ventilation (LEV) extraction to reduce the exposure to welding fume indoors and where LEV does not adequately control exposure it should also be enhanced by using suitable respiratory protective equipment (RPE) to assist with protecting against residual fume.

When welding outdoors appropriate RPE should be used.

Prior to undertaking any welding tasks an appropriate risk assessment should be carried out to ensure expected control measures are in place.

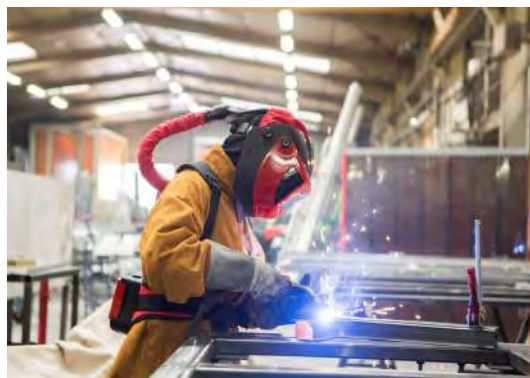

An example of personal fume protection

Locate the equipment in a well-ventilated position and keep your head out of the welding fume.

Do not breathe in the welding fume.

Ensure the welding zone is well-ventilated and provision should be made for suitable local fume extraction system to be in place.

If ventilation is poor, wear an approved airfed welding helmet or respirator.

Read and understand the Material Safety Data Sheets (MSDS's) and the manufacturer's instructions for metals, consumable, coatings, cleaners and de-greasers.

Do not weld in locations near any de-greasing, cleaning or spraying operations.

Be aware that heat and rays of the arc can react with vapours to form highly toxic and irritating gases.

For further information please refer to the HSE website www.hse.gov.uk for related documentation.

Precautions against fire and explosion



Avoid causing fires due to sparks and hot waste or molten metal.

Ensure that appropriate fire safety devices are available near the welding and cutting area.

Remove all flammable and combustible materials from the welding, cutting and surrounding areas.

Do not weld or cut fuel and lubricant containers, even if empty. These must be carefully cleaned before they can be welded or cut.

Always allow the welded or cut material to cool before touching it or placing it in contact with combustible or flammable material.

Do not work in atmospheres with high concentrations of combustible fumes, flammable gases and dust.

Always check the work area half an hour after cutting to make sure that no fires have begun.

Take care to avoid accidental contact of the torch electrode to metal objects, as this could cause arcs, explosion, overheating or fire.

Know and understand your fire extinguishers

Symbol found on fire extinguishers or what they mean	Water	Foam spray	ABC powder	Carbon dioxide	Wet chemical
Flammable Wood, paper & textiles (A)	✓	✓	✓	✗	✓
Flammable liquids (B)	✗	✓	✓	✓	✗
Flammable gases (C)	✗	✗	✓	✗	✗
Electrical contact (E)	✗	✗	✓	✓	✗
Cooking oil & fats (F)	✗	✗	✗	✗	✓

SAFETY INSTRUCTION

The working environment



Ensure the machine is mounted in a safe and stable position allowing for cooling air circulation.
Do not operate equipment in an environment outside the laid down operating parameters.
The welding power source is not suitable for use in rain or snow.

Always store the machine in a clean, dry space.

Ensure the equipment is kept clean from dust build up.

Always use the machine in an upright position.

Protection from moving parts



When the machine is in operation keep away from moving parts such as motors and fans.

Moving parts, such as the fan, may cut fingers and hands and snag garments.

Protections and coverings may be removed for maintenance and managed only by qualified personnel after first disconnecting the power supply cable.

Replace the coverings and protections and close all doors when the intervention is finished and before starting the equipment.

Take care to avoid getting fingers trapped when loading and feeding wire during set up and operation.

When feeding wire be careful to avoid pointing it at other people or towards your body.

Always ensure machine covers and protective devices are in operation.

Risks due to magnetic fields



The magnetic fields created by high currents may affect the operation of pacemakers or electronically controlled medical equipment.

Wearers of vital electronic equipment should consult their physician before beginning any arc welding, cutting, gouging or spot welding operations.

Do not go near welding equipment with any sensitive electronic equipment as the magnetic fields may cause damage.

Keep the torch cable and work return cable as close to each other as possible throughout their length.

This can help minimise your exposure to harmful magnetic fields.

Do not wrap the cables around the body.

Handling of compressed gas cylinders and regulators



Mishandling gas cylinders can lead to rupture and the release of high pressure gas.

Always check the gas cylinder is the correct type for the welding to be carried out.

Always store and use cylinders in an upright and secure position.

All cylinders and pressure regulators used in welding operations should be handled with care.

Never allow the electrode, electrode holder or any other electrically “hot” parts to touch a cylinder.

Keep your head and face away from the cylinder valve outlet when opening the cylinder valve.

Always secure the cylinder safely and never move with regulator and hoses connected.

Use a suitable trolley for moving cylinders.

Regularly check all connections and joints for leaks.

Full and empty cylinders should be stored separately.

Never deface or alter any cylinder

SAFETY INSTRUCTIONS

Fire awareness



The cutting and welding process can cause serious risks of fire or explosion. Cutting or welding sealed containers, tanks, drums or pipes can cause explosions. Sparks from the welding or cutting process can cause fires and burns. Check and risk assess the area is safe before doing any cutting or welding. Ventilate all flammable or explosive vapour from the workplace.

Remove any and all flammable materials away from the working area. If necessary, cover flammable materials or containers with approved covers (following manufacturers instructions) if unable to remove from the immediate area.

Do not cut or weld where the atmosphere may contain flammable dust, gas or liquid vapour. Always have the appropriate fire extinguisher nearby and know how to use it.

Hot parts



Always be aware that material being cut or welded will get very hot and hold that heat for a considerably long time which will cause severe burns if the appropriate PPE is not worn. Do not touch hot material or parts with bare hands.

Always allow for a cooling down period before working on material recently cut or welded. Use the appropriate insulated welding gloves and clothing to handle hot parts to prevent burns.

Noise awareness



The cutting and welding process can generate noise that can cause permanent damage to your hearing. Noise from cutting and welding equipment can damage hearing.

Always protect your ears from noise and wear approved and appropriate ear protection if noise levels are high.

Consult with your local specialist if you are unsure how to test for noise levels.

RF Declaration



Equipment that complies with directive 2014/30/EU concerning electromagnetic compatibility (EMC) and the technical requirements of EN60974-10 is designed for use in industrial buildings and not for domestic use where electricity is provided via the low voltage public distribution system.

Difficulties may arise in assuring class A electromagnetic compatibility for systems installed in domestic locations due to conducted and radiated emissions.

In the case of electromagnetic problems, it is the responsibility of the user to resolve the situation.

It may be necessary to shield the equipment and fit suitable filters on the mains supply.

LF Declaration



Consult the data plate on the equipment for the power supply requirements.

Due to the elevated absorbance of the primary current from the power supply network, high power systems affect the quality of power provided by the network. Consequently, connection restrictions or maximum impedance requirements permitted by the network at the public network connection point must be applied to these systems.

In this case, the installer or the user is responsible for ensuring the equipment can be connected, consulting the electricity provider if necessary.

SAFETY INSTRUCTION

Materials and their disposal



Welding equipment is manufactured with BSI published standards meeting CE requirements for materials which do not contain any toxic or poisonous materials dangerous to the operator.

Do not dispose of the equipment with normal waste.

The European Directive 2012/19/EU on Waste Electrical and Electronic Equipment states that electrical equipment that has reached its end of life must be collected separately and returned to an environmentally compatible recycling facility for disposal.

For more detailed information please refer to the HSE website www.hse.gov.uk

PACKAGE CONTENTS AND UNPACKING

Supplied within your new Weld Star Infinium product package will be the following items with each model.

Use care when unpacking the contents and ensure all items are present and not damaged.

If damage is noted or items are missing, please contact the supplier in the first instance and before installing or using the product.

Record the product model, serial numbers and purchase date in the information section found on the inside front page of this operating manual.

Weld Star WS-MU4-1 ACDC LCD

Weld Star MU4-1 Power Source

Titanium T240 3M MIG Torch (T240-3)

Titanium 26 Tig Torch 12ft (TIG-103)

MMA work lead

Work Return Lead

Gas Regulator

Gas Hose

0.8mm/1.0mm V feed roll

USB Stick including Operating Manual

Please Note:

- You may note that the package contains 2 spare brackets, if so, these are only required if you have or do purchase the Weld Star 2 wheel trolley WS-T2.
These brackets allow the MU4-1 machine to be secured to the trolley shelf.
- Package contents may vary depending on country location and package part number purchased.

PRODUCT OVERVIEW

The Weld Star MU4-1 is a true multi-process inverter welder offering professional welding performance in all processes and is the first of its kind to include pulse technology in MIG, TIG and MMA, making it the most versatile machine on the market today.

It has been designed to incorporate the most advanced features and technology offering the operator a user-friendly interface via the 5" true colour LCD display.

Welding process's include:

- ◆ MIG/MAG Synergic
- ◆ MIG/MAG Pulse
- ◆ MIG/MAG Standard
- ◆ TIG AC (HF/LIFT)
- ◆ TIG DC (HF/LIFT)
- ◆ MMA AC
- ◆ MMA DC

Weld Star Plasma WS-MU4-1 Product Features:

- Advanced IGBT multi-process inverter technology which is compact and lightweight at only 20kg
- PFC technology offering multiple advantages such as energy efficiency and wide range input voltage from 95Vac – 265Vac
- Wired and wireless remote control options
- Generator friendly
- Smart fan – reduces power consumption and intake of dust and fumes
- IP23 protection
- Built to EN-60974-1 and is fully compliant with the European Commission Regulation 2019/1784, CE and UKCA
- With synergic MIG/MAG, welding parameters can be automatically selected based on material thickness and voltage with synergic curves for common materials and wires
- Integrated TIG welding features such as HF or lift TIG, pre/post flow gas times, 2T/4T, slope up/down and pulse, all to ensure excellent TIG welding characteristics in both AC and DC
- SMART TIG function with advanced TIG welding features, such as multi-wave, Q start and hybrid TIG, whilst still maintaining ease of set up for the user
- DC and AC MMA suitable for a wide range of electrodes
- Advanced MMA features such as pulse and automatic current regulation based on electrode diameter
- Hot start arc ignition function which ensures excellent arc ignition in MMA for easier and more reliable arc starting
- Self adaptive arc force technology which maintains MMA arc conditions during operation even with long welding cables
- In-built VRD (MMA and TIG mode only)
- Designed for gas and gasless MIG welding wires.
- Ability to save up to 10 stored programs for quick set up
- Advanced error code menu for ease of fault and troubleshooting diagnosis
- Panel mounted USB connection for quick and easy firmware updates
- Available with a wide range of accessories including foot pedal, spool on gun and 2 wheel trolley



TECHNICAL SPECIFICATIONS

Parameter	Unit	Weld Star WS-MU4-1	
Rated input voltage	V	Wide Voltage 95Vac – 265Vac	
		AC110V (±15%) 50/60Hz	AC230V (±15%) 50/60Hz
Rated input power	kVA	4.5	7.5
Rated input current I _{max}	A	MIG 35 TIG AC 31.5 / DC 33 MMA AC 36.5 / DC 39.5	MIG 28 TIG AC 21 / DC 22.5 MMA AC 30.5 / DC 33.5
Rated input current I _{eff}	A	MIG 17.5 TIG AC 16 / DC 16 MMA AC 18.2 / DC 19.7	MIG 14 TIG AC 10 / DC 11 MMA AC 15 / DC 17
Welding current range	A	MIG 10 ~ 140 MMA 5 ~ 130 TIG 5 ~ 160	MIG 40 ~ 200 MMA 5 ~ 200 TIG 5 ~ 200
No-load voltage	V	MIG 28 MMA 75 TIG 75	
Rated duty cycle (40°C)	%	MIG 140A @ 25% MMA AC/DC 130A @ 25% TIG AC/DC 160A @ 25%	MIG 200A @ 25% MMA AC/DC 200A @ 25% TIG AC/DC 200A @ 25%
Efficiency	%	85	
Idle state power	W	30	
Power factor	cosφ	0.99	
Standard	-	EN60974-1	
Protection class	IP	IP23	
Insulation class	-	H	
Noise	db	<70	
Humidity	%	<90% (20°C)	
Operating temperature range	°C	-10 ~ +40	
Storage temperature	°C	-25 ~ +55	
MIG Torch	-	Titanium T240 3m	
MIG recommended wire size	mm	FE: 0.6/0.8/1.0 - SS: 0.8/1.0 - Flux Cored: 0.6/0.8/1.0	
Wire reel weight/spool size	kg/mm	5kg / 200mm	
MMA recommended electrode Size	mm	1.6 ~ 3.2	1.6 ~ 4.0
Overall size	mm	620 X 220 X 370 (without handle) 620 X 220 X 430 (with handle)	
Weight	kg	20	

CONTROLS

Front view Weld Star WS-MU4-1

1. Protective control panel cover
2. Control panel (see below and page 16 for further information)
3. Positive '+' Dinse socket outlet (35/50mm)
4. MIG Torch outlet connector, the connection that allows for a euro style MIG torch to be fitted
5. 9 Pin remote control socket (12 pin on early models) see page 61 for further information
6. Cooling air vent
7. TIG gas outlet (10mm)
8. Negative '-' Dinse socket outlet (35/50mm)

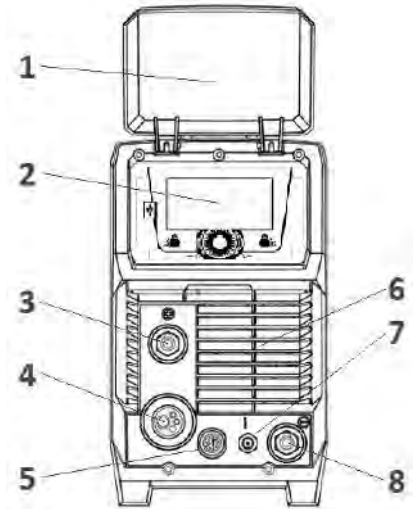

Rear view Weld Star WS-MU4-1

9. Protective control panel cover
10. Carry handle
11. Gas inlet
12. Air vent
13. Mains power ON/OFF switch
14. Mains input power cable

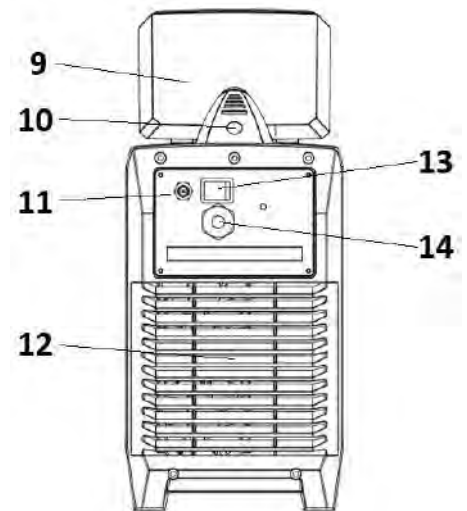

Control panel view Weld Star WS-MU4-1

27. USB Connector *
28. 5" Digital screen
29. Left control button
30. Main control dial and activation button
31. Right control button

* The front panel USB socket allows for easy software updates to be loaded into the machine. By inserting a 'loaded' Weld Star USB while the machine is turned off and then switching the machine ON will the machine automatically load the updated firmware and programs (during this mode the screen displays the firmware update status). Once the update is complete the machine will boot up as normal.



CONTROLS

Side view Weld Star WS-MU4-1

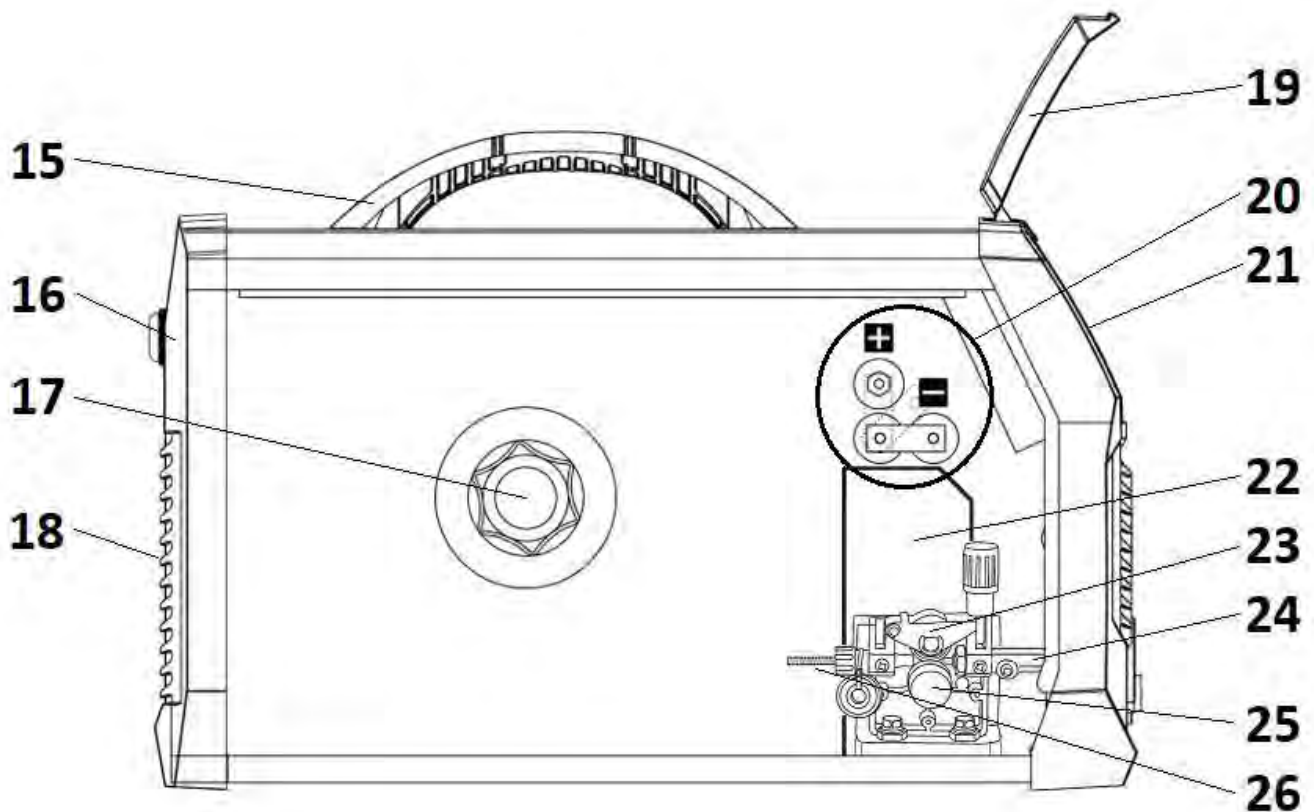

15. Carry handle
16. Rear panel (see page 12 for further information).
17. Wire spool holder and tensioner: Allows a 5kg (200mm diameter) reel of wire to be located in place via an alignment pin and then locked in place with the locking nut. The spool holder also has a brake arrangement to ensure correct tension of the wire, this is done by turning the central bolt with an allen key clockwise (to tighten) or anti clockwise (to loosen).
18. Rear air vent.
19. Protective control panel cover.
20. Adjustment point to euro MIG torch outlet polarity to be either positive '+' or negative '-'.
When using gas set the connection to '+' when using 'gasless' welding wire set the connection to '-'.
21. Control panel (see page 12 and from page 16 for further information).
22. Drive Assembly feed motor and gearbox (the feed motor is located behind the plastic cover).
23. Upper pressure roll assembly: Holds the upper drive roll in place which applies pressure to the welding wire via the fitted grooved drive roll, the pressure is applied via the drive roll tensioner which allows the correct amount of tension to be applied to the top roller to ensure good feed of the wire through the MIG torch.
24. Outlet feed adaptor: Part of the Euro outlet connector assembly which contains the inner outlet guide which ensures smooth wire feed from the drive assembly through to the MIG torch.
25. Wire feed roller and retaining nut. Secures and holds the grooved drive roll in place.
The feed roll supplied with the machine is a 0.8mm/1.0mm V
26. Inlet wire guide: The welding wire is fed through the inlet guide prior to feeding through the drive rollers.

INSTALLATION

Unpacking

Check the packaging for any signs of damage.

Carefully remove the machine and retain the packaging until the installation is complete.

Location

The machine should be located in a suitable position and environment. Care should be taken to avoid moisture, dust, steam, oil or corrosive gases.

Place on a secure level surface and ensure that there is adequate clearance around the machine to ensure natural airflow.

Input connection

Before connecting the machine you should ensure that the correct supply is available. Details of the machine requirements can be found on the data plate of the machine or in the technical parameters shown in the manual.

The equipment should be connected by a suitably qualified competent person. Always ensure the equipment has a proper grounding.

Never connect the machine to the mains supply with the panels removed.

Output connections

Electrode polarity

In general when using manual arc welding electrodes the electrode holder is connected to the positive terminal and the work return to the negative terminal. Always consult the electrode manufacturer's data sheet if you have any doubts.

MMA welding

Insert the cable plug with electrode holder into the "+" socket on the front panel of the welding machine and tighten it clockwise.

Insert the cable plug of the work return lead into the "-" socket on the front panel of the welding machine and tighten it clockwise.

INSTALLATION

MIG welding

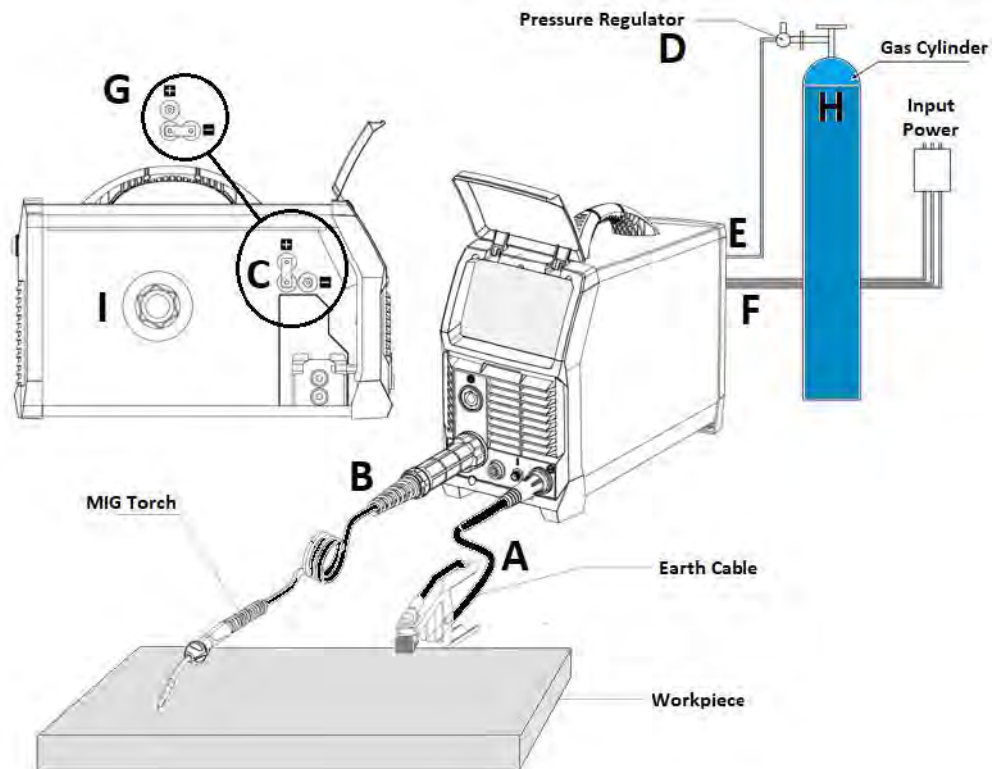

- Insert the welding torch (B) into the “Euro connector for torch in MIG” output socket on the front panel of the machine and tighten it into position.
- Insert the work return lead cable plug (A) into the “-” output terminal of the welding machine and tighten by rotating it clockwise.
- Ensure that the link (C) the torch polarity connection link is in the vertical position and connected to the “+” terminal, this ensure that’s the MIG torch polarity is positive (+).
- Install the welding wire on the spindle adapter (I).
- Connect the cylinder (H) equipped with the gas regulator (D) to the gas inlet on the back panel of the machine (E) with a gas hose.
- Ensure that the wire groove size of the fitted drive roll matches the contact tip (fitted to the MIG torch) and the welding wire size being used.
- Release the pressure arm of the wire feeder to thread the wire through the guide tube and into the drive roll groove and then adjust the pressure arm, ensuring no sliding of the wire. (too much pressure will lead to wire distortion which will affect wire feeding).
- Turn the machine ON
- Via the user display, place the welding mode function into the MIG position (see page 16).
- ‘Inch’ the welding wire through the MIG torch and out via the contact tip (see page 16).
- You are now ready to start MIG welding.

Gasless self shielded MIG welding

When carrying out MIG welding with gasless welding wire the welding torch polarity is reversed, so the MIG torch is ‘-’ and the work return lead is ‘+’

Follow the above procedure except for the following:

- Insert the work return lead cable plug (A) into the “+” output terminal of the welding machine and tighten by rotating it clockwise.
- Ensure that the link (G) the torch polarity connection link is in the horizontal position and connected to the “-” terminal, this ensure that’s the MIG torch polarity is now negative (-).
- Ensure that you have turned OFF the gas supply at the cylinder.

MULTIFUNCTIONAL DISPLAY WINDOW

Display Screen Explained WS-MU4-1

Upon powering ON your MU4-1 and boot up sequence is complete, the main menu will appear on the LCD digital screen 'F' as shown right, this allows the operator to navigate the various welding processes by rotating the control dial 'B' clockwise or anti clockwise and when the desired option is front and centre then you can press the dial 'B' to access the required welding mode.

Along with the settings option you can also navigate yourself through the welding modes that include: MMA, MIG Pulse, MIG Synergic, MIG Standard, Lift TIG, HF TIG and Smart TIG.

Button 'A' is usually associated with the icon that's circled 'D' (to access option short press A). Button 'C' is usually associated with the icon that's circled 'E' (to access option short press C).



Navigate to one of the MIG welding process options, the example shown left is MIG manual, you will then note that just above the control dial circled 'H' it shows the polarity of the MIG torch and work return lead:

- MIG torch symbol is '+' (positive polarity)
- Work return lead clamp is '-' (negative polarity)

To check that the outputs are configured correctly, please check out pages 15-16 to adjust and set if required.

In this screen you also have the ability to check and activate gas purge along with 'inching' the wire feed.

- If you long press and release button 'A' (approx. 3 seconds) the gas solenoid will activate allowing the gas to purge and flow, allowing you to test and set the gas flow accordingly.
- If you long press and release button 'C' (approx. 3 seconds) this activates the wire feed motor which in turn pushes the welding wire through the MIG torch and contact tip.

If you press the control dial 'B' button, this will take you to the MIG manual welding process control screen, as shown left, where you can adjust (in this case being MIG Manual) the following settings:



- 1 Wire Feed Speed
- 2 Welding Voltage
- 3 MIG Torch switch control, 2T, 4T, S4, Spot and S2t
- 4 Variable MIG Inductance control

To access these advanced setting, press the control dial 'B' and each of the green circled parameters numbered 1 - 4 will highlight red in turn as you rotate the control dial B.

To adjust a highlighted parameter, press the control dial which will allow you to adjust selected parameter by rotating the dial and then pressing the control dial again will store the parameter setting and automatically move to the next parameter option.

Please Note: Parameter options vary depending on welding process and torch trigger mode selected.

MULTIFUNCTIONAL DISPLAY WINDOW

Display Screen Explained WS-MU4-1 (continued)

As previously noted buttons A and C have 2 functions determined by either a short or long press of buttons A and C.

- Briefly pressing buttons A or C will activate the 2 option icons circled purple.
- Pressing, holding the releasing buttons A and C for approx. 3 seconds will activate the 2 option circled in green (save and load in this case).



Following on from the instructions on the previous page, if you press and release (short press) button 'C' you will now enter a new screen (shown left) that allows the operator to select and adjust more advanced (in this case) MIG settings such as:

- Pre gas flow
- Slope up
- Current
- Slope down
- Post gas flow
- Burn back
- Also Start Amps, Start Amps time and final amps are available in either S2t or S4t torch trigger mode.

Please Note: These parameter options do change depending on which welding process and torch trigger mode you have selected.

Save and Loading welding programs

The following information details the save and load options of welding parameters as detailed below:



Saving a welding program

If you long press (approx. 3 seconds) and release button 'A' the screen will change to the memory save option.

As you will see this screen allows the operator to save his setup to 1 of 10 memory programs.

To save, rotate the control dial to the desired program number and then press and release button 'C'.



Loading a welding program

If you long press and release button 'C' (for approx. 3 seconds) the screen will change to the memory load option.

This screen allows the operator to load previously saved welding programs.

To load a program, rotate the control dial to the desired program number and then press and release button 'C'

You will then return to the loaded welding program screen.

OPERATION - MIG/MAG



Before starting any welding activity ensure that you have suitable eye protection and protective clothing. Also take the necessary steps to protect any persons within the welding area.

MIG/MAG welding mode

MIG - Metal Inert Gas Welding, MAG - Metal Active Gas Welding, GMAW - Gas Metal Arc Welding

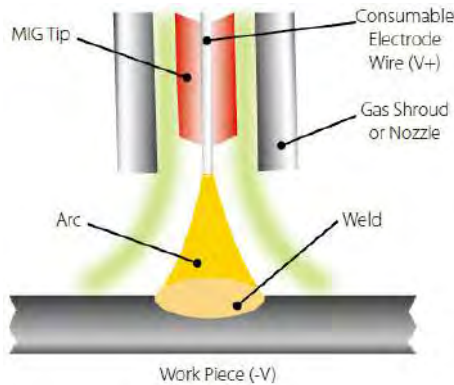

MIG welding was developed to help meet production demands of the war and post war economy which is an arc welding process in which a continuous solid wire electrode is fed through a MIG welding gun and into the weld pool, joining the two base materials together.

A shielding gas is also sent through the MIG welding gun and protects the weld pool from contamination which also enhances the arc.

Connect the MIG torch as shown (B)
Work return lead to '-' (A)

Ensure that a suitable inert gas supply is connected (E).

Switch the power switch on the back panel to "ON" (F) the machine is started with the panel display coming ON.

Via the display navigate to welding mode and set welding mode to MIG or MIG synergic depending on your application.

Open the gas valve of the cylinder and adjust the gas regulator to obtain the desired flow rate (D).

Adjust the displays MIG settings on the machine control panel to get the correct desired welding condition of welding voltage, current etc (see page 17 for further info on the control panel display function)

Operate the torch trigger and welding can be carried out, (Note: Once the MIG torch switch is pressed, if no welding current is sensed within 5 seconds, wire feed, gas and output voltage will stop).

The below MIG wire guide can vary depending on material used, work piece thickness, welding position and joint form.

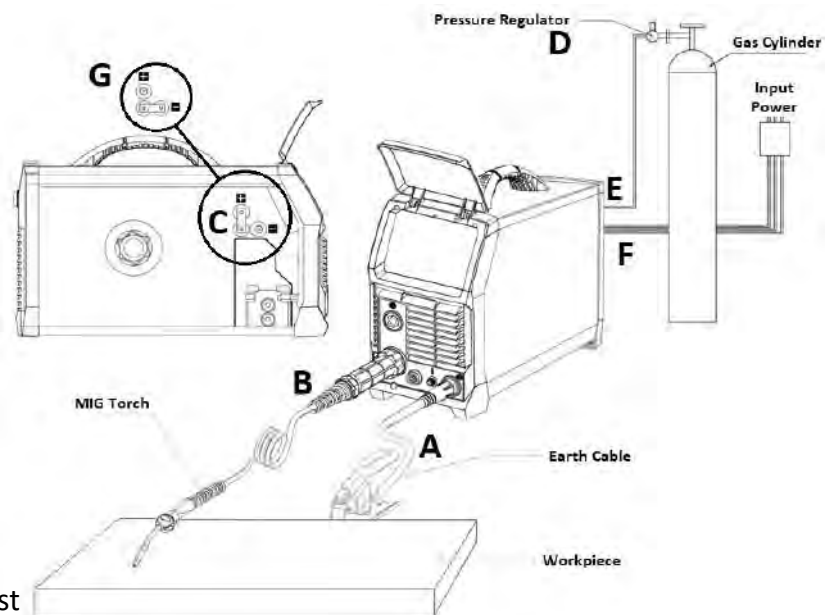

MIG - Gasless Welding

The operation method is the same as the above MIG operation except there are no gas options and the output polarity is reversed (G in above image).

Wire Diameter (mm)	DIP Transfer		Spray Transfer	
	Current (A)	Voltage (V)	Current (A)	Voltage (V)
0.6	30 ~ 80	15 ~ 18	n/a	n/a
0.8	45 ~ 180	16 ~ 21	150 ~ 250	25 ~ 33
1.0	70 ~ 180	17 ~ 22	230 ~ 300	26 ~ 35
1.2	60 ~ 200	17 ~ 22	250 ~ 400	27 ~ 35
1.6	100 ~ 280	18 ~ 22	250 ~ 500	30 ~ 40

Please Note:

Before starting any welding activity ensure that you have suitable PPE including eye protection and protective clothing. Also consider and take the necessary steps to protect any persons within the area.

MULTIFUNCTIONAL DISPLAY WINDOW - MIG MODE

Welding screen/display explained MU4-1



Upon powering ON your WS-MU4-1 and boot up is complete, the control panels main menu will appear on the digital panel as shown above.

You can now navigate yourself through the various options and welding modes which include: Settings, MIG Pulse, MIG Synergic, MIG Manual, Lift TIG, HF TIG, Smart TIG and MMA.

In the home screen, for MIG welding the following options are available:



MIG Pulse

MIG Synergic

MIG Manual

By rotating the main centre control dial you will 'scroll' through the options and by pressing the dial you will enter either MIG Pulse, MIG Synergic or MIG manual mode.

Conventional MIG welding equipment (MIG manual) run at a steady single amperage where the operator has access and controls of the wire feed speed rate and the welding voltage whereas with MIG pulsed welding the machine runs a peak and a background amperage and the unit will constantly switch between the two amperages enabling the operator to put out a lower overall heat input into the material. One of the benefits of MIG pulse includes smoother spatter free welding to help prevent blowing through thin material.

When MIG synergic welding is referred to it means that when a single setting is adjusted (voltage or material thickness) the other settings like current or wire speed change automatically.

Please Note:

When in the selection screens (as above) for MIG welding modes, pressing and holding either the bottom left or the bottom right buttons will give you the facility of 'Gas Test' or 'Wire Feed Inch' which are noted in the top line of the display.

MULTIFUNCTIONAL DISPLAY WINDOW - MIG MODE

Welding screen/display explained MU4-1

When selecting either MIG pulse or MIG Synergic mode, the operator has the option to select material, gas and wire size as shown below, this selection is carried out by rotating and pressing the main dial to select the desired option.

Material selection choice is as follows:

- FE - Mild Steel
- Flu.Fe - Flux Cored
- Ss - Stainless Steel
- AlMg - Aluminium Magnesium

Gas selection choice is as follows:

- 80% Ar 20%CO2
- 100% CO2

Wire diameter size selection choice is as follows:

- 0.6mm (0.024)
- 0.8mm (0.032)
- 0.9mm (0.035)
- 1.0mm (0.039)



At this point the bar along to bottom of the screen does show the operator welding mode, material, gas and wire size that have selected.

Once you have selected the key welding setup parameters as shown above, you will now enter the main welding screen that displays centrally your chosen MIG process, material, gas and wire size.



As the above screens show, the left circular section offers either current or wire feed setting and the right section shows voltage/arc length and these options can vary depending on which MIG process has been selected.

The bottom row shows, material thickness, torch trigger mode and inductance control and to adjust each setting, simply press the control dial until the parameter you wish to adjust is highlighted in red and then rotate the dial to adjust said parameter, pressing the control dial again stores that parameter setting.

When in Pulse MIG you have an additional feature called 'Wire retract' which is only effective when welding aluminum material. When 'Wire Retract' is set it ON (see page 60), at arc starting the welding wire will briefly retract when first touching the workpiece and the initial start current is lowered to enhance weld starting properties. When set to OFF the 'Wire Retract' feature will not be active.

MULTIFUNCTIONAL DISPLAY WINDOW - MIG MODE

Welding screen/display explained MU4-1



When selecting MIG manual, you will be taken directly to the welding screen shown left.

Now the left circular section offers just wire feed speed control and the right section shows voltage control, while the bottom row shows torch trigger mode and inductance control.

Again, to adjust each setting, simply press the control dial until the parameter you wish to adjust is highlighted in red and then rotate the dial to adjust said parameter, pressing the control dial again stores that parameter setting.

However depending on which MIG mode you have selected, further welding parameters are available and adjustable by following the next steps.

The selection and setting of advanced welding parameters can be carried out in the welding interface screen by pressing the bottom right button to enter the welding parameter setting interface;

In this welding parameter setting interface, press the control dial to select the parameter as required and rotate the dial to set a value for the selected parameter.



You will note from the above images that the selected parameter being adjusted is Pre-Flow Gas and the bottom bar shows the min setting (0.0) and the max setting of (20) seconds with the lines between going up/down depending where you set the adjustment rotating dial.

Depending on welding process and torch trigger selection, welding parameters options available	Unit	Welding parameters range available by rotating the dial
Pre-flow	Seconds	0 ~ 20
Slow feed	Mm/min	0 ~ 10
Start current	%	1 ~ 200
Start current (arc length)	A	-10 ~ +10 (Pulse mode only)
Up Slope	Seconds	0.0 ~ 20
Welding Current Range	A	25 ~ 110 (110V) / 25 ~ 200 (230V)
Down Slope	Seconds	0 ~ 20
End Amp (current)	%	1 ~ 200
Final current (arc length)	-	-10 ~ +10 (Pulse mode only)
Burn Back	Seconds	0 ~ 10
Post-flow	Seconds	0 ~ 20
Wire Retract	-	ON or OFF

Please Note:

- The above listed parameter options do change depending on which welding process and torch trigger mode you have selected.
- When in S2t and S4t trigger modes, the MIG Pulse and Synergic adjustable settings (as shown above) will offer additional changeable parameter that can be adjusted to suit the operator preferences.

MULTIFUNCTIONAL DISPLAY WINDOW - MIG MODE

Welding screen/display explained MU4-1

When selecting MIG mode you can select various trigger modes noted within the red circles below. Navigate to and highlight the lower bar central option (as circled below) as shown as 4T trigger mode.



Depending on which welding mode you are in, will determine which options you can select.

As with previous pages, to select a different trigger option, press the control dial until the 4T trigger (as in the case the above images show) is highlighted red and then rotate the dial to select with trigger option you require, pressing the control dial again stores that parameter selection.

2T: normal trigger control

In this mode the torch trigger must remain depressed for the welding output to stay active. Press and hold the torch trigger to activate the power source (weld) then release the torch trigger to stop the welding process.

4T: latch trigger control

4T (latch) mode is mainly used for long welding runs to reduce operator finger fatigue. In this mode the operator can press the torch trigger, start the weld process and then release the torch trigger and welding will remain active.

To stop welding, the trigger switch must again be depressed and released. This function eliminates the need for the operator to hold the torch trigger.

Spot weld mode

When spot is selected, this offers the operator a pre-determined time for the weld time to be active. Once selected, to adjust the spot weld time you must first access the advanced parameter feature screen (by pressing bottom right control button when in the above screen) then rotate the control knob until the spot icon (top right) is highlighted, then pressing the control knob allows you to adjustment the spot welding time. Spot time is adjustable between 0.5 ~ 20 seconds.

S2t: Special 2T control

Different from normal 2T, you can set 'Start Current Percent' and 'Start Current Time' in S2t mode. If you press the gun torch, output current will start from the 'Start Current' and become 'Peak Current' after the 'Start Current Time'. This function is useful when welding aluminium. To access S2t the feature, please see page 21.

S4t: Special 4T control

In S4t mode, you can set 'Start Current Percent' and 'End Current Percent'. If you press the gun torch first time, output current will start from the 'Start Current'. Next if you release the gun torch, current will become 'Peak Current', next if you press the gun torch again, current will become 'End Current'. To access S4t feature, please see page 21.

Please Note: The Wire Retract function works in S2t and S4t mode (see page 20 for further details)

OPERATION - TIG



Before starting any welding activity ensure that you have suitable eye protection and protective clothing. Also take the necessary steps to protect any personnel within the welding area.

TIG welding mode

Terms used: TIG – Tungsten Inert Gas, GTAW – Gas Tungsten Arc Welding.

TIG welding is an arc welding process that uses a non-consumable tungsten electrode to produce the heat for welding.

The weld area is protected from atmospheric contamination by a shielding gas (usually an inert gas such as argon or helium) and a filler rod matching the base material is normally used, though some welds, known as autogenous welds, are carried out without the need for filler wire.

Connect the TIG torch power connection to the “-” dinse connector and fully tighten clockwise. Also connect the torch trigger plug and gas connection to the relevant connections on the front panel.

Insert the work return lead cable plug for the work clamp into the “+” dinse socket on the front panel of the welding machine and fully tightened clockwise.

Connect the gas hose to the regulator/flowmeter located on the shield gas cylinder and connect the other end to the machine.

Before starting any welding activity ensure that you have suitable PPE Including eye protection and protective clothing. Also consider and take the necessary steps to protect any persons within the area.

Now you will need to switch the power switch on the back panel to “ON”

Access the welding mode choice option via the digital display on the user control panel and then select the TIG mode option, you will also have the choice to choose either HF or lift TIG function.

Set the required amperage (along with other TIG parameter functions) via the digital control panel suitable for the application and TIG tungsten being used (see below guide).

Ensure you have adequate welding current according to the thickness of the work and weld prep being carried out and filler wire being used.

Open the gas valve of the cylinder, press the torch trigger and adjust the gas regulator to obtain the desired flow rate.

Once welding is complete release the torch trigger switch which will stop the welding arc but ensure you leave the torch in place to shield the weld with gas for a few seconds until the preset post flow gas turns off.

Please see page 22 for further parameter control options for TIG welding.

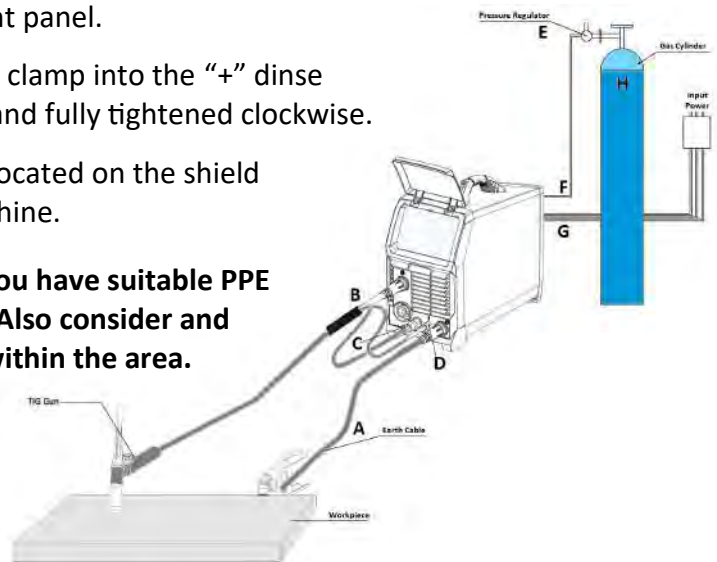
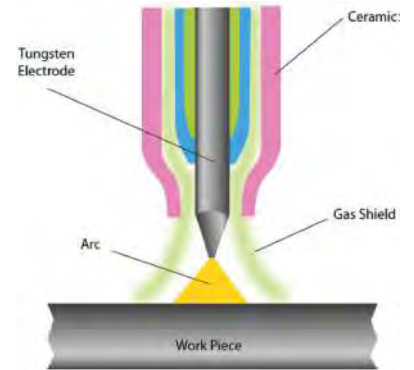

Tungsten Size	DC – Electrode Negative
1.0mm	15 – 80A
1.6mm	70 – 150A
2.4mm	150 – 250A
3.2mm	250A – 400A

MULTIFUNCTIONAL DISPLAY WINDOW - TIG MODE

Welding screen/display explained MU4-1



Upon powering ON your MU4-1 and boot up is complete, the control panels main menu will appear on the digital panel as shown above.

You can now navigate yourself through the various options and welding modes which include: Settings, MIG Pulse, MIG Synergic, MIG Manual, Lift TIG, HF TIG, TIG and MMA.

In the home screen, for TIG welding the following options are available:



By rotating the main centre control dial you will 'scroll' through the options and by pressing the dial you will enter either Lift TIG, HF TIG or Smart TIG.

Once you have selected either of the above TIG options you will then be able to navigate further options of DC, AC along with various AC waveforms, Pulse, slope, 2T/4T and many more.

The following pages will explain this in a little more details.

MULTIFUNCTIONAL DISPLAY WINDOW - TIG MODE

Welding screen/display explained MU4-1

When selecting LIFT TIG or HF TIG, you will be taken directly to the welding screen shown below.



Note that the left circular section offers TIG welding current control and the right section shows TIG voltage, while the bottom row shows Pulse, torch trigger mode and DC/AC output selection.

Again, to adjust each setting, simply press the control dial until the parameter you wish to adjust is highlighted in red and then rotate the dial to adjust said parameter, pressing the control dial again stores that parameter setting.

However, when selecting Smart TIG Mode which gives the operator the options to select Material, Joint Type and Material Thickness as shown below, this selection is carried out by rotating and pressing the main dial to select the desired option.

Material type selection choice is as follows:

- FE - Mild Steel
- SS - Stainless Steel
- Al - Aluminium

Joint Type choice is as follows:

- Butt Joint
- Fillet Joint
- Lap Joint

Material thickness selection choice is as follows:

- 1.0mm (0.039in)
- 1.5mm (0.059in)
- 2.0mm (0.079in)
- 2.5mm (0.098in)
- 3.0mm (0.119in)



At this point the bar along to bottom of the screen will update showing the operator material, welding joint and material thickness selected and once the 3rd option is selected you will switch to the screen shown right.

Within this screen, the left circular section offers TIG welding current control and the right section shows TIG voltage, while the bottom row (left to right) shows Tungsten size, gas mix with recommended gas flow rate, 2T torch trigger mode, recommended filler wire size, DC output and pulse being OFF.



To adjust each setting, press the control dial until the parameter you wish to adjust is highlighted in red, then rotate the dial to adjust said parameter, pressing the control dial again stores that parameter setting.

MULTIFUNCTIONAL DISPLAY WINDOW - TIG MODE

Welding screen/display explained MU4-1

Whether you have previously selected LIFT TIG, HF TIG or Smart TIG, the selection and setting of advanced welding parameters can be carried out in the welding interface screen by pressing the right button to enter the welding parameter setting interface.

In this welding parameter setting interface, pressing the control dial will select the various parameter in turn and once the required parameter is highlighted in red, rotate the dial to set a value for the selected parameter.

You will note from the image right that the selected parameter being adjusted is Start Amps and you will also note that the bottom bar shows the minimum setting (0.0) and a maximum setting of (200) amps with the variable red bar between going up/down depending where you set the adjustment rotating dial.



Additional TIG features

As with the above, whether you have selected LIFT TIG, HF TIG or Smart TIG, AC or DC, the option of further advanced welding parameters are possible, the following parameters which can be accessed via the welding interface screen by pressing the bottom right button to enter the welding parameter setting interface screen.

In this welding parameter setting interface, pressing the control dial will select the various parameter in turn and once the required parameter is highlighted in red, rotate the dial to set a value for the selected parameter.

Depending on welding process and torch trigger selection, welding parameters options available	Unit	Welding parameters range available by rotating the dial
Pre-flow	Seconds	0 ~ 20
Start current	A	1 ~ 200
Up Slope	Seconds	0 ~ 20
Down Slope	Seconds	0 ~ 20
End current	A	1 ~ 200
Post-flow	Seconds	0 ~ 20
Duty	%	5 ~ 95
Frequency	Hz	0.5 ~ 999
Balance	-	-5 ~ +5
AC Frequency	Hz	50 ~ 250
Base Amps	A	10 ~ 200
Spot Time	S	0.1 ~ 10
Tungsten size choice	mm	1 ~ 4
Q Start (DC TIG only)	S	0 ~ 60
Dynamic Arc (DC TIG only)	A	0 ~ 50
Multitack (DC TIG only)	Hz	0 ~ 6
Extra Fusion (AC TIG only)	%	0 ~ 80
Mix AC/DC (AC TIG only)	%	0 ~ 80

Please Note: The listed advanced parameter options do change depending on which welding process and torch trigger mode you have selected and the below shows the parameters adjustable range.

MULTIFUNCTIONAL DISPLAY WINDOW - TIG MODE

Welding screen/display explained MU4-1

Depending on which welding mode you are in, will determine which options you can select.

As with previous pages, to select a different trigger option, press the control dial until the 2T trigger mode (shown in the image right) is highlighted red and then rotate the dial to select with trigger option you require, pressing the control dial again stores that parameter selection.



2T: normal trigger control

In this mode the TIG torch trigger must remain depressed for the welding output to stay active. Press and hold the torch trigger to activate the power source (weld) then release the torch trigger to stop the welding process.

4T: latch trigger control

4T (latch) mode is mainly used for long welding runs to reduce operator finger fatigue. In this mode the operator can press the TIG torch trigger, start the weld process and then release the torch trigger and welding will remain active.

To stop welding, the trigger switch must again be depressed and released.

This function eliminates the need for the operator to hold the torch trigger.

Repeat Trigger Mode

The repeat function is operated during the down slope cycle of the Slope Sequence and is active through the down slope period only. During the down slope period by opening the TIG torch Switch the current will increase back to weld current. Within the Down Slope period the repeat function can be operated as many times as required.

To continue slope cycle and end slope sequence keep the torch switch pressed and allow weld current to reach final current setting.

Once final current setting is reached depressing the TIG torch switch again will turn OFF the welding arc and post flow begins.

Spot weld mode

When spot is selected, this offers the operator a pre-determined time for the weld time to be active.

Once selected, to adjust the spot weld time you must first access the advanced parameter feature screen (by pressing the bottom right control button when in the above screen) then rotate the control knob until the spot icon (top right) is highlighted, then pressing the control knob allows you to adjustment the spot welding time.

Spot time is adjustable between 0.1 ~ 10 seconds.

MULTIFUNCTIONAL DISPLAY WINDOW - TIG MODE

Welding screen/display explained MU4-1

Additional TIG features continued

MIX AC/DC

AC wave in AC/DC, this parameter serves to set the AC wave percentage with respect to the DC current output.

The consequences of a higher value:

- Greater weld penetration.
- Less deformation.
- Faster creation of the weld pool.
- Reduced cleanliness of the workpiece.
- Loss of arc



EXTRA Fusion

This parameter establishes the percentage of the positive current wave (pickling) that is subtracted and added to the negative current (fusion).

The image right shows the positive wave interval ΔI that, if subtracted and added to the negative wave, forms the new form of broken line wave.

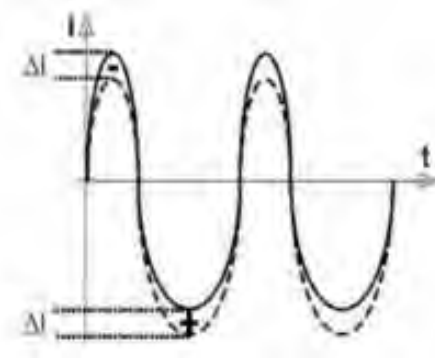

The consequences of a higher value:

- Tighter arc.
- Greater weld penetration.
- Reduced pickling.
- Loss of arc.
- Less deformation of the electrode.

Q-Start

This parameter allows the unit to start in synergic pulsed TIG mode for the preset time interval, before switching automatically to the welding Mode parameters already selected on the interface panel.

The Q-start parameter creates a weld pool faster with respect to the standard starting procedure. This parameter is useful when spot welding thin gauge material.



Dynamic ARC

Welding power remains constant even when the distance between electrode and workpiece changes, the consequences of a higher value are:

- The welding arc concentration remains unchanged.
- Prevents electrode sticking.
- Thin workpieces may become deformed more easily.

Multitrack

This parameter allows thin gauge sheet to be welded without deformation, the consequences of a higher value:

- Welding of thinner gauge sheet without deformation.
- Less melting of material, slower welding process.

OPERATION - MMA



Before starting any welding activity ensure that you have suitable eye protection and protective clothing. Also take the necessary steps to protect any personnel within the welding area.

MMA welding mode

MMA (Manual Metal Arc), SMAW (Shielded Metal Arc Welding) or just Stick Welding.

Stick welding is an arc welding process which melts and joins metals by heating them with an arc between a covered metal electrode and the work.

Shielding is obtained from the electrode outer coating, often called flux. Filler metal is primarily obtained from the electrode core.

The electrodes outer coating called flux assists in creating the arc and provides a shielding gas and on cooling forms a slag covering to protect the weld from contamination.

When the electrode is moved along the work piece at the correct speed the metal core deposits a uniformed layer called the weld bead.

After connecting the welding leads as detailed you will need to switch the power switch on the back panel to "ON".

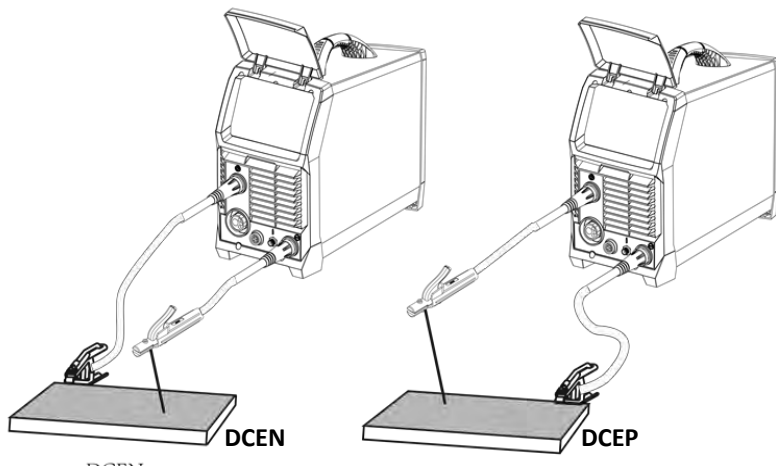
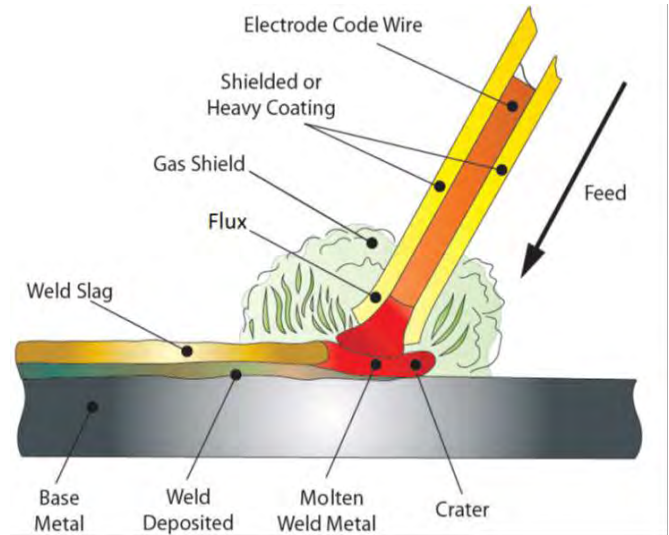

Using the control display navigate to the MMA mode, select MMA by switching to the MMA position. There is now open circuit voltage output at both output terminals, (see page 26 for further info on the control panel display function).

Ensure you check that you have the electrode polarity correct (See image left).

Set the amperage on the machine suitable for the electrode being used.

Please see the below a guide to amperages required, although MMA welding electrode guide can vary depending on material, work piece thickness, welding position and joint form.

Please Note:

Before starting any welding activity ensure that you have suitable PPE including eye protection and protective clothing.

Also consider and take the necessary steps to protect any persons within the area.

Electrode Diameter (mm)	Recommended Welding Current (A)
1.6	25 ~ 45
2.0	35 ~ 65
2.5	50 ~ 90
3.2	60 ~ 130
4.0	100 ~ 180
5.0	150 ~ 250
6.0	200 ~ 310

MULTIFUNCTIONAL DISPLAY WINDOW - MMA MODE

Welding screen/display explained MU4-1



Upon powering ON your MU4-1 and boot up is complete, the control panels main menu will appear on the digital panel as shown above, rotate the control dial until the MMA welding option is center and then press the dial to access this welding mode.

In the image right you can see how the MMA screen setup, the left dial is the preset welding amperage and in the right dial shows the associated welding voltage and in the centre it shows the selected MMA electrode size (3.2mm in this case).

The bottom row shows MMA pulse ON/OFF, welding electrode diameter and choosing between DC or AC welding output.

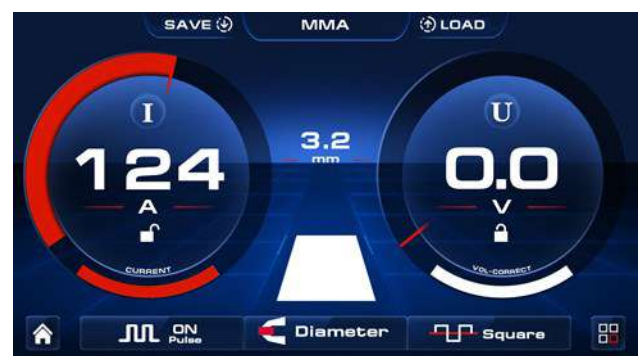

From this screen you can also select and control advanced MMA welding parameters via the icon  by pressing the right button to enter the welding parameter setting interface.

The following page will explain this in a little more detail.

MULTIFUNCTIONAL DISPLAY WINDOW - MMA MODE

Welding screen/display explained MU4-1

MMA Welding parameter adjustments

The image to the right shows the process flow of MMA welding, Hot Start current with hot start time, if AC is selected then AC frequency and AC duty is adjustable as shown as well as other parameters.

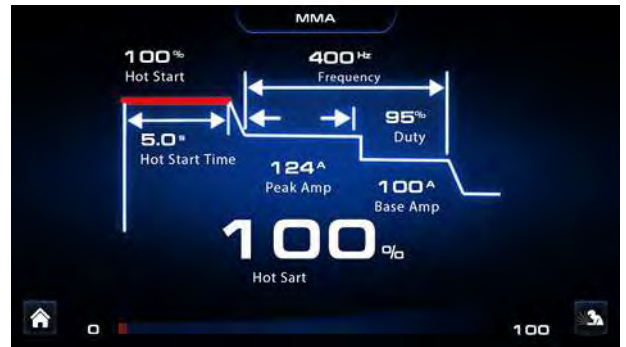

You will note from the image right that the selected parameter being adjusted is Hot Start and you will also note that the bottom bar shows the minimum setting (0) and the maximum setting of (100) % with the variable red bar between going up/down depending where you set the adjustment rotating dial.

In this welding MMA parameter setting interface, pressing the control dial will select the various parameter in turn and once the required parameter is highlighted in red, rotate the dial to set a value for the selected parameter.

Please Note:

The above shown advanced parameter screen options and the listed below do change depending on whether AC or DC have been selected along with pulse being ON or OFF.

The chart below shows some of the parameters available and there adjustable range.

Accessible welding parameters	Unit	Parameters range
Hot start	%	0 ~ 100
Hot start time	Seconds	0.5 ~ 5.0
Arc force	A	0 ~ 100
Duty	%	5 ~ 95
Frequency	Hz	0.5 ~ 400
Peak Amp	A	10 ~ 110 (110V input) 10 ~ 200 (230V input)
Base Amp	A	10 ~ 110 (110V input) 10 ~ 200 (230V input)

VRD

Voltage Reduction Device is an in-built electrical circuit which is used in the MMA mode to reduce the OCV to a safe voltage of less than 13V when the machine is in idle.

Activating VRD

Press and hold together for approx. 3 seconds buttons A and C, then release. You will then be taken to the 'hidden' VRD screen that allows the user to turn VRD ON or OFF by rotating the control dial clockwise or anti clockwise to turn VRD ON or OFF.

Upon selecting your required status, press button A which will save the VRD setting and return you to the MMA welding mode screen.



Upon returning to the MMA screen you will now note that the U (OCV) voltage is now under 13V and located centrally it states that VRD is ON (as shown left).

GUIDE TO MIG/MAG WELDING



Before starting any welding activity ensure that you have suitable eye protection and protective clothing. Also take the necessary steps to protect any personnel within the welding area.

MIG process description

The MIG process was first patented for the welding of aluminium in 1949 in the USA.

The process uses the heat that is generated by an electric arc formed between a bare consumable wire electrode and the work piece.

This arc is shielded by a gas to prevent oxidation of the weld.

In the MIG process an inert shielding gas is used to protect the electrode and weld pool from contamination and enhance the arc. Originally this gas was helium.

In the early 1950's the process became popular in the UK for welding aluminium using argon as the shielding gas.

Development in the use of different gases resulted in the MAG process. This is where other gases were used, for example, carbon dioxide and sometimes users refer to the process as CO2 welding. Gases such as oxygen and carbon dioxide were added and are active constituents to the inert gas to improve the welding performance. Although the MAG process is in common use today it is still referred to as MIG welding although technically this is not correct.

The process began to prove itself as an alternative to stick electrode (MMA) and TIG (GTAW) offering high productivity and deposition rates.

The process also helps reduce any weld defects from the increased stop/starts used in MMA. However, the welder must have a good knowledge of the system set up to achieve satisfactory welds.

The process also helps reduce any weld defects from the increased stop/starts used in MMA. However, the welder must have a good knowledge of the system set up to achieve satisfactory welds.

The electrode MIG gun is normally +VE and the work return is normally -VE. However, certain consumable wires sometimes require what is called reverse polarity i.e. Electrode -VE or work +VE. Typical of these types of wire are cored wires used in hard facing or high deposition and gasless applications.

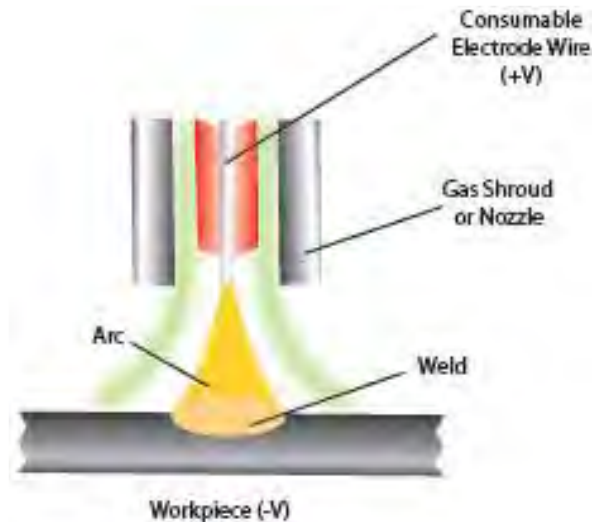

Typical welding ranges

Wire Diameter (mm)	DIP Transfer		Spray Transfer	
	Current (A)	Voltage (V)	Current (A)	Voltage (V)
0.6	30 ~ 80	15 ~ 18	n/a	n/a
0.8	45 ~ 180	16 ~ 21	150 ~ 250	25 ~ 33
1.0	70 ~ 180	17 ~ 22	230 ~ 300	26 ~ 35
1.2	60 ~ 200	17 ~ 22	250 ~ 400	27 ~ 35
1.6	100 ~ 280	18 ~ 22	250 ~ 500	30 ~ 40

GUIDE TO MIG/MAG WELDING



Before starting any welding activity ensure that you have suitable eye protection and protective clothing. Also take the necessary steps to protect any personnel within the welding area.

Notes for the welding beginner

This section is designed to give the beginner who has not yet done any welding some information to get them going. The simplest way to start is to practice by running weld beads on a piece of scrap plate. Start by using mild steel (paint free) plate of 6.0mm thick and using 0.8mm wire. Clean any grease, oil and loose scale from the plate and fix firmly to your work bench so that welding can be carried out.

Make sure that the work return clamp is secure and making good electrical contact with the mild steel plate, either directly or through the work table. For best results always clamp the work lead directly to the material being welding, otherwise a poor electrical circuit may create itself.

MIG/MAG process features and benefits

Terms used: MIG - Metal Inert Gas Welding,
MAG - Metal Active Gas Welding,
GMAW - Gas Metal Arc Welding

MIG welding was developed to help meet production demands of the war and post war economy which is an arc welding process in which a continuous solid wire electrode is fed through a MIG welding gun and into the weld pool, joining the two base materials together. A shielding gas is also sent through the MIG welding gun and protects the weld pool from contamination which also enhances the arc.

The MIG/MAG process can be used to weld a wide variety of materials and is normally used in the horizontal position but can be used in vertical or overhead with the correct selection of machine, wires and current. In addition, it can be used to weld at long distances from the power source subject to the correct cable sizing.

It is the dominant process used in maintenance and repair industries and is used extensively in structural and fabrication work.

Weld quality is also highly dependent on the skill of the operator and many welding problems can exist due to incorrect installation application and use.

Welding position

When welding, ensure you place yourself in a comfortable position for welding and your welding application before you begin to weld. This maybe sitting at a suitable height which often is the best way to weld ensuring you're relaxed and not tense. A relaxed posture will ensure the welding task becomes much easier.

Please ensure you always wear suitable PPE and use suitable fume extraction when welding.

Place the work so that the direction of welding is across, rather than to or from your body. The electrode holder lead should always be clear of any obstruction so that you can move your arm freely along as the electrode burns down. Some elders prefer to have the welding lead over their shoulder, this allows greater freedom of movement and can reduce the weight from your hand.

Always inspect your welding equipment, welding cables and electrode holder before each use to ensure it's not faulty or worn as you may be at risk of an electric shock.

GUIDE TO MIG/MAG WELDING



Before starting any welding activity ensure that you have suitable eye protection and protective clothing. Also take the necessary steps to protect any personnel within the welding area.

MIG controls

The controls for the MIG/MAG systems are as follows. Controls can be electro mechanical or electronic but the effects will be the same.

Please Note: The below describes standard MIG as Pulse and Synergic can and do function differently.

Wire feed speed

The wire speed is directly related to the current. The higher the wire speed the more wire is deposited and hence more current is required to burn off the consumable wire.

Wire speed is measured in m/min (metres per min) or sometimes in ipm (inches per minute).

The diameter of the wire also forms part of the current demand e.g. a 1.0mm wire feeding at 3m per min will require less current than a 1.2mm wire feeding at the same rate.

The wire feed is set according to the material to be welded.

If the wire feed rate is too high in comparison to the voltage then a “stubbing” effect happens where the un-melted consumable contacts the work piece creating large amounts of weld spatter.

Too little wire feed comparison to the voltage will result in a long arc being created with poor transfer and eventual burning back of the wire onto the contact tip.

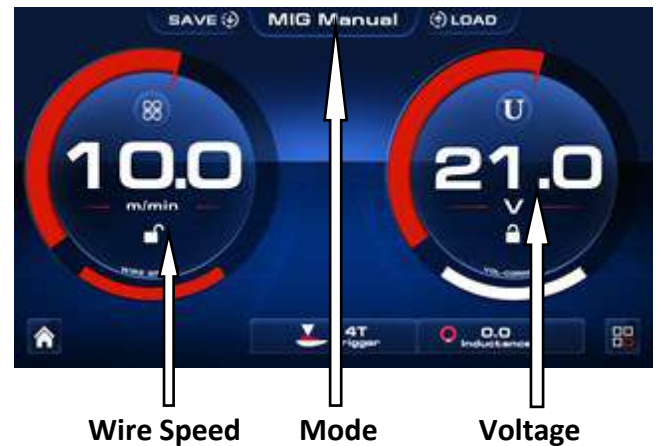

Voltage setting

The voltage polarity in MIG/MAG welding is in the majority of cases with the positive (+). This means that the majority of the heat is in the electrode wire. Certain special wires may require the polarity to be reversed i.e. electrode wire negative (-) polarity. Always consult the manufacturer's data sheet for the best operating parameters.

The voltage is often referred to as the “heat setting”. This will be altered dependent on the material type, thickness, gas type, joint type and position of the weld. Combined with the wire speed it is the main control adjusted by the welder. The voltage setting varies depending on the type and size of electrode wire being used.

Most MIG/MAG welders are CV or Constant Voltage power sources which means the voltage does not vary much during welding. Modern inverter power sources also have control circuits to monitor conditions to ensure voltage remains constant.

The voltage determines height and width of the weld bead. If the operator has no reference to settings required the best method of set up is to use scrap material of the same thickness to obtain the correct setting. If there is too much voltage the arc will be long and uncontrollable and cause the wire to fuse to the contact tip. If the voltage is too low then there will not be enough heat to melt the wire and then stubbing occurs.

To obtain a satisfactory weld a balance needs to be made between voltage and wire speed.

Characteristics of the voltage are that the higher voltage produces a flatter and wider weld bead but care must be taken to avoid undercut. The lower the voltage the weld bead becomes narrow and higher.

GUIDE TO MIG/MAG WELDING



Before starting any welding activity ensure that you have suitable eye protection and protective clothing. Also take the necessary steps to protect any personnel within the welding area.

Burn back control

In the event that the welder was to stop welding and all functions of the machine stopped simultaneously then the consumable filler wire would in all likelihood freeze in the weld pool. In order to avoid this happening the burn back feature is present on this machine.

This facility is usually an adjustable control within these Weld Star compact MIG machines and it will allow the power and gas shield to be maintained on the consumable filler wire when it has stopped feeding thereby burning clear of the weld.

The Weld Star has an in-built burn back facility which is automatically set by the weld parameters selected by the operator.

Some quick reference handy tips for the MIG/MAG welding process are:

- When welding, try to use an electrode stick out (the distance between the weld and the contact tip) of around 6-8mm
- When welding thin materials try and use smaller MIG wire diameters and for thicker materials use thicker wires
- Make sure you select the correct MIG wire type for the material to be welded
- Ensure the MIG welding gun has the correct sized contact tip and type of liner
- Always ensure you have the correct size drive rolls and torch liner for the wire size selected
- Select the correct gas to achieve the correct weld characteristics and finish
- For optimum control of the weld keep the wire at the leading edge of the weld pool
- Before commencing welding, ensure a comfortable and stable position
- Try to keep the welding torch as straight as possible when welding to ensure the best feed
- Carry out daily housekeeping on the condition of the welding torch and drive rolls
- Keep any consumables clean and dry to avoid contamination such as oxidation and damp

MIG SETUP WELDING GUIDE

Please Note: This information is intended to act as a guide only

Low carbon steel, stainless steel pulse MAG welding process reference							
Welding position	Material thickness (MM)	Wire diameter (MM)	Welding current (A)	Welding voltage (V)	Welding speed (CM/MIN)	Nozzle and workpiece spacing (MM)	Gas-flow rate (L/MIN)
Butt Joint	0.8	0.8	60-70	16-16.5	50-60	10-12	10
	1.0	0.8	75-85	17-17.5	50-60	11-13	10-15
	1.2	0.8	80-90	17-18	50-60	12-15	10-15
	1.6	1.0	80-100	19-21	40-50	12-15	10-15
	2.0	1.0	90-100	19-21	40-50	13-16	13-15
	3.2	1.2	150-170	22-25	40-50	14-17	15-17
	4.5	1.2	150-180	24-26	30-40	14-17	15-17
	6.0	1.2	270-300	28-31	60-70	17-22	18-22
	8.0	1.6	300-350	39-34	35-45	20-24	18-22
10.0	1.6	330-380	30-36	35-45	20-24	18-22	
Corner Joint	1.0	0.8	70-80	17-18	50-60	10-12	10-15
	1.2	1.0	85-90	18-19	50-60	11-13	10-15
	1.6	1.0/1.2	100-110	18-19.5	50-60	12-15	10-15
	1.6	1.0	90-130	21-25	40-50	13-16	10-15
	2.0	1.0	100-150	22-26	35-45	13-16	13-15
	3.2	1.2	160-200	23-26	40-50	13-17	13-15
	4.5	1.2	200-240	24-28	45-55	15-20	15-17
	6.0	1.2	270-300	28-31	60-70	18-22	18-22
	8.0	1.6	280-320	27-31	45-60	18-22	18-22
	10.0	1.6	330-380	30-36	40-55	20-24	18-22

MIG SETUP WELDING GUIDE

Please Note: This information is intended to act as a guide only

Welding process of aluminum alloy pulse MIG welding process reference							
Welding position	Material thickness (MM)	Wire diameter (MM)	Welding current (A)	Welding voltage (V)	Welding speed (CM/MIN)	Nozzle and workpiece spacing (MM)	Gas-flow rate (L/MIN)
Butt Joint	1.5	1.0	60-80	16-18	60-80	12-15	15-20
	2.0	1.0	70-80	17-18	40-50	15	15-20
	3.0	1.2	80-100	17-20	40-50	14-17	15-20
	4.0	1.2	90-120	18-21	40-50	14-17	15-20
	6.0	1.2	150-180	20-23	40-50	17-22	18-22
	4.0	1.2	160-210	22-25	60-90	15-20	19-20
	4.0	1.6	170-200	20-21	60-90	15-20	19-20
	6.0	1.2	200-230	24-27	40-50	17-22	20-24
	6.0	1.6	200-240	21-23	40-50	17-22	20-24
	8.0	1.6	240-270	24-27	45-55	17-22	20-24
	12.0	1.6	270-330	27-35	55-60	17-22	20-24
16.0	1.6	330-400	27-35	55-60	17-22	20-24	
Corner Joint	1.5	1.0	60-80	16-18	60-80	13-16	15-20
	2.0	1.0	100-150	22-26	35-45	13-16	15-20
	3.0	1.2	100-120	19-21	40-60	13-17	15-20
	4.0	1.2	120-150	20-22	50-70	15-20	15-20
	6.0	1.2	150-180	20-23	50-70	18-22	18-22
	4.0	1.2	180-210	21-24	35-50	18-22	16-18
	4.0	1.6	180-210	18-20	35-45	18-22	18-22
	6.0	1.2	220-250	24-25	50-60	18-22	16-24
	6.0	1.6	220-240	20-24	37-50	18-22	16-24
	8.0	1.6	250-300	25-26	60-65	18-22	16-24
	12.0	1.6	300-400	26-28	65-75	18-22	16-24

MIG WELDING PROBLEMS



Before starting any welding activity ensure that you have suitable eye protection and protective clothing. Also take the necessary steps to protect any personnel within the welding area.

MIG welding defects and prevention methods

<u>Defect</u>	<u>Possible cause</u>	<u>Action</u>
Porosity (within or outside the bead)	Poor material	Check the material is clean
	Insufficient shield gas flow	Check hoses and MIG torch for blockages
	Gas flow too low/high	Check the regulator setting or that it is not frozen due to a high flow
	Leaking hoses	Check all hoses for leaks
	Faulty gas valve	Call a service engineer
Poor or inconsistent wire feed	Working in open area with drafts	Put screens up around the weld area
	Incorrect pressure on wire drive causing burn back to contact tip or bird nesting at the feed roll	Readjust the upper feed pressure
		Increase the pressure to eliminate burn back to tip
		Decrease pressure to eliminate bird nesting
	Damage to torch liner	Replace torch liner
Welding wire contaminated or rusty	Replace wire	
No operation when the torch switch is operated	Worn welding tip	Check and replace welding tip
	Torch switch faulty	Check the torch switch continuity and replace if faulty
	Fuse blown	Check fuses and replace if necessary
Low output current	Faulty PCB inside the equipment	Call a service engineer
	Loose or defective work clamp	Tighten/replace clamp
	Loose cable plug	Re-fix plug
No operation	Power source faulty	Call a service engineer
	No operation and mains lamp not lit	Check mains fuse and replace if required
Excessive spatter	Faulty power source	Call a service engineer
	Wire feed speed too high or welding voltage too low	Reset the parameters according to the weld to be made
Excessive penetration, the weld metal is below the surface level of the material and hangs below	Heat input too high	Reduce the amperage or use a smaller electrode and lower amperage
	Poor weld technique	Use correct welding travel speed

MIG WELDING PROBLEMS



Before starting any welding activity ensure that you have suitable eye protection and protective clothing. Also take the necessary steps to protect any personnel within the welding area.

MIG welding defects and prevention methods

<u>Defect</u>	<u>Possible cause</u>	<u>Action</u>
Burning through – Holes within the material where no weld exists	Heat input too high	Use lower amperage or smaller electrode Use correct welding travel speed
Poor fusion – Failing of weld material to fuse either with the material to be welded or previous weld beads	Insufficient heat level Poor welding technique Work piece dirty	Increase the amperage or increase the electrode size and amperage Joint design must allow for full access to the root of the weld Alter welding technique to ensure penetration such as weaving, arc positioning or stringer bead technique Remove all contaminant from the material i.e. oil, grease, rust, moisture prior to welding
Irregular weld bead and shape	Incorrect voltage/wire feed settings. If its convex then the voltage is too low and if its concave then the voltage is too high. Insufficient or excessive heat input Wire is wandering Incorrect shielding gas	Adjust voltage and/or wire feed speed Adjust the wire feed speed dial or the voltage control Replace contact tip Check and change the shielding gas as required
Your weld is cracking	The weld beads too small Weld penetration narrow and deep Excessive voltage Weld/material cooling rate too fast	Try decreasing the travel speed Try reducing the wire feed speed current and voltage or increase MIG torch travel speed Decrease voltage control dial Slow the cooling rate by preheating part to be welded or cool slowly
The welding arc does not have a crisp sound that short arc exhibits when the wire feed speed or voltage are adjusted correctly	The MIG torch may have been connected to the wrong output voltage polarity on the front panel	Ensure that the MIG torch polarity lead is connected to the positive (+) welding terminal for solid wires and gas shielded flux cored wires

MIG WELDING TORCH: Weld Star MU4-1

MIG Welding Torch Air Cooled - Model: T240

Rating 250A Co2 and 220A Mixed Gases @ 60% Duty Cycle, EN60974-7, Wire Size: 0.8mm to 1.2mm

Torch Packages

T240-3 T240-4 T240-5

3 metre 4 metre 5 metre

*Euro Fitting and Bladeswitch

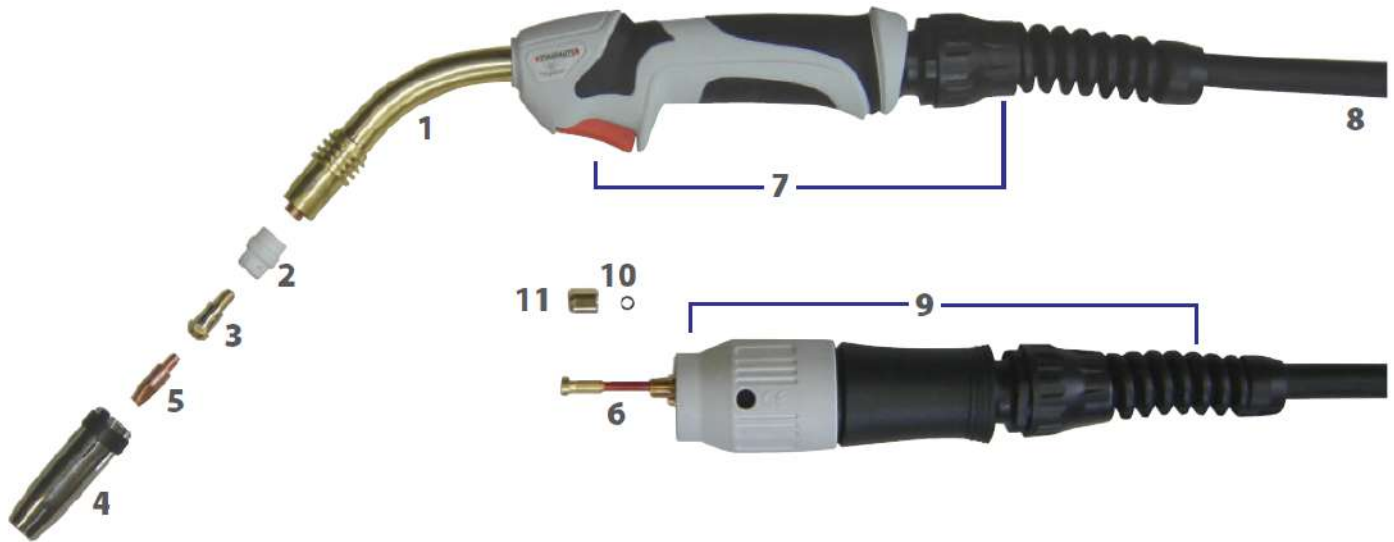

Main Consumables

Code	Description	Pack Qty
1	SP2454 Swan Neck Complete	1
2	SP2458 Diffuser Black	5
	SP2458W Diffuser White	5
3	SP2481 Tip Adaptor	5
4	SP2470 Nozzle Conical	5
	SP2471 Nozzle Cylindrical	5
	SP2472 Nozzle Tapered	5

Contact Tips (ECU M6 x 28mm)

5	SP2408 0.8mm Steel / 0.6mm Alum Wire	25
	SP2409 0.9mm Steel Wire	25
	SP2410 1.0mm Steel / 0.8mm Alum Wire	25
	SP2412 1.2mm Steel / 1.0mm Alum Wire	25

- For specifically marked ALUTips add 'A' after the part number eg: SP2410A

Contact Tips (CuCrZr M6 x 28mm)

	SP2508 0.8mm Steel / 0.6mm Alum Wire	25
	SP2509 0.9mm Steel Wire	25
	SP2510 1.0mm Steel / 0.8mm Alum Wire	25
	SP2512 1.2mm Steel / 1.0mm Alum Wire	25

Liners (Steel Plastic Coated)

Code	Description	Pack Qty
6	SP1539 0.6 - 0.9mm x 3m - P.C Blue	1
	SP1549 0.6 - 0.9mm x 4m - P.C Blue	1
	SP1559 0.6 - 0.9mm x 5m - P.C Blue	1
	SP2432 1.0 - 1.2mm x 3m - P.C Red	1
	SP2442 1.0 - 1.2mm x 4m - P.C Red	1
	SP2452 1.0 - 1.2mm x 5m - P.C Red	1

Liners (PTFE)

	SP1538T 0.6 - 0.8mm x 3m - P.C Blue	1
	SP1548T 0.6 - 0.8mm x 4m - P.C Blue	1
	SP1558T 0.6 - 0.8mm x 5m - P.C Blue	1
	SP2432T 1.0 - 1.2mm x 3m - P.C Red	1
	SP2442T 1.0 - 1.2mm x 4m - P.C Red	1
	SP2452T 1.0 - 1.2mm x 5m - P.C Red	1
	SP1511 Liner Collet	5
	SP1517 Liner 'O' Ring	10

Secondary Consumables

7	SP1625 Complete Bladeswitch Handle c/w Cable Support	1
8	SP1503 Cable Assy 3m	1
	SP1504 Cable Assy 4m	1
	SP1505 Cable Assy 5m	1
9	SP8005 Complete Euro Connection Kit c/w Support	1
10	SP1596 Gun Plug 'O' Ring	10
11	SP1597 Liner Retaining Nut	5

GUIDE TO DC TIG WELDING



Before starting any welding activity ensure that you have suitable eye protection and protective clothing. Also take the necessary steps to protect any personnel within the welding area.

DC welding

Direct current welding is when the current flows in one direction only. Compared with AC welding the current once flowing will not go to zero until welding has ended.

The Weld Star TIG Series polarity should generally be set up for Direct Current - Electrode Negative (DCEN) as this method of welding can be used for a wide range of materials.

The TIG welding torch is connected to the negative output of the machine and the work return cable to the positive output.

When the arc is established the current flows in the circuit and the heat distribution in the arc is around 33% in the negative side of the arc (the welding torch) and 67% in the positive side of the arc (the work piece). This balance gives deep arc penetration of the arc into the work piece and reduces heat in the electrode.

This reduced heat in the electrode allows more current to be carried by smaller electrodes compared to other polarity connections. This method of connection is often referred to as straight polarity and is the most common connection used in DC welding.

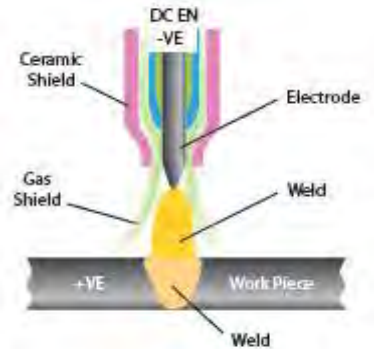

TIG welding techniques

- Before welding (especially with mild steel) you should ensure all material being welded are clean, as particulates can weaken the weld
- The torch angle is best kept at 15 - 20° (from vertical) away from the direction of travel. This assists with visibility of the weld area and allows easier access for the filler material
- The filler metal should be fed in at a low angle to help avoid touching the tungsten electrode and contaminating it
- The TIG welding arc melts the base material and the molten puddle melts the filler rod, it is important you resist the urge to melt the filler material directly into the welding arc
- For thinner sheet materials, a filler material may not be needed
- Prepare the tungsten correctly, using a diamond grinding wheel will give you the best results for a sharp point see page 39
- For welding stainless steel, be careful of applying too much heat. If the colour is dark grey and looks dirty and heavily oxidized then too much heat has been applied, this could also cause the material to warp. Reducing the amperage and increase travel speed may correct this problem, you could also consider using a smaller diameter filler material, as that will require less energy to melt

Please see the following page for the TIG DC welding amperage guide.

GUIDE TO DC TIG WELDING



Before starting any welding activity ensure that you have suitable eye protection and protective clothing. Also take the necessary steps to protect any personnel within the welding area.

Manual DC TIG Welding Amperage Guide- Mild Steel and Stainless Steel

Base Metal Thickness mm	Base Metal Thickness Inch	Tungsten Electrode Diameter	Output Polarity	Filler Wire Diameter (If Required)	Argon Gas Flow Rate (Litres/Min)	Joint Types	Amperage Range
1.6mm	1/16"	1.6mm	DC	1.6mm	5 - 8	Butt	50 - 80
1.6mm	1/16"	1.6mm	DC	1.6mm	5 - 8	Corner	50 - 80
1.6mm	1/16"	1.6mm	DC	1.6mm	5 - 8	Fillet	60 - 90
1.6mm	1/16"	1.6mm	DC	1.6mm	5 - 8	Lap	60 - 90
2.4mm	3/32"	1.6/2.4mm	DC	1.6/2.4mm	5 - 9	Butt	80 - 110
2.4mm	3/32"	1.6/2.4mm	DC	1.6/2.4mm	5 - 9	Corner	80 - 110
2.4mm	3/32"	1.6/2.4mm	DC	1.6/2.4mm	5 - 9	Fillet	90 - 120
2.4mm	3/32"	1.6/2.4mm	DC	1.6/2.4mm	5 - 9	Lap	90 - 120
3.2mm	1/8"	2.4mm	DC	2.4mm	5 - 10	Butt	80 - 120
3.2mm	1/8"	2.4mm	DC	2.4mm	5 - 10	Corner	90 - 120
3.2mm	1/8"	2.4mm	DC	2.4mm	5 - 10	Fillet	100 - 140
3.2mm	1/8"	2.4mm	DC	2.4mm	5 - 10	Lap	100 - 140
4.8mm	3/16"	2.4mm	DC	2.4mm	6 - 11	Butt	120 - 200
4.8mm	3/16"	2.4mm	DC	2.4mm	6 - 11	Corner	150 - 200
4.8mm	3/16"	2.4mm	DC	2.4mm	6 - 11	Fillet	170 - 220
4.8mm	3/16"	2.4mm	DC	2.4mm	6 - 11	Lap	150 - 200
6.4mm	1/4"	2.4mm	DC	3.2mm	7 - 12	Butt	225 - 300
6.4mm	1/4"	2.4mm	DC	3.2mm	7 - 12	Corner	250 - 300
6.4mm	1/4"	2.4mm	DC	3.2mm	7 - 12	Fillet	250 - 320
6.4mm	1/4"	2.4mm	DC	3.2mm	7 - 12	Lap	250 - 320
9.5mm	3/8"	3.2mm	DC	3.2mm	7 - 12	Butt	250 - 360
9.5mm	3/8"	3.2mm	DC	3.2mm	7 - 12	Corner	260 - 360
9.5mm	3/8"	3.2mm	DC	3.2mm	7 - 12	Fillet	270 - 380
9.5mm	3/8"	3.2mm	DC	3.2mm	7 - 12	Lap	230 - 380
12.7mm	1/2"	3.2/4mm	DC	3.2mm	8 - 13	Butt	300 - 400
12.7mm	1/2"	3.2/4mm	DC	3.2mm	8 - 13	Corner	320 - 420
12.7mm	1/2"	3.2/4mm	DC	3.2mm	8 - 13	Fillet	320—420
12.7mm	1/2"	3.2/4mm	DC	3.2mm	8 - 13	Lap	320 - 420

Please Note:

- All above guide settings are approximate and will vary depending on application, prep, passes and type of welding equipment used.
- The welds would need to be tested to ensure they comply to your welding specifications.

GUIDE TO TIG WELDING



Before starting any welding activity ensure that you have suitable eye protection and protective clothing. Also take the necessary steps to protect any personnel within the welding area.

TIG torch body and components

The torch body holds the various welding consumables in place as shown and is covered by a either a rigid phenolic or rubberised covering.

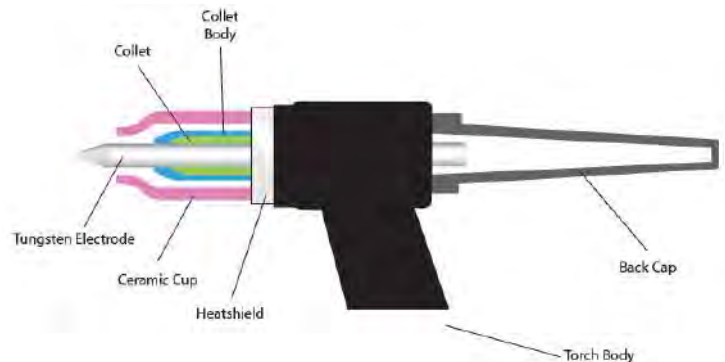

Collet body



The collet body screws into the torch body. It is replaceable and is changed to accommodate the different size tungsten's and their respective collets.

Collets



The welding electrode (tungsten) is held in the torch by the collet. The collet is usually made of copper or a copper alloy. The collet's grip on the electrode is secured when the torch back cap is tightened in place. Good electrical contact between the collet and tungsten electrode is essential for good welding current transfer.

Gas lens body



A gas lens is a device that can be used in place of the normal collet body. It screws into the torch body and is used to reduce turbulence in the flow of shield gas and produce a stiff column of undisturbed flow of shielding gas. A gas lens will allow the welder to move the nozzle further away from the joint allowing increased visibility of the arc.

A much larger diameter nozzle can be used which will produce a large blanket of shielding gas. This can be very useful in welding material like titanium. The gas lens will also enable the welder to reach joints with limited access such as inside corners.

Ceramic cups



Gas cups are made of various types of heat resistant materials in different shapes, diameters and lengths. The cups are either screwed onto the collet body or gas lens body or in some cases pushed in place. Cups can be made of ceramic, metal, metal-jacketed ceramic, glass or other materials. The ceramic type is quite easily broken so take care when putting the torch down.

Gas cups must be large enough to provide adequate shielding gas coverage to the weld pool and surrounding area. A cup of a given size will allow only a given amount of gas to flow before the gas flow becomes disturbed due to the speed of flow. Should this condition exist the size of cup should be increased to allow the flow speed to reduce and once again establish an effective regular shield.

Back cap

The back cap screws into the rear on the torch head and applies pressure to the back end of the collet which in turn forces up against the collet body, the resulting pressure holds the tungsten in place to ensure it does not move during the welding process.

Back caps are made from a rigid phenolic material and generally come in 3 sizes, short, medium and long.

GUIDE TO TIG WELDING



Before starting any welding activity ensure that you have suitable eye protection and protective clothing. Also take the necessary steps to protect any personnel within the welding area.

TIG welding electrodes

TIG welding electrodes are a 'non consumable' as it is not melted into the weld pool and great care should be taken not to let the electrode contact the welding pool to avoid weld contamination. This would be referred to as tungsten inclusion and may result in weld failure.

Electrodes will often contain small quantities of metallic oxides which can offer the following benefits:

- Assist in arc starting
- Improve current carrying capacity of the electrode
- Reduce the risk of weld contamination
- Increase electrode life
- Increase arc stability

Oxides used are primarily zirconium, thorium, lanthanum or cerium. These are added usually 1% - 4%.



Tungsten Electrode Colour Chart - DC

Welding Mode	Tungsten Type	Colour
DC or AC/DC	Ceriated 2%	Grey
DC or AC/DC	Lanthanated 1%	Black
DC or AC/DC	Lanthanated 1.5%	Gold
DC or AC/DC	Lanthanated 2%	Blue
DC	Thoriated 1%	Yellow
DC	Thoriated 2%	Red

Tungsten Electrode Current Ranges

Tungsten Electrode Size	DC Current Amp
1.0mm	30 - 60
1.6mm	60 - 115
2.4mm	100 - 165
3.2mm	135 - 200
4.0mm	190 - 280
4.8mm	250 - 340

Tungsten electrode preparation - DC

When welding at low current the electrode can be ground to a point. At higher current a small flat on the end of the electrode is preferable as this helps with arc stability.

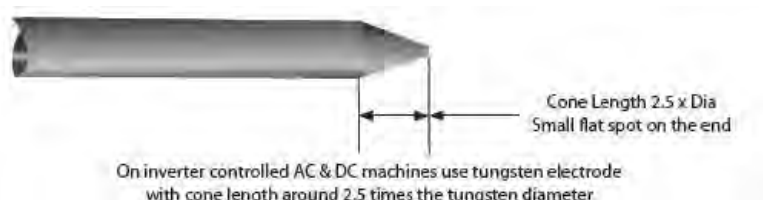

Electrode grinding

It is important when grinding the electrode to take all necessary precautions such as wearing eye protection and ensuring adequate protection against breathing in any grinding dust.

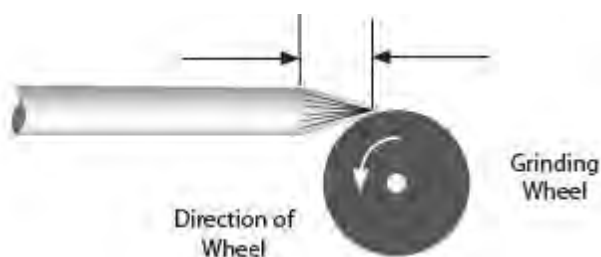

Tungsten electrodes should always be ground lengthwise (as shown) and not in a radial operation. Electrodes ground in a radial operation tend to contribute to arc wander due to the arc transfer from the grinding pattern. Always use a grinder solely for grinding electrodes to avoid contamination.

GUIDE TO TIG WELDING



Before starting any welding activity ensure that you have suitable eye protection and protective clothing. Also take the necessary steps to protect any personnel within the welding area.

TIG welding consumables

The consumables of the TIG welding process are filler wires and shield gas.

Filler wires

Filler wires come in many different material types and usually as cut lengths, unless some automated feeding is required where it will be in reel form. Filler wire is generally fed in by hand. Always consult the manufacturer's data and welding requirements.

Filler Wire Diameter	DC Current Range (Amps)
1.0mm	20-90
2.4mm	65-115
3.2mm	100-165
4.8mm	200-350

Filler Wire Selection Guide

Gases

Shielding gas is required when welding to keep the weld pool free of oxygen. Whether you are welding mild steel or stainless steel the most commonly used shielding gas used in TIG welding is argon, for more specialised applications an argon helium mix or pure helium maybe used.

TIG welding arc starting - Lift TIG (lift arc)

Not to be confused with scratch start, this arc starting method allows the tungsten to be in direct contact with the work piece first but with minimal current so as not to leave a tungsten deposit when the tungsten is lifted and an arc is established.

With lift TIG start the open circuit voltage (OCV) of the welder folds back to a very low voltage output when the unit senses it has made continuity with the work piece. Once the torch is lifted the unit increases output as the tungsten leaves the surface. This creates little contamination and preserves the point on the tungsten although this is still not a 100% clean process.

The tungsten can still get contaminated but lift TIG is still a much better option than scratch starting for mild and stainless steel although these methods of arc starting are not a good option when welding aluminium.

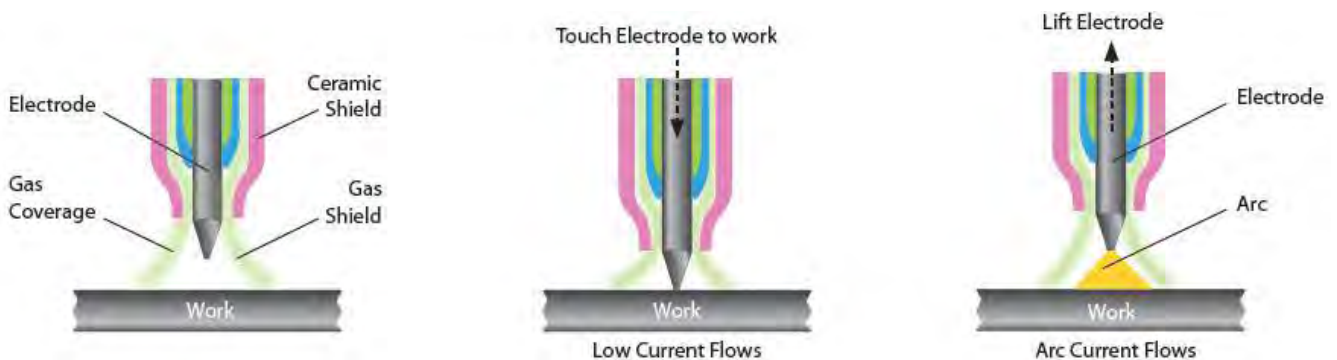

GUIDE TO TIG WELDING



Before starting any welding activity ensure that you have suitable eye protection and protective clothing. Also take the necessary steps to protect any personnel within the welding area.

Arc starting - lift TIG (lift arc)

Not to be confused with scratch start, this arc starting method allows the tungsten to be in direct contact with the work piece first but with minimal current so as not to leave a tungsten deposit when the tungsten is lifted and an arc is established.

With lift TIG start the open circuit voltage (OCV) of the welder folds back to a very low voltage output when the unit senses the tungsten has made continuity with the work piece. Once the torch is lifted the unit increases output as the tungsten leaves the surface. This creates little contamination and preserves the point on the tungsten although this is still not a 100% clean process. The tungsten still can get contaminated but lift TIG is a much better option than scratch starting for mild and stainless steel although these methods of arc starting are not a good option when welding aluminium.

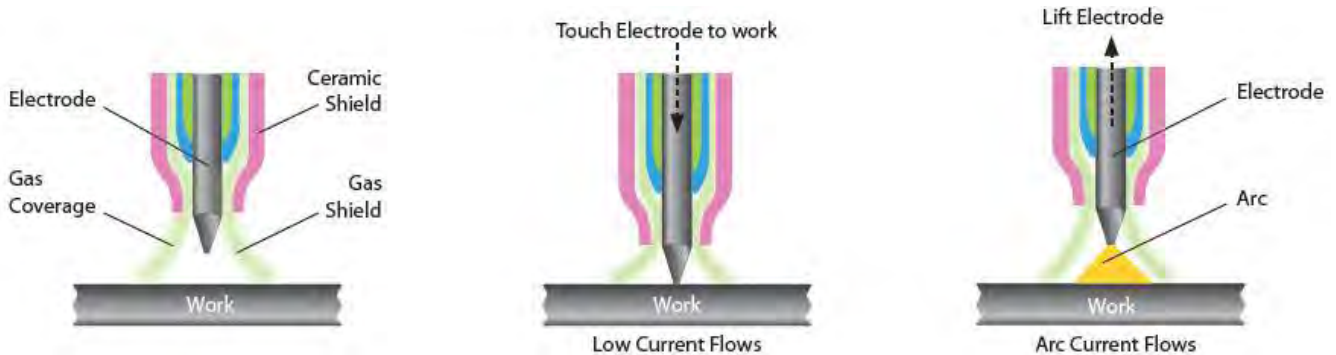

Arc starting - HF start

Non contact High Frequency (HF) start method is a high voltage and low amperage generated using a spark gap assembly and is the most popular and generally considered best TIG arc starting method. The High Frequency (HF) start generates a high frequency arc that ionizes the gas bridging the gap between the tungsten point and the work piece. This touchless method creates almost no contamination unless the tungsten has been over sharpened or the start amperage is too high. It is an excellent choice for all material being welded especially aluminium although, unless you need to weld aluminium, you don't have to use HF start steel/stainless.

The HF frequency varies with the spark gap and can be around 16000 Hz to 100000 Hz depending on spark gap width so consideration should be given with this method as it can cause electrical interference to nearby electrical equipment such as computers, CNC controls and phone systems.

If the spark gap is widened, the HF can become erratic.



GUIDE TO AC TIG WELDING



Before starting any welding activity ensure that you have suitable eye protection and protective clothing. Also take the necessary steps to protect any personnel within the welding area.

AC TIG welding

Alternating current, AC welding, is when the current once flowing will not go to zero until welding has ended, compared with DC welding when the current flows in one direction only.

The Jasic TIG series polarity should generally be set up like Direct Current - Electrode Negative (DCEN) as this method of welding can be used for a wide range of materials.

The TIG welding torch is connected to the negative output of the machine and the work return cable to the positive output.

When the arc is established the current supplied by the machine operates with either positive and negative elements of half cycles. This means current flows one way and then the other at different times so the term alternating current is used. The combination of one positive element and one negative element is termed one cycle

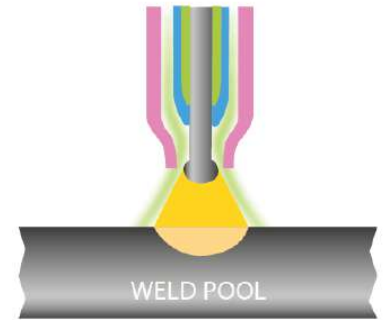

The number of times a cycle is completed within one second is referred to as the frequency. In the UK the frequency of alternating current supplied by the mains network is 50 cycles per second and is denoted as 50 Hertz (Hz).

This would mean that the current changes 100 times each second. The number of cycles per second (frequency) in a standard machine is dictated by the mains frequency which in the UK is 50Hz.

It is worth noting that as frequency increases magnetic effects increase and items such as transformers become increasingly more efficient. Also increasing the frequency of the welding current stiffens the arc, improves arc stability and leads to a more controllable welding condition.

However, this is theoretical as when welding in the TIG mode there are other influences on the arc. The AC sine wave can be affected by the oxide coating of some materials which acts as a rectifier restricting the electron flow. This is known as arc rectification and its effect causes the positive half cycle to be clipped off or distorted. The effect for the weld zone is erratic arc conditions, lack of cleaning action and possible tungsten damage.

See following page for the TIG AC welding amperage guide

GUIDE TO AC TIG WELDING



Before starting any welding activity ensure that you have suitable eye protection and protective clothing. Also take the necessary steps to protect any personnel within the welding area.

Manual AC TIG Welding Amperage Guide - Aluminium Material

Base Metal Thickness mm	Base Metal Thickness Inch	Tungsten Electrode Diameter	Output Polarity	Filler Wire Diameter (If Required)	Argon Gas Flow Rate (Litres/Min)	Joint Types	Amperage Range Guide
1.6mm	1/16"	1.6mm	AC	1.6mm	6 - 9	Butt	65—75
1.6mm	1/16"	1.6mm	AC	1.6mm	6 - 9	Corner	55—65
1.6mm	1/16"	1.6mm	AC	1.6mm	6 - 9	Fillet	55—75
1.6mm	1/16"	1.6mm	AC	1.6mm	6 - 9	Lap	60—70
2.4mm	3/32"	1.6/2.4mm	AC	1.6/2.4mm	8 - 10	Butt	80—110
2.4mm	3/32"	1.6/2.4mm	AC	1.6/2.4mm	8 - 10	Corner	80—110
2.4mm	3/32"	1.6/2.4mm	AC	1.6/2.4mm	8 - 10	Fillet	90—130
2.4mm	3/32"	1.6/2.4mm	AC	1.6/2.4mm	8 - 10	Lap	95—130
3.2mm	1/8"	2.4mm	AC	2.4mm	8 - 11	Butt	115—135
3.2mm	1/8"	2.4mm	AC	2.4mm	8 - 11	Corner	90—120
3.2mm	1/8"	2.4mm	AC	2.4mm	8 - 11	Fillet	100—140
3.2mm	1/8"	2.4mm	AC	2.4mm	8 - 11	Lap	105—130
4.8mm	3/16"	2.4mm	AC	2.4mm	9 - 12	Butt	125—150
4.8mm	3/16"	2.4mm	AC	2.4mm	9 - 12	Corner	130—160
4.8mm	3/16"	2.4mm	AC	2.4mm	9 - 12	Fillet	150—180
4.8mm	3/16"	2.4mm	AC	2.4mm	9 - 12	Lap	130—170
6.4mm	1/4"	2.4mm	AC	2.4mm	11 - 14	Butt	190—220
6.4mm	1/4"	2.4mm	AC	2.4mm	11 - 14	Corner	140—170
6.4mm	1/4"	2.4mm	AC	2.4mm	11 - 14	Fillet	170—190
6.4mm	1/4"	2.4mm	AC	2.4mm	11 - 14	Lap	160—180
9.5mm	3/8"	3.2mm	AC	3.2mm	12 - 15	Butt	110—260
9.5mm	3/8"	3.2mm	AC	3.2mm	12 - 15	Corner	130—260
9.5mm	3/8"	3.2mm	AC	3.2mm	12 - 15	Fillet	240—270
9.5mm	3/8"	3.2mm	AC	3.2mm	12 - 15	Lap	230—250
12.7mm	1/2"	3.2/4mm	AC	3.2mm	13 - 16	Butt	120—290
12.7mm	1/2"	3.2/4mm	AC	3.2mm	13 - 16	Corner	145—300
12.7mm	1/2"	3.2/4mm	AC	3.2mm	13 - 16	Fillet	320—350
12.7mm	1/2"	3.2/4mm	AC	3.2mm	13 - 16	Lap	280—320

Please Note:

- All above guide settings are approximate and will vary depending on application, prep, passes and type of welding equipment used.
- The welds would need to be tested to ensure they comply to your welding specifications.

GUIDE TO AC TIG WELDING



Before starting any welding activity ensure that you have suitable eye protection and protective clothing. Also take the necessary steps to protect any personnel within the welding area.

AC TIG welding square wave

With the electronic development of inverter power sources, the square wave machine was developed. Due to these electronic controls the cross over from positive to negative and vice versa can be made almost in an instant which leads to more effective current in each half cycle due to a longer period at maximum. The effective use of the magnetic field energy stored creates waveforms which are very near square.

The WS-MU4-1 offers a square wave signal that allows us control of the positive (cleaning) and negative (penetration) half cycles.

The balance condition with equal positive and negative half cycles will give a stable weld condition. The problems that can be encountered are that once cleaning has occurred in less than the positive half cycle time then some of the positive half cycle is not productive and can also increase potential damage to the electrode due to overheating. However, this can be eliminated by the use of balance control which allows the time of the positive half cycle to be varied within the cycle time.

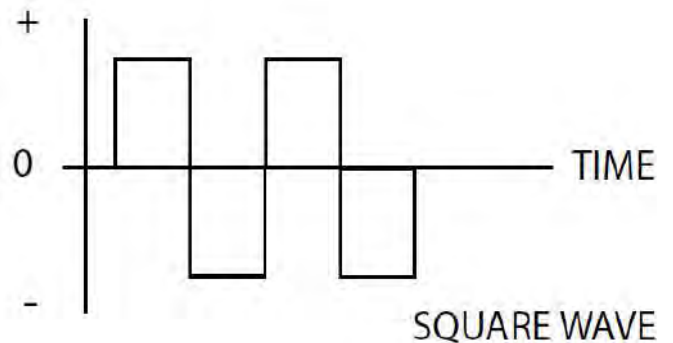

- I0 - Initial current
- I1 - Welding current
- I2 - Final current
- tu - Upslope time
- td - Downslope time
- tp - AC period
- tc - Cathode current time

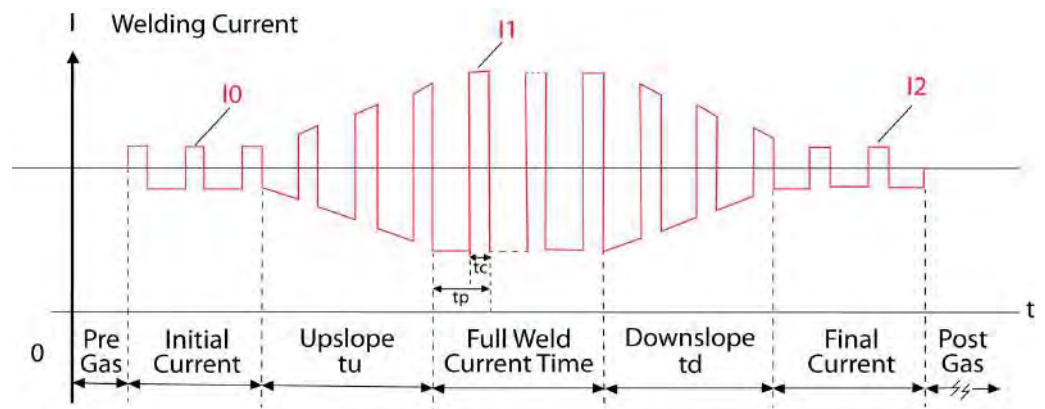

In AC square wave TIG welding, the pre flow time and post flow time are the same as in DC TIG welding. Others parameters are described below:

Initial current (I0), welding current (I1) and pilot arc current (I2).

The preset value of the three parameters is approximately the absolute average of the practical welding current and can be adjusted according to users technical requirements.

Pulse frequency ($1/tp$): It can be adjusted according to users technical requirements.

Cleaning strength ($100\% * Tc/tp$): Generally, in AC welding when taking the electrode as the anode, the current is called the cathode current. Its main function is to break up the oxidized layer of the work piece and the cleaning strength is the percentage cathode current holding in the AC period.

This parameter is $-20 \sim +20\%$ commonly. When the value is smaller the arc is concentrated and the molten pool is narrow and deep although when the value is larger, the arc is spread, the molten pool is wide and shallow.

GUIDE TO AC TIG WELDING



Before starting any welding activity ensure that you have suitable eye protection and protective clothing. Also take the necessary steps to protect any personnel within the welding area.

AC pulsed TIG welding

Tc - Cathode current time

Tp - AC period

Tp - Pulsed peak current time

T - Pulse period

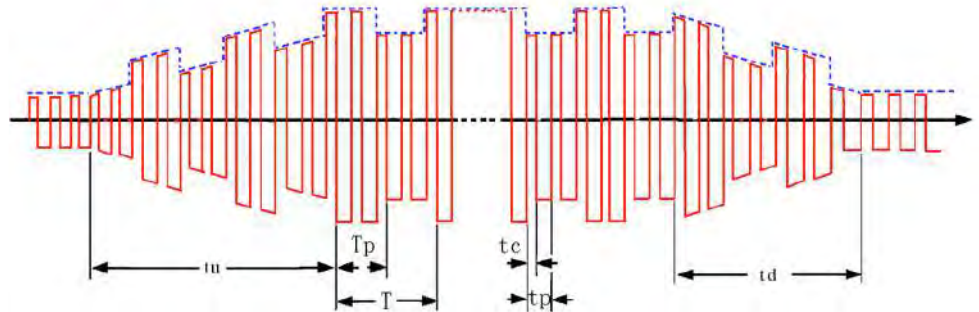

AC pulsed TIG welding is almost the same as AC square wave TIG welding and what makes them different is that in AC pulsed TIG welding the welding current varies with the pulse peak current and base current. For the AC square wave parameter selecting and setting, please refer to the corresponding contents in AC square wave TIG welding. For the pulse frequency and pulse duration ratio users may refer to the corresponding contents in DC pulsed TIG welding.

The pulse frequency ($1/T$) can be adjusted between 0.5Hz and 999Hz. The pulse duration ratio (T_p/T) can be adjusted between 10% and 90%.

AC frequency

The normal mains frequency of equipment is 50Hz. However, the WS-MU4-1 AC/DC has an output adjustment range of between 50 ~ 250Hz (see machine display to confirm).

With TIG welding power supplies that have an adjustable AC frequency, lowering the AC frequency would provide a softer, less forceful wide arc which offers a wider bead with shallow penetration.

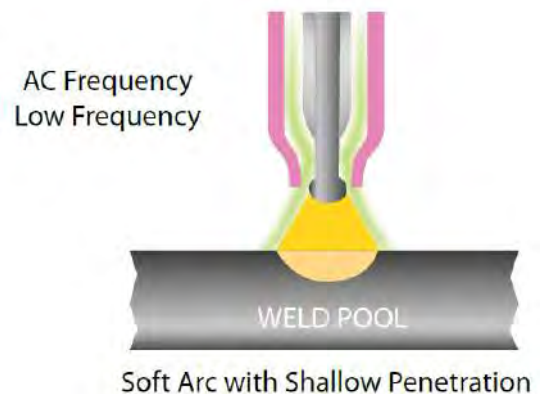

Increasing the AC frequency has the effect of concentrating the arc making it easily directional with narrower bead with deeper penetration.

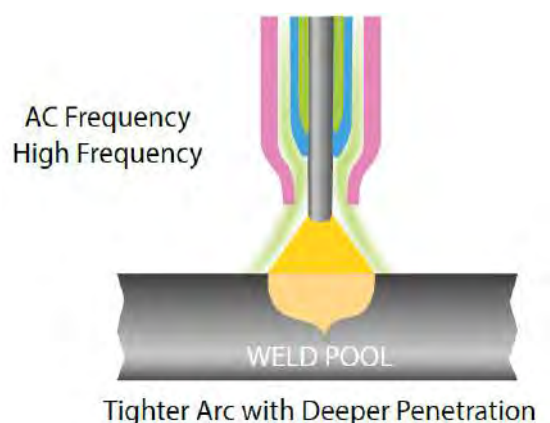

GUIDE TO AC TIG WELDING



Before starting any welding activity ensure that you have suitable eye protection and protective clothing. Also take the necessary steps to protect any personnel within the welding area.

AC Wave balance or cleaning control

When welding materials with a refractory oxide surface such as aluminium this oxide needs to be removed to allow welding of the base material. In the AC mode the oxide is removed during the positive half of the AC wave. This control allows the user to set the amount of time between positive and negative which is represented by moving A or B in the image right.

The higher the setting the more aggressive the cleaning action but more time in the positive cycle drives more energy into the tungsten so care should be taken to avoid overheating the tungsten. AC balance zero is normally 50% positive and 50% negative.

Please Note:

For the WS-MU4-1 the factor set balanced 'zero' point is represented as zero on the digital display and the range of balance varies between -5 ~ +5 (see machine display to confirm).

With the correct setting of the frequency and balance controls it is possible to use a smaller size tungsten.

Maximum penetration

This can be achieved by placing the control to a position which will enable more time to be spent in the negative half cycle with respect to the positive half cycle. This will allow for higher current to be used with smaller electrodes as more of the heat is in the positive (work). The increase in heat also results in deeper penetration when welding at the same travel speed as the balanced condition, a reduced heat affected zone and less distortion due to the narrower arc.

Please Note:

To obtain more penetration for the WS-MU4-1, the AC balance adjustment range is represented between -5 ~ +5 (see machine display to confirm).

Maximum cleaning

This can be achieved by placing the control to a position which will enable more time to be spent in the positive half cycle with respect to the negative half cycle. This will allow for very active cleaning current to be used. It should be noted that there is an optimum cleaning time after which more cleaning will not occur and the potential of damage to the electrode is greater. The effect on the arc is to provide a wider clean weld pool with shallow penetration.

Please Note:

To obtain more cleaning for the WS-MU4-1, the AC balance adjustment range is represented between -5 ~ +5 (see machine display to confirm).

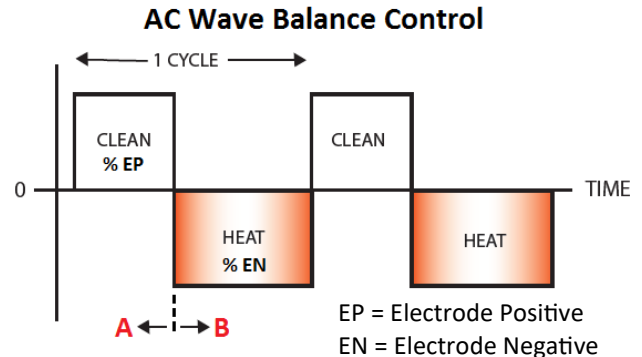

TIG WELDING TORCH: Weld Star MU4-1

TIG Welding Torch Air Cooled - Model TIG-103

Rating 200A DC, 150A AC @ 60% Duty Cycle EN60974-7 • 0.5mm to 4.0mm Electrodes

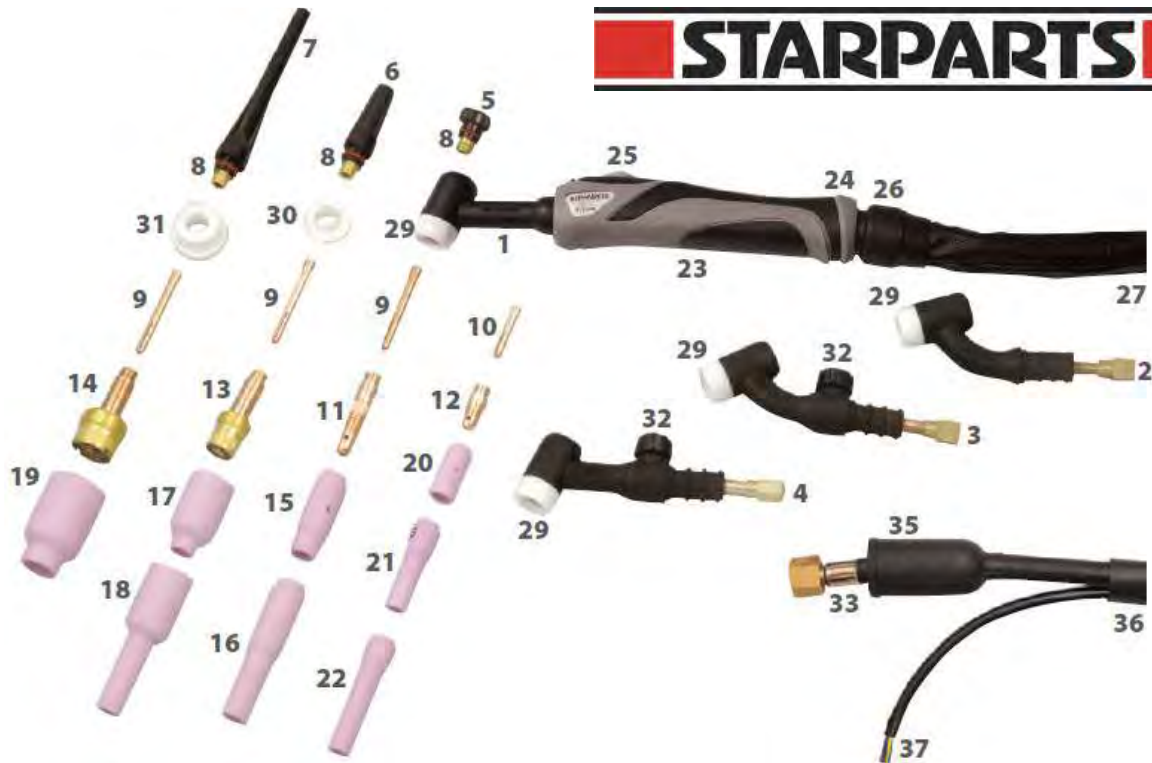

Main Consumables

No	Code	Description
1	WP17	Rigid Torch Body
2	WP17F	Flexible Torch Body
3	WP17FV	Flexible Torch Body c/w Valve
4	WP17V	Torch Body c/w Argon Valve
5	57Y04	Short Back Cap
6	300M	Medium Back Cap
7	57Y02	Long Back Cap
8	98W18	Back Cap 'O' Ring

Collets

9	10N21	Standard .020" (0.5mm)
	10N22	Standard .040" (1.0mm)
	10N23	Standard 1/16" (1.6mm)
	10N26	Standard 5/64" (2.0mm)
	10N24	Standard 3/32" (2.4mm)
	10N25	Standard 1/8" (3.2mm)
10	10N21S	Stubby .020" (0.5mm)
	10N22S	Stubby .040" (1.0mm)
	10N23S	Stubby 1/16" (1.6mm)
	10N24S	Stubby 3/32" (2.4mm)
	10N25S	Stubby 1/8" (3.2mm)

Collet Bodies

11	10N29	Standard .020" (0.5mm)
	10N30	Standard .040" (1.0mm)
	10N31	Standard 1/16" (1.6mm)
	10N31M	Standard 5/64" (2.0mm)
	10N32	Standard 3/32" (2.4mm)
	10N28	Standard 1/8" (3.2mm)
12	17CB20	Stubby .020"- 1/8" (0.5 - 3.2mm)

Gas Lens Bodies

13	45V29	Standard .020" (0.5mm)
	45V24	Standard .040" (1.0mm)
	45V25	Standard 1/16" (1.6mm)
	45V25M	Standard 5/64" (2.0mm)
	45V26	Standard 3/32" (2.4mm)
	45V27	Standard 1/8" (3.2mm)

Gas Lens Bodies

14	45V0204	Large Dia .020"-.040" (0.5 - 1.0mm)
	45V116	Large Dia 1/16" (1.6mm)
	45V64	Large Dia 3/32" (2.4mm)
	995795	Large Dia 1/8" (3.2mm)

Ceramic Cups

15	10N50	Standard Cup 1/4" Bore
	10N49	Standard Cup 5/16" Bore
	10N48	Standard Cup 3/8" Bore
	10N47	Standard Cup 7/16" Bore
	10N46	Standard Cup 1/2" Bore
	10N45	Standard Cup 5/8" Bore
	10N44	Standard Cup 3/4" Bore
16	10N50L	Long Cup 1/4" Bore
	10N49L	Long Cup 5/16" Bore
	10N48L	Long Cup 3/8" Bore
	10N47L	Long Cup 7/16" Bore

Gas Lens Cups

17	54N18	Standard Cup 1/4" Bore
	54N17	Standard Cup 5/16" Bore
	54N16	Standard Cup 3/8" Bore
	54N15	Standard Cup 7/16" Bore
	54N14	Standard Cup 1/2" Bore
	54N19	Standard Cup 11/16" Bore
18	54N17L	Long Cup 5/16" Bore
	54N16L	Long Cup 3/8" Bore
	54N15L	Long Cup 7/16" Bore
	54N14L	Long Cup 1/2" Bore
19	57N75	Large Dia Cup 3/8" Bore
	57N74	Large Dia Cup 1/2" Bore
	53N88	Large Dia Cup 5/8" Bore
	53N87	Large Dia Cup 3/4" Bore

Ceramic Cups for use with item 12

20	13N08	Standard Cup 1/4" Bore
	13N09	Standard Cup 5/16" Bore
	13N10	Standard Cup 3/8" Bore
	13N11	Standard Cup 7/16" Bore
	13N12	Standard Cup 1/2" Bore
	13N13	Standard Cup 5/8" Bore
21	796F70	Long Cup 3/16" Bore
	796F71	Long Cup 1/4" Bore
	796F72	Long Cup 5/16" Bore
	796F73	Long Cup 3/8" Bore
22	796F74	X - Long Cup 3/16" Bore
	796F75	X - Long Cup 1/4" Bore
	796F76	X - Long Cup 5/16" Bore
	796F77	X - Long Cup 3/8" Bore

Secondary Consumables

23	SP9110	LH & RH Handle Shell
24	SP9111	Handle Screw
25	SP9120	Single Button Switch
	SP9121	2 Button Switch
	SP9122	5K Potentiometer Switch
	SP9123	10K Potentiometer Switch
	SP9128	47K Potentiometer Switch
	SP9129	4 Button Switch
26	SP9113	Handle Ball Joint
27	SP9116	Leather Cover 800mm
28	SP9118	Cable Cover Joint (not illustrated)
29	18CG	Standard Heat Shield
30	54N01	Gas Lens Heat Shield
31	54N63	Large Gas Lens Insulator
32	VS-2	Valve Stem WP17V & WP17FV
33	57Y01	Mono Power Cable 12.5ft - 3/8"
	57Y03	Mono Power Cable 25ft - 3/8" Bsp
34	57Y01-2D	2 Piece Power Cable Assy 12.5ft
	57Y03-2D	2 Piece Power Cable Assy 25ft
35	0315071	Insulation Boot
36	SP9002	Neoprene Protective Cover 1m
37	SP9126	4m Switch Cable
	SP9127	8m Switch Cable

H12PP	12 Pin Control Plug
JSG-PLUG-9PIN	9 Pin Control Plug

PLEASE NOTE:

Check torch supplied with your package to ensure it matches the above details

TIG WELDING PROBLEMS



Before starting any welding activity ensure that you have suitable eye protection and protective clothing. Also take the necessary steps to protect any personnel within the welding area.

TIG welding defects and prevention methods

<u>Defect</u>	<u>Possible cause</u>	<u>Action</u>
Excessive tungsten use	Set up for DCEP	Change to DCEN
	Insufficient shield gas flow	Check for gas restriction and correct flow rates. Check for drafts in the weld area.
	Electrode size too small	Select correct size
	Electrode contamination during cooling time	Extend post flow gas time
Porosity/weld contamination	Loose torch or hose fitting	Check and tighten all fittings
	Inadequate shield gas flow	Adjust flow rate - normally 8-12L/m
	Incorrect shield gas	Use correct shield gas
	Gas hose damaged	Check and repair any damaged hoses
	Base material contaminated	Clean material properly
	Incorrect filler material	Check correct filler wire for grade of use
No operation when torch switch is operated	Torch switch or cable faulty	Check the torch switch continuity and repair or replace as required
	ON/OFF switch turned off	Check position of ON/OFF switch
	Mains fuses blown	Check fuses and replace as required
	Fault inside the machine	Call for a repair technician
Low output current	Loose or defective work clamp	Tighten/replace clamp
	Loose cable plug	Check and tighten all plugs
	Power source faulty	Call a repair technician
Will not strike an arc	Weld/power cable open circuit	Check all cables and connections for continuity, especially the torch cables
	No shield gas flowing	Check cylinder contents, regulator and valves, also check the power source
Unstable arc when welding in DC	Tungsten contaminated	Break off contaminated end and regrind the tungsten
	Arc length incorrect	Arc length should be between 3-6mm
	Material contaminated	Clean all base and filler material
	Electrode connected to the wrong polarity	Reconnect to correct polarity
Arc is difficult to start	Incorrect tungsten type	Check and fit correct tungsten
	Incorrect shield gas	Use argon shield gas

TIG WELDING PROBLEMS



Before starting any welding activity ensure that you have suitable eye protection and protective clothing. Also take the necessary steps to protect any personnel within the welding area.

TIG welding defects and prevention methods

<u>Defect</u>	<u>Possible cause</u>	<u>Action</u>
Excessive bead build up, poor penetration or poor fusion at the edges of the weld	Weld current too low	Increase the welding amperage Poor material prep
Weld bead flat and too wide or undercut at the weld edge or burning through	Weld current too high	Decrease the welding amperage
Weld bead too small or insufficient penetration	Welding travel speed too fast	Reduce your welding travel speed
Weld bead too wide or excessive bead build up	Welding travel speed too slow	Increase your welding travel speed
Uneven leg length in fillet joint	Wrong placement of filler rod	Re-position filler rod
Tungsten melts or oxidises when welding arc is made	TIG torch lead connected to + Little or no gas flow to weld pool Gas cylinder or hoses contain impurities The tungsten is too small for the weld current TIG/MMA selector set to MMA	Connect to - polarity Check gas apparatus as well as torch and hoses for breaks or restrictions Change gas cylinder and blow out torch and gas hoses Increase the size of the tungsten Ensure you have the power source set to TIG function

GUIDE TO MMA WELDING



Before starting any welding activity ensure that you have suitable eye protection and protective clothing. Also take the necessary steps to protect any personnel within the welding area.

Notes for the welding beginner

This section is designed to give the beginner who has not yet done any welding some information to get them going. The simplest way to start is to practice by running weld beads on a piece of scrap plate. Start by using mild steel (paint free) plate of 6.0mm thick and using 3.2mm electrodes.

Clean any grease, oil and loose scale from the plate and fix firmly to your work bench so that welding can be carried out. Make sure that the work return clamp is secure and making good electrical contact with the mild steel plate, either directly or through the work table. For best results always clamp the work lead directly to the material being welded, otherwise a poor electrical circuit may create itself.

Welding position

When welding, ensure you place yourself in a comfortable position for welding and your welding application before you begin to weld. This maybe sitting at a suitable height which often is the best way to weld ensuring you're relaxed and not tense. A relaxed posture will ensure the welding task becomes much easier.

Please ensure you always wear suitable PPE and use suitable fume extraction when welding.

Place the work so that the direction of welding is across, rather than to or from your body.

The electrode holder lead should always be clear of any obstruction so that you can move your arm freely along as the electrode burns down. Some elders prefer to have the welding lead over their shoulder, this allows greater freedom of movement and can reduce the weight from your hand.

Always inspect your welding equipment, welding cables and electrode holder before each use to ensure it's not faulty or worn as you may be at risk of an electric shock.

MMA process features and benefits

The versatility of the process and the skill level required to learn, basic simplicity of the equipment make the MMA process one of the most common used throughout the world.

The MMA process can be used to weld a wide variety of materials and is normally used in the horizontal position but can be used in vertical or overhead with the correct selection of electrode and current. In addition, it can be used to weld at long distances from the power source subject to the correct cable sizing. The self shielding effect of the electrode coating makes the process suitable for welding in external environments. It is the dominant process used in maintenance and repair industries and is used extensively in structural and fabrication work.

The process is well able to cope with less than ideal material conditions such as dirty or rusty material. Disadvantages of the process are the short welds, slag removal and stop/starts which lead to poor weld efficiency which is in the region of 25%. The weld quality is also highly dependent on the skill of the operator and many welding problems can exist.

GUIDE TO MMA WELDING



Before starting any welding activity ensure that you have suitable eye protection and protective clothing. Also take the necessary steps to protect any personnel within the welding area.

MMA process tips and guides

Typical welder set up

1. Electrode holder
2. Work return clamp
3. Work piece
4. Weld material covered by electrode flux or slag
5. Electrode
6. Distance from work to electrode (arc Length)

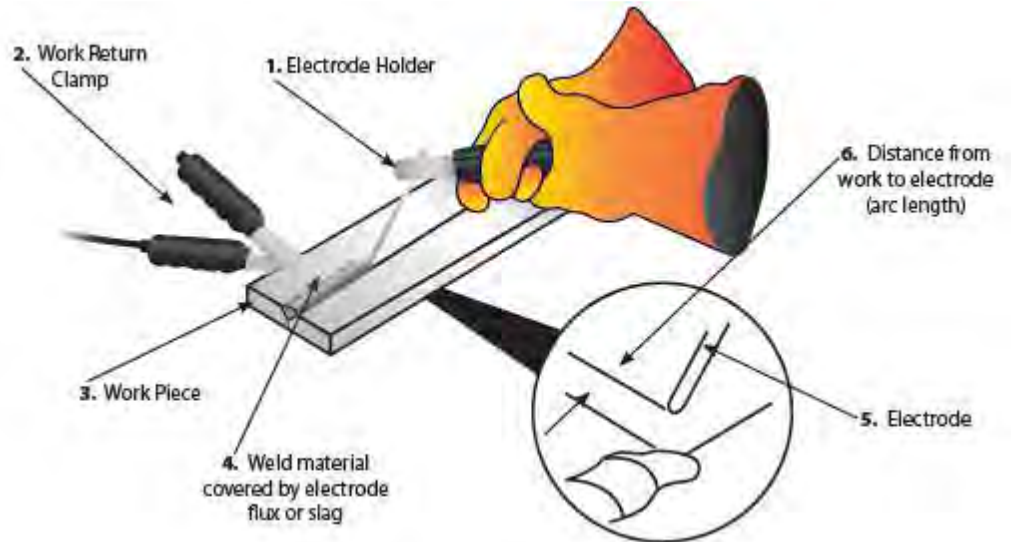

Welding current will flow in the circuit as soon as the electrode contacts the work piece. The welder should always ensure a good connection of the work clamp. The nearer the clamp is placed to the welding area the better.

When the arc is struck the distance between the end of the electrode and the work will determine the arc voltage and also affect the weld characteristic. As a guide the arc length for electrodes up to 3.2mm diameter should be around 1.6mm and over 3.2mm around 3mm.

Upon completion of the weld the welding flux or slag will need to be removed usually with a chipping hammer and wire brush.

Joint form in MMA

In MMA welding, the common basic joint forms: butt joint, corner joint, lap joint & T joint.

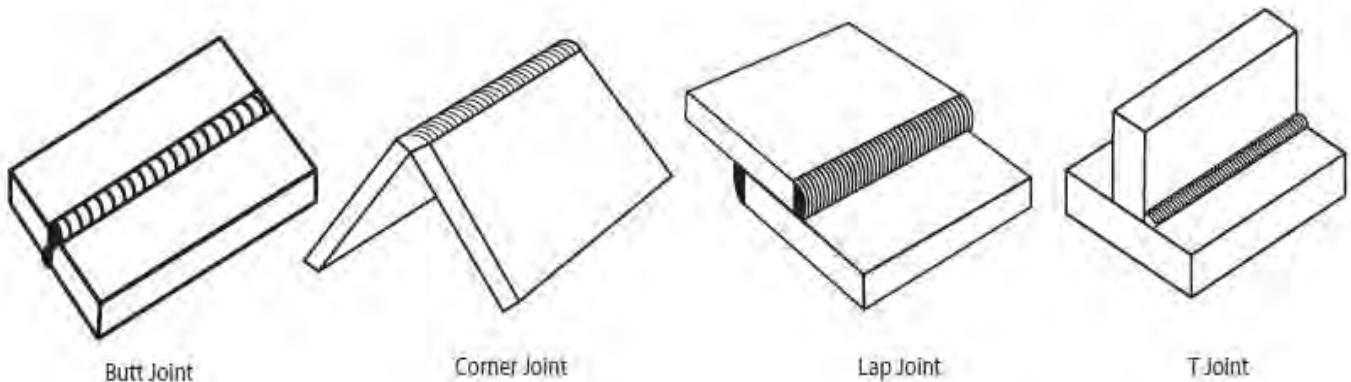

GUIDE TO MMA WELDING



Before starting any welding activity ensure that you have suitable eye protection and protective clothing. Also take the necessary steps to protect any personnel within the welding area.

MMA arc striking

Tap technique - Lift the electrode upright and bring it down to strike the work piece. After forming short circuit, quickly lift up about 2~4mm and arc will be ignited. This method is difficult to master.

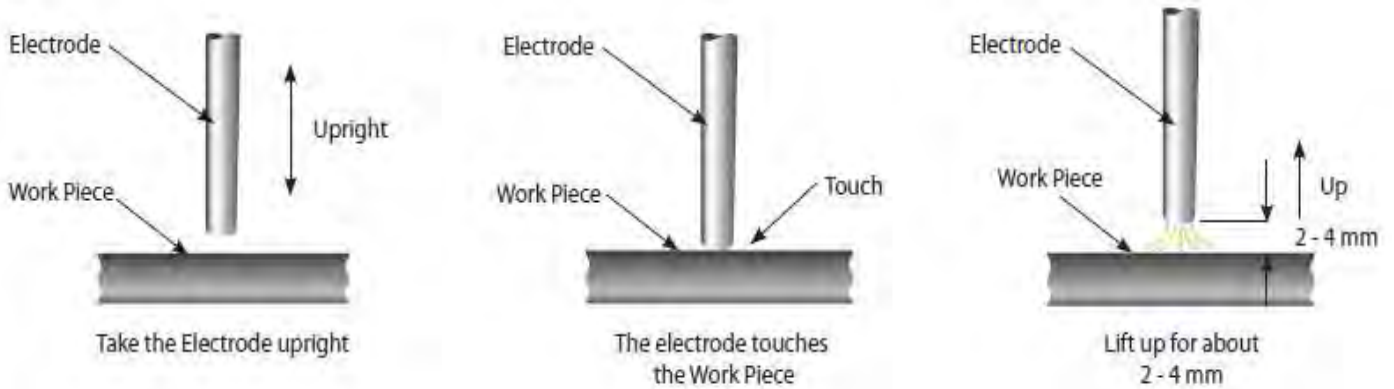

Scratch technique - Drag the electrode and scratch the work piece as if striking a match. Scratching the electrode may cause the arc to burn along the scratch path, so care should be taken to scratch in the weld zone. When the arc is struck adopt the correct welding position.

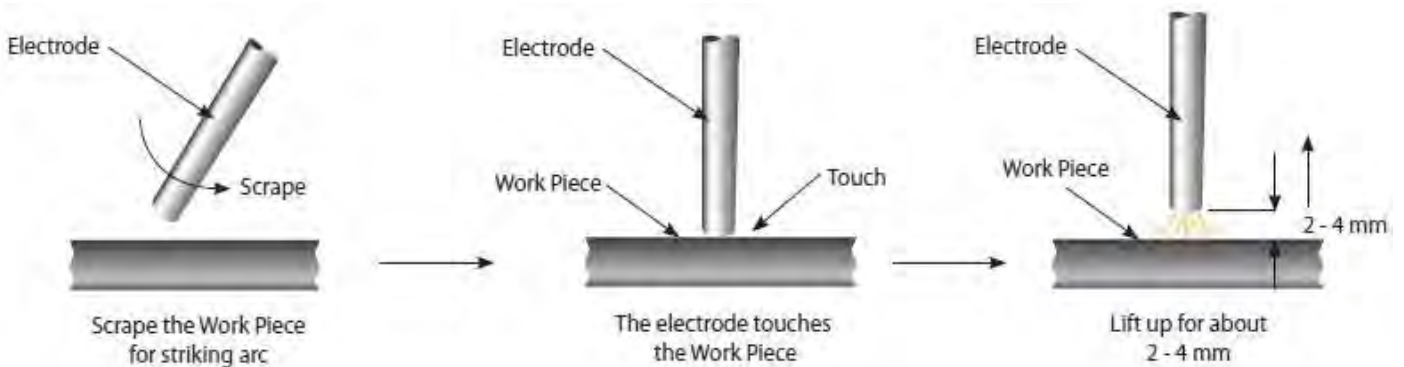

Electrode positioning

Horizontal or flat position

The electrode should be positioned at right angles to the plate and inclined in the direction of travel at around 10°-30°.

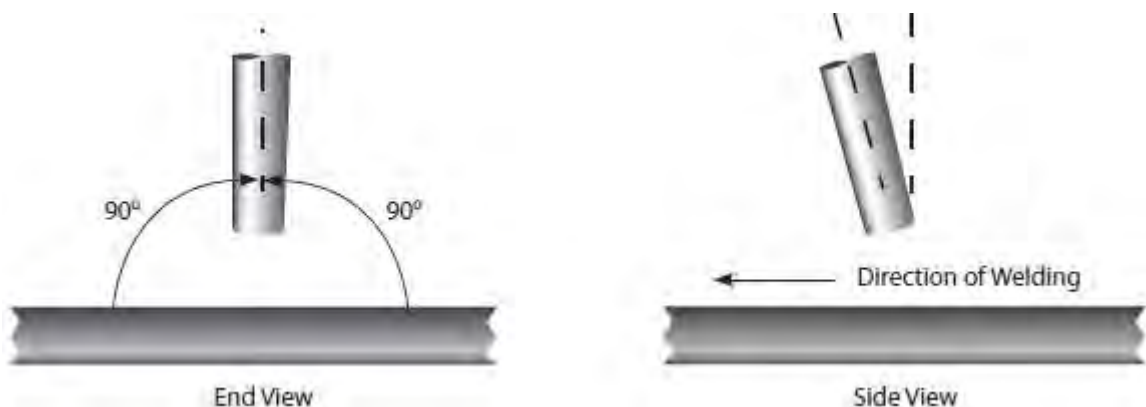

GUIDE TO MMA WELDING



Before starting any welding activity ensure that you have suitable eye protection and protective clothing. Also take the necessary steps to protect any personnel within the welding area.

Fillet welding

The electrode should be positioned to split the angle i.e. 45° . Again the electrode should be inclined in the direction of travel at around 10° - 30° .

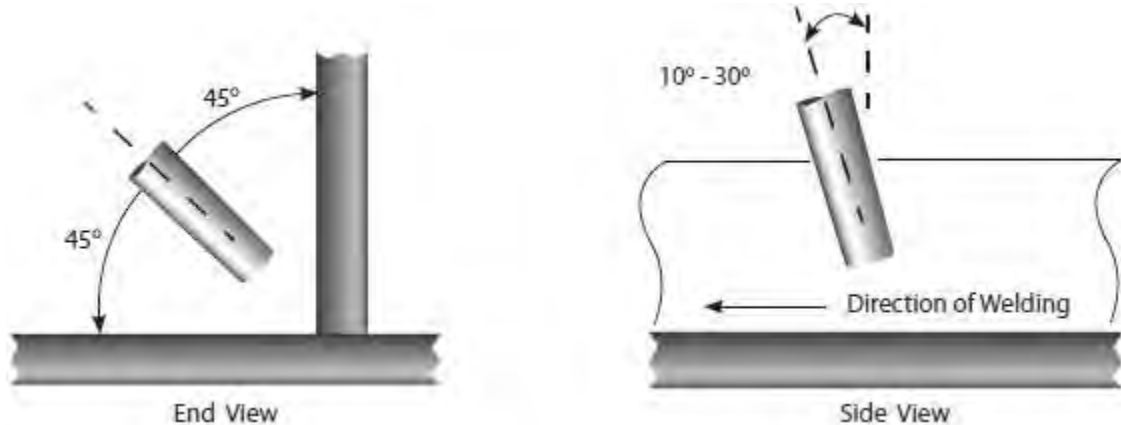

Manipulation of electrode

In MMA welding there are three motions used at the end of electrode:

1. The electrode feeding to the molten pool along axes
2. The electrode swing right and left
3. The electrode moving in the weld direction

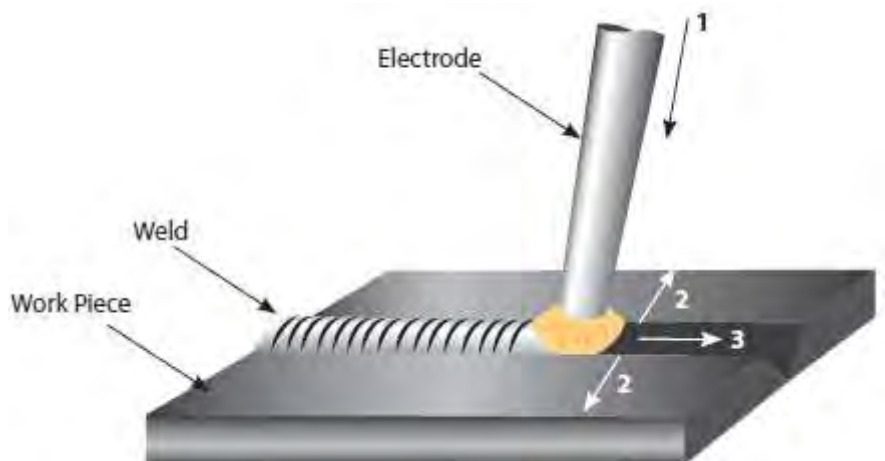

The operator can choose the manipulation of electrode based on welding joint, welding position, electrode spec, welding current and operation skill etc.

Weld characteristics

A good weld bead should exhibit the following characteristics:

1. Uniform weld bead
2. Good penetration into the base material
3. No overlap
4. Fine spatter level

A poor weld bead should exhibit the following characteristics:

1. Uneven and erratic bead
2. Poor penetration into the base material
3. Bad overlap
4. Excessive spatter levels
5. Weld crater

MMA WELDING PROBLEMS



Before starting any welding activity ensure that you have suitable eye protection and protective clothing. Also take the necessary steps to protect any personnel within the welding area.

Arc welding defects and prevention methods

<u>Defect</u>	<u>Possible cause</u>	<u>Action</u>
Excessive spatter (beads of metal scattered around the weld area)	Amperage too high for the selected electrode	Reduce amperage or utilise larger diameter electrode
	Voltage too high or arc length too long	Reduce arc length or voltage
Uneven and erratic weld bead and direction	Weld bead is inconsistent and misses joint due to operator	Operator training required
Lack of penetration – The weld bead fails to create complete fusion between material to be welded, often surface appears okay but weld depth is shallow	Poor joint preparation	Joint design must allow for full access to the root of the weld
	Insufficient heat input	Material too thick Increase the amperage or increase the electrode size and amps
	Poor weld technique	Reduce travel speed Ensure the arc is on the leading edge of the weld puddle
Porosity – Small holes or cavities on the surface or within the weld material	Work piece dirty	Remove all contaminant from the material i.e. oil, grease, rust, moisture prior to welding
	Electrode is damp	Replace or dry the electrode
	Arc length is excessive	Reduce the arc length
Excessive penetration – The weld metal is below the surface level of the material and hangs below	Heat input too high	Reduce the amperage or use a smaller electrode and lower amperage
	Poor weld technique	Use correct welding travel speed
Burning through – Holes within the material where no weld exists	Heat input too high	Use lower amperage or smaller electrode Use correct welding travel speed
Poor fusion – Failing of weld material to fuse either with the material to be welded or previous weld beads	Insufficient heat level	Increase the amperage or increase the electrode size and amperage
	Poor welding technique	Joint design must allow for full access to the root of the weld Alter welding technique to ensure penetration such as weaving, arc positioning or stringer bead technique
	Work piece dirty	Remove all contaminant from the material i.e. oil, grease, rust, moisture prior to welding

MULTIFUNCTIONAL DISPLAY WINDOW - SETTINGS

Welding screen/display explained MU4-1

The 'Settings' parameter adjustment section can be accessed by rotating the control dial (B) until the settings icon is front and centre (as image right shows) then press to enter the setting interface which is shown below.



The settings page is divided into two sections 'general' and 'machine' and to switch between these two tabs simply press button 'C' and the tab selected will be highlighted in red.

Within the general tab you can rotate the control dial 'B' which will scroll the operator through the options of Languages, Brightness, Beeper, Unit, Information, Factory Reset and Program Update and when you press the control dial you will access the chosen option, in the above image case you can see that the 'General' tab and then the 'Language' tab is selected.

You can now select further language options (if available) by rotating the control dial again and pressing the control dial 'C' to confirm your selection.

Pressing the button 'A' will take you back to the main menu.

The below information shows the available options within the settings section.

Options	Welding parameters available by press the control dial	Welding parameters available by rotating the control dial
General	Languages	English (other languages are available by request)
	Screen Brightness	Adjustable between 1 - 10
	Beeper	ON or OFF
	Unit	Metric or Imperial
	Information	Version details
	Factory Reset	Restoring to factory setting
	Program Update	Updating program (USB port)
Machine	Fan	Normal (Permanently on) Smart (Fan on demand)
	Wireless Control	Connecting a Wireless Remote or Wireless Control
	Wire Retract	ON or OFF (see page 9)
	Remote control	Off or Remote

REMOTE CONTROL - WIRED

The MU4-1 is fitted with a 9 pin remote control socket (early models were supplied with a 12 pin socket, see page 62) which is located on the front panel and is used to connect a TIG torch trigger with switch and a 'analogue' type foot pedal* for TIG welding.

The Weld Star TIG welding machine can accept a remote current control signal from a analogue type potentiometer.

* Using a 10K Potentiometer remote control will change the current from 5amp to the maximum setting using the machine panel current control.

When fitting either the 9 or 12 pin remote plug, ensure you align the keyway when inserting the plug, then rotate the threaded collar fully clockwise until finger tight.

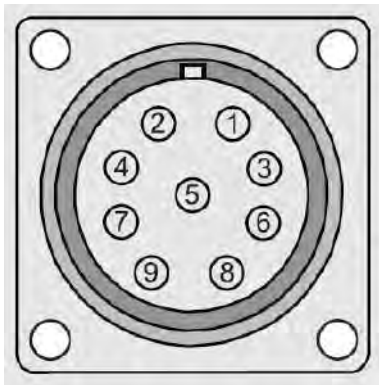

The 9 pin plug and clamp part number is: JSG-PLUG-9PIN

9 Pin Remote socket configuration		
Pin	Description	
1	Potentiometer (max)	10k Potentiometer current control in TIG mode.
2	Potentiometer wiper	
3	Potentiometer (min)	1K Potentiometer speed control in spool gun mode.
4	Link to 5	Fixed link required for foot pedal recognition
5	Link to 4	
6	Spool Gun Motor +	+ Supply voltage for spool gun motor
7	Spool Gun Motor -	- Supply voltage for spool gun motor
8	Trigger switch	Switch signal from a TIG torch switch or footpedal
9	Trigger switch/ground	

9 Pin Remote Control Device Wiring

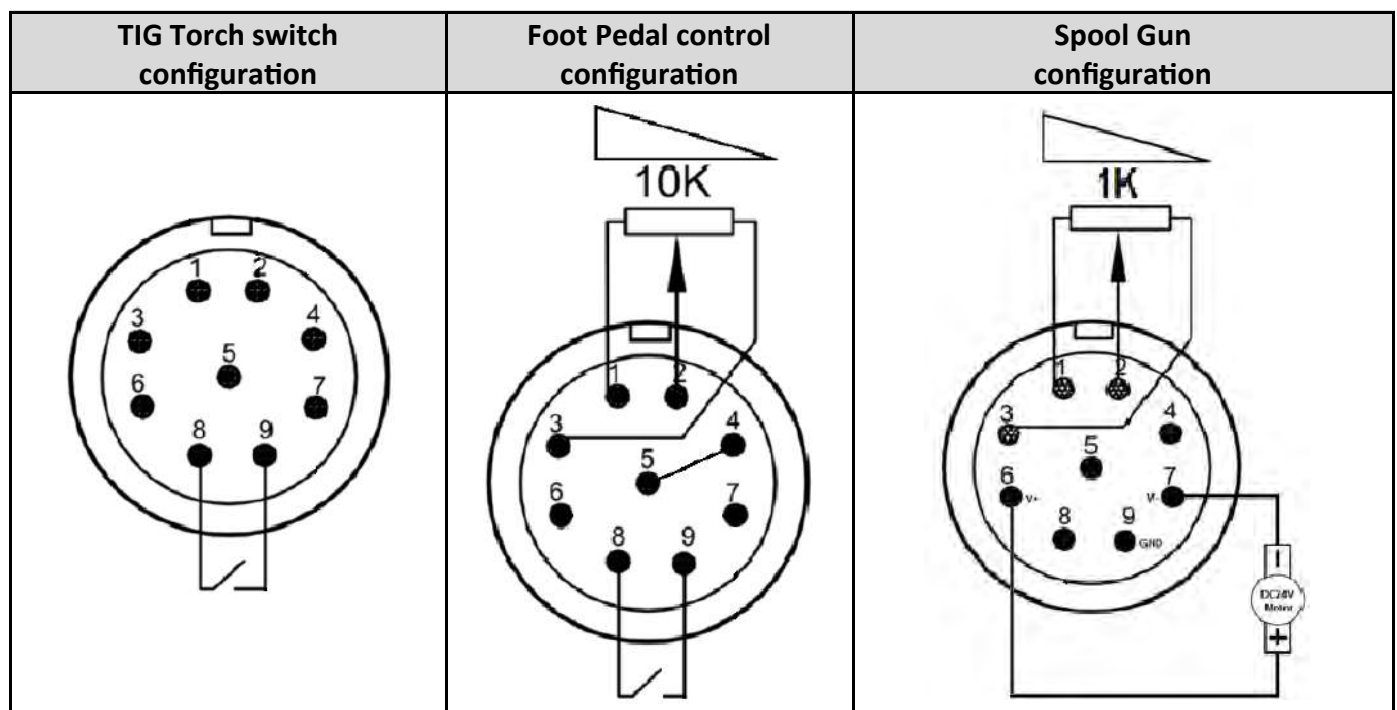

REMOTE CONTROL - WIRED



Before starting any welding activity ensure that you have suitable eye protection and protective clothing. Also take the necessary steps to protect any personnel within the welding area.

12 Pin Remote control socket

On earlier supplied MU4-1 machines a 12 pin remote control socket was fitted which was located on the front panel and is used to connect a TIG torch trigger with switch and/or torch mounted 'analogue' current adjustment dial, a digital type mounted torch control or a foot pedal for TIG welding.

12 Pin Remote socket pin and wiring configuration

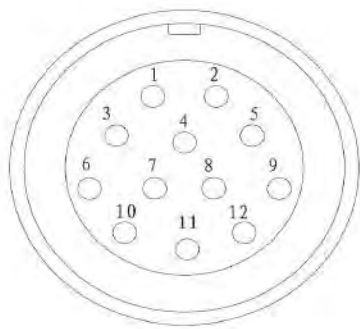

Analogue (potentiometer) type TIG control

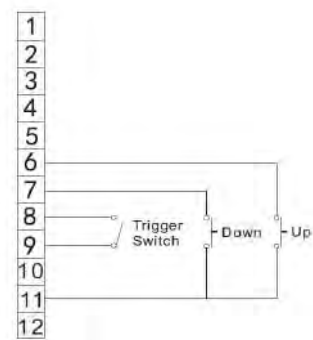
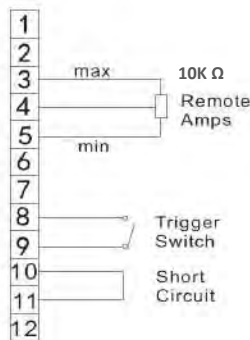

Digital type TIG control

Before starting to use a wired remote control, see page 63 for instructions on activating the remote control function.

TIG torch with remote amperage control via a potentiometer

Connect the TIG torch control plug to the machines remote control socket and place the machine torch trigger mode into 4T (see from page 22).

Press the TIG torch switch to start the machine output functions. The finger controlled torch handle mounted current potentiometer controls the welding amperage (by rotating clockwise/anti clockwise) up to the already pre-set level set on the welding power source control panel.

With a TIG torch current control connected, the machines digital ammeter will display the pre-set preview amps until the torch switch is pressed, when welding commences it will then display actual welding current depending on where your torch mounted potentiometer is positioned.

Foot pedal amperage control

Connect the foot pedal control plug to the machines remote control socket and place the torch trigger mode into 2T (see page 22). Press the foot pedal down to start the machine output functions. The foot control potentiometer controls the welding current up to the preset level set on the welding power source control panel.

With the foot control connected, the panel digital ammeter will display the pre-set preview amps until the foot control is depressed then it displays actual welding current when welding.

Please note:

The maximum output current must be set on the power source control panel by the user prior to the foot control being connected.

REMOTE CONTROL - WIRELESS



Before starting any welding activity ensure that you have suitable eye protection and protective clothing. Also take the necessary steps to protect any personnel within the welding area.

Wireless control

The Weld Star WS-MU4-1 is equipped with in-built wireless technology and can accept a wireless remote foot current control signal from a wireless foot pedal which offers greater flexibility to the operator.

Please follow the below instruction on pairing a wireless remote control.

The 'Settings' parameter adjustment section can be accessed by rotating the control dial (B) until the settings icon is front and centre (as image right shows) then press to enter the setting interface which is shown below right.

The settings page is divided into two sections 'general' and 'machine' and to switch between these two tabs, when machine is highlighted press button 'C' and the Machine tab will now be highlighted in red.

Within the machine tab you can rotate the control dial 'B' which will scroll through machine options of Fan, Wireless, Wire Retract and Remote Control, press the control dial when Wireless is highlighted to access.

Once in the wireless connect menu screen you will see the options to choose from:

- Wireless Foot Pedal 'unconnected'
- Wireless Remote Control 'Unconnected'

At this point, turn ON your optional wireless foot pedal.

On the wireless menu screen, highlight and select 'wireless remote control' and the screen will change to say 'Connecting' and shows an image of a foot pressing down on a foot pedal.

As shown, now press down on the foot pedal which will start the pairing process.

Once the machine and the foot pedal have connected the screen will show 'paired successfully' and show 'Connected' under the wireless foot pedal image.

Turning remote control ON and OFF

Once you have either connected a Wired or Wireless remote control, you now need to the remote control command from panel to remote and you do this by selecting, setting, machine and then the Remote Control option icon on the left side of the screen, once in this option menu you will be able to ON (or OFF) remote control. ON for remote control and OFF for panel current control.

Pressing button 'A' will save your settings and take you back to the main menu screen.

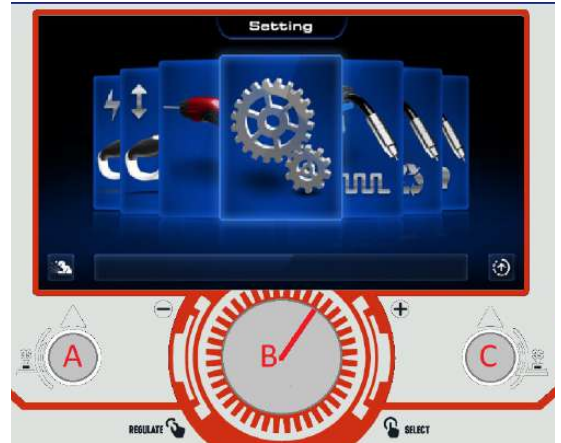

MAINTENANCE



The following operation requires sufficient professional knowledge on electrical/electronic aspects and comprehensive safety knowledge.

Make sure the input cable of the machine is disconnected from the electricity supply and wait for 5 minutes before removing the machine covers.

In order to guarantee that the arc welding machine works efficiently and safely, it must be maintained regularly. Operators should understand the maintenance methods and be conversant with operating arc welding machines. This guide should enable customers to carry out simple examination and safeguarding by themselves, so as to reduce the fault rate and repair times of the arc welding machine, and so lengthen service life of the MIG welding machine.

Period

Maintenance item

Daily examination	<ul style="list-style-type: none"> • Check the condition of the machine, mains cables, welding cables and connections • Check for any warnings LEDs and machine operation
Monthly examination	<ul style="list-style-type: none"> • Disconnect from the mains supply and wait for at least 5 minutes before removing the cover • Check internal connections and tighten if required • Clean the inside of the machine with a soft brush and vacuum cleaner • Take care not to remove any cables or cause damage to components • Ensure that ventilation grills are clear • Carefully replace the covers and test the unit <p>This work should be carried out by a suitably qualified competent person</p>
Yearly examination	<ul style="list-style-type: none"> • Carry out an annual service to include safety check in accordance with the manufacturers standard (EN 60974-1) <p>This work should be carried out by a suitably qualified competent person</p>

⇒ **Ensure the power is disconnected before working on the machine.**

⇒ **Always wait 5 minutes after power switch off before opening the case.**

SERVICE SCHEDULE RECORD

Date	Type of service and work carried out	Serviced by	Due date for next check

TROUBLESHOOTING



The following operation requires sufficient professional knowledge on electrical/electronic aspects and comprehensive safety knowledge.

Make sure the input cable of the machine is disconnected from the electricity supply and wait for 5 minutes before removing the machine covers.

Before arc welding machines are dispatched from the factory, they have already been checked thoroughly. The machine should not be tampered with or altered. Maintenance must be carried out carefully. If any wire becomes loose or is misplaced, it maybe potentially dangerous to the user!

Only professional maintenance personnel should repair the machine!

Ensure the power is disconnected before working on the machine. Always wait 5 minutes after power switch off before removing the panels.

Description of fault	Possible cause
The digital display is OFF and the fan is not functioning	The primary supply voltage has not been switched ON or input fuse has blown
	The welding power source input switch is switched OFF
	Loose connections internally
The digital display is ON but the fan is not running	The machine fan blades may be jammed
	The machine fan may not be functional
	Check the wiring and the supply voltage to the fan
Wire feed motor does not rotate when the MIG torch trigger switch is depressed	Check wire feed speed, to ensure its not set to zero
	Check supply to wire feed motor
	Possible motor PCB fault
Output current reduces when welding	Poor work lead connection to the work piece
TIG electrode melts when arc is struck	TIG torch is connected to the (+) VE terminal
No gas flow when the MIG torch trigger switch is depressed	Empty gas cylinder
	Gas regulator is turned off
	Gas hose is blocked or cut
	Torch trigger switch lead is disconnected or switch/lead is faulty
Difficult to ignite the arc	The welding voltage is too low or the wire feed speed is set too high
The electrode holder becomes very hot	The rated current of the electrode holder is smaller than its actual working current, replace it with a higher rated current capacity
Excessive spatter in MMA welding	The output polarity connection is incorrect, exchange the polarity
Other malfunction	Contact your supplier
Overheat error code lights up	Let the machine cool, it will automatically start again
	Insufficient cooling air
	Cooling fan is not running
Wire continues to feed through when the MIG torch switch is released	The trigger mode switch is set to 4T rather than 2T
	Faulty MIG torch switch
Machine error codes	See the following troubleshooting page for further detail on error codes (page 66)

ERROR CODES



The following operation requires sufficient professional knowledge on electrical/electronic aspects and comprehensive safety knowledge.

Make sure the input cable of the machine is disconnected from the electricity supply and wait for 5 minutes before removing the machine covers.

Before arc welding machines are dispatched from the factory, they have already been checked thoroughly. The machine should not be tampered with or altered. Maintenance must be carried out carefully. If any wire becomes loose or is misplaced, it maybe potentially dangerous to the user!

Only professional maintenance personnel should repair the machine!

Ensure the power is disconnected before working on the machine. Always wait 5 minutes after power switch off before removing the panels.

Error Type	Error code	Description	Lamp status
Thermal relay	E01	Over-heating(1st thermal relay)	Yellow lamp (thermal protection) always on
	E02	Over-heating(2nd thermal relay)	Yellow lamp (thermal protection) always on
	E03	Over-heating(3rd thermal relay)	Yellow lamp (thermal protection) always on
	E04	Over-heating(4th thermal relay)	Yellow lamp (thermal protection) always on
	E09	Over-heating (Program in default)	Yellow lamp (thermal protection) always on
Welding machine	E10	Phase loss	Yellow lamp (thermal protection) always on
	E11	No water	Yellow lamp (lack of coolant) always on
	E12	No gas	Red lamp always on
	E13	Under voltage	Yellow lamp (thermal protection) always on
	E14	Over voltage	Yellow lamp (thermal protection) always on
	E15	Over current	Yellow lamp (thermal protection) always on
	E16	Wire feeder over load	-
Switch	E20	Button fault on operating panel when switch on the machine	Yellow lamp (thermal protection) always on
	E21	Other faults on operating panel when switch on the machine	Yellow lamp (thermal protection) always on
	E22	Torch fault when switch on the machine	Yellow lamp (thermal protection) always on
	E23	Torch fault during normal working process	Yellow lamp (thermal protection) always on
Accessory	E30	Cutting torch disconnection	Red lamp blink
	E31	Water cooler disconnection	Yellow lamp (lack water) always on
Communication	E40	Connection problem between wire feeder and power source	-
	E41	Communication error	-

ELECTRICAL SCHEMATIC



The following operation requires sufficient professional knowledge on electrical/electronic aspects and comprehensive safety knowledge.

Make sure the input cable of the machine is disconnected from the electricity supply and wait for 5 minutes before removing the machine covers.

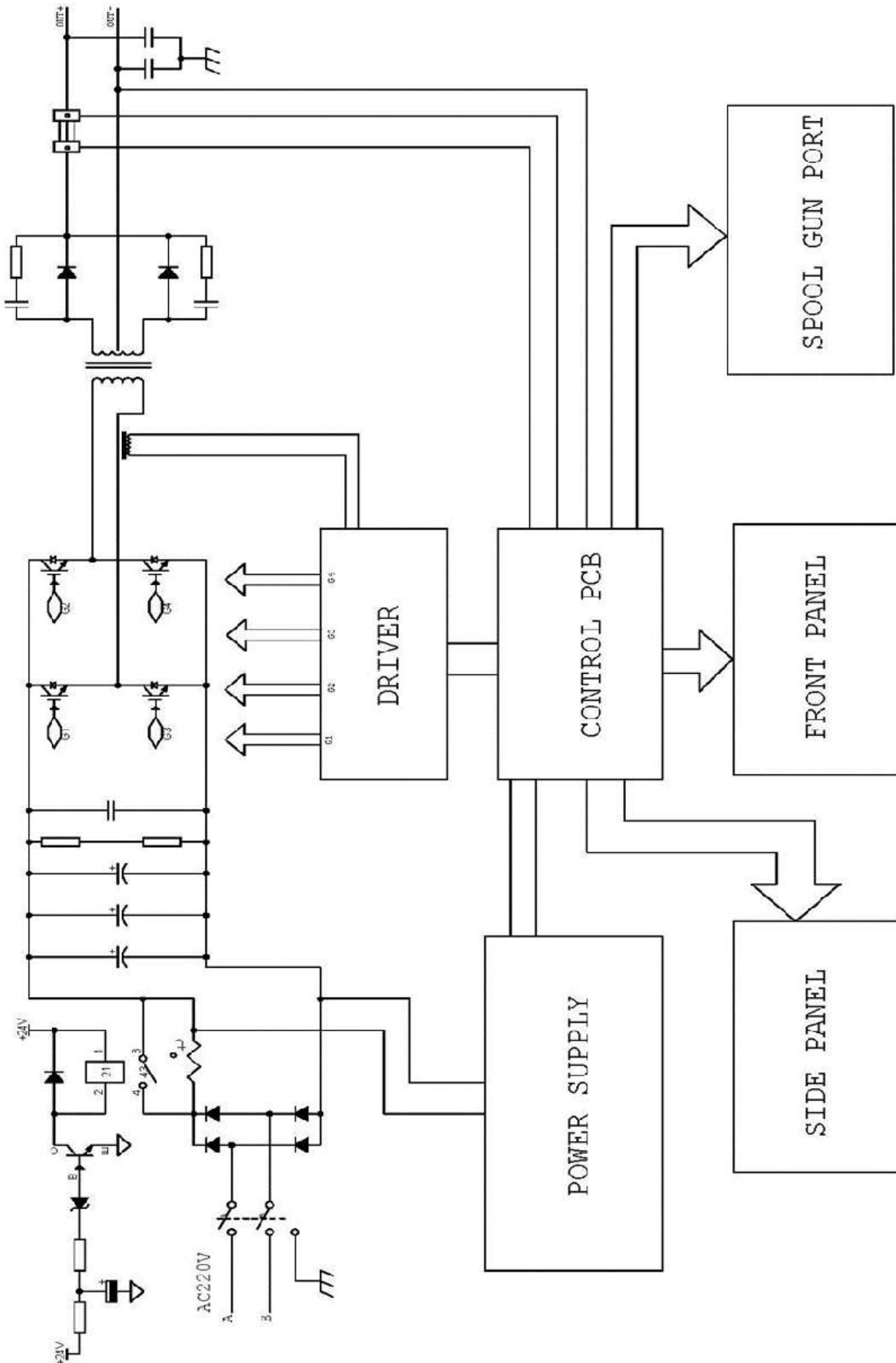

WEEE disposal

The equipment is manufactured with materials which do not contain any toxic or poisonous materials dangerous to the operator.

When the equipment is scrapped, it should be dismantled separating components according to the type of materials.

Do not dispose of the equipment with normal waste. The European Directive 2002/96/EC and United Kingdom's Directive The Waste Electrical and Electronic Equipment (WEEE) regulations 2013 states that electrical equipment that has reached its end of life must be collected separately and returned to an environmentally compatible recycling facility.

Weld Star has a relevant recycling system which is compliant and registered in the UK with the environment agency. Our registration reference is WEEMM3813AA.

In order to comply with WEEE regulations outside the UK you should contact your supplier.

RoHS Compliance Declaration

We herewith confirm that the above mentioned product does not contain any of the restricted substances as listed in EU Directive 2011/65/EU and the UK directive ROHS Regulations 2012 in concentrations above the limits as specified therein.

UKCA Declaration of Conformity

The manufacturer, or its legal representative Wilkinson Star Limited, declares that the equipment described below is designed and produced according to following UK legislation:

- Electrical equipment safety 2016
- Electromagnetic compatibility (EMC) regulations 2016
- The restrictions of the use of certain hazardous substances in electrical and electronic equipment regulations 2012

And inspected according to following designated standards:

- EN 60 974-1:2018+A1:2019
- EN 60 974-10:2014+A1:2015

Any alteration or change to these machines by any unauthorized person makes this declaration invalid.

Model:

Weld Star WS-MU4-1 ACDC

Authorised Representative:

Wilkinson Star Limited
Shield Drive
Wardley Industrial Estate
Worsley
Manchester
M28 2WD

Disclaimer:

Please note that this confirmation is given to the best of our present knowledge and belief.

Nothing herein represents and/or may be interpreted as warranty within the meaning of the applicable warranty law.



EC DECLARATION OF CONFORMITY

The manufacturer, or its legal representative **Wilkinson Star Limited**, declares that the equipment described below is designed and produced according to following EU Directives:

- Low Voltage Directive (LVD), No.: 2014/35/EU
- Electromagnetic compatibility (EMC) Directive, No.: 2014/30/EU

And inspected according to following
EU - Norms:

- EN 60 974-1:2012
- EN 60 974-10:2014+A1

Any alteration or change to these machines by any unauthorized person makes this Declaration invalid.

Wilkinson Star model

Weld Star WS-200P ACDC

Authorised Representative

Wilkinson Star Limited
Shield Drive,
Wardley Industrial Estate
Worsley
Manchester
M28 2WD

Signature

Dr John A Wilkinson OBE

Position Chairman

Date



Company stamp

STATEMENT OF WARRANTY

All Weld Star welding, plasma multi-process machines sold through our partner Wilkinson Star Ltd within the United Kingdom, Ireland and Europe shall be warranted to the original owner, non transferable, against failure due to defective materials or production.

The warranty period is 5 years following the date of purchase.

We recommend you register your product within 28 days of purchase via the registration page via the Weld Star product website www.weldstar.uk

The original invoice is documentation for the standard warranty period.

The warranty period is based on a single shift pattern.

Defective units shall be repaired or replaced by the company at our workshop.

The company may opt to refund the purchase price (less any costs and depreciation due to use and wear).

The company reserves the right to alter the warranty conditions at any time with effect for the future.

A prerequisite for the full warranty is that products are operated in accordance with the operating instructions supplied, observing the relevant installation and any legal requirements recommendations and guidelines and carrying out the maintenance instructions shown in the Weld Star operator manual. This should only be carried out by a suitably qualified competent person.

In the unlikely event of a problem, this should be reported to the Wilkinson Star Ltd technical support team to review the claim.

The customer has no claim to loan or replacement products whilst repairs are being performed.

The following falls outside the scope of the warranty:

- Defects due to natural wear and tear
- Failure to observe the operating and maintenance instructions
- Connection to an incorrect or faulty mains supply
- Overloading during use
- Any modifications that are made to the product without the prior written consent
- Software errors due incorrect operation
- Any repairs that are carried out using non-approved spare parts
- Any transport or storage damage
- Direct or indirect damage as well as any loss of earnings are not covered under the warranty
- External damage such as fire or damage due to natural causes e.g. flooding

NOTE:

Under the terms of the warranty, welding torches, their consumable parts, wire feed unit drive rolls and guide tubes, work return cables and clamps, electrode holders, connection and extension cables, mains and control leads, plugs, wheels, coolant etc. are covered with a 3 month warranty.

Wilkinson Star Ltd shall in no event be responsible for any third party expenses or expenses/costs or any indirect or consequential expenses/costs.

Wilkinson Star Ltd will submit an invoice for any repair work performed outside the scope of the warranty. A quotation for any non warranty will be raised prior to any repairs being carried out.

The decision about repair or replacement of the defective part(s) is made by Wilkinson Star Ltd. The replaced part(s) remain(s) Wilkinson Star Ltd property.

Warranty extends only to the machine, its accessories and parts contained inside.

No other warranty is expressed or implied.

No warranty is expressed or implied in regards to the fitness of the product for any particular application or use.

OPTIONS AND ACCESSORIES

Part Number	Description
T240-3 *	MIG Torch 3mtr Euro
T240-4	MIG Torch 4mtr Euro
T240-5	MIG Torch 5mtr Euro
WCS25-3LDT *	Welding Cable Set (MMA) 3m
WC-2-03LD	Electrode Holder and Lead 3m
EC-2-03LD	Work Return Lead and Clamp 3m
TIG-103	Titanium 26 TIG Torch 12.5ft c/w 12 pin plug and Dinse adaptor
JE79-ERGO *	Titanium 26 TIG Torch, 12.5ft c/w 9 pin plug and Dinse adaptor
CP3550	Cable Plug 35-50mm
SSARG2G *	Single Stage 2 Gauge Argon Regulator
CRH14 *	2mtr Gas Hose
WS-T2	2 Wheel Trolley
10055168	"V" Groove 0.6mm/0.8mm
10036428 *	"V" Groove 0.8mm/1.0mm
10039481	"V" Groove 1.0mm/1.2mm
10029899	"U" Groove 0.8mm/1.0mm
10016532	"U" Groove 1.0mm/1.2mm
WS-WFCP	Wired Foot Pedal (9 Pin control plug)
WS-WLFCP	Wireless Foot Pedal
* Supplied as standard with new machine package	

MEMORY STORAGE

Use the below section to list your stored program channel numbers that you have created and stored for specific welding tasks.

Channel Memory	Welding process MMA, MIG or TIG	Job number or Description of welding job
C00		
C01		
C02		
C03		
C04		
C05		
C06		
C07		
C08		
C09		
C10		

WELD STAR | INFINIUM

Wilkinson Star Limited

Shield Drive
Wardley Industrial Estate
Worsley
Manchester
M28 2WD

+44(0)161 793 8127

wilkinsonstar247.com

50 / A family business
engineered through
generations **since 1971**

E&OE

October 2023 Issue 5