



Gas Control Equipment



CYLINDER PRESSURE REGULATOR FOR INDUSTRIAL GAS APPLICATIONS

GCE SmartControl

GCE SmartControl - a reliable choice for diverse industrial cutting and welding operations. Its streamlined, lightweight design, coupled with precise internal gas regulation, guarantees operators a steady gas supply and accurate pressure control.

Available in multiple configurations, compatible with prevalent cylinder valves, accommodating inlet pressures up to 230 Bar.

Crafted in compliance with ISO 2503 standards, ensuring quality design and manufacturing.



PRODUCT FEATURES

- Cylinder regulator applicable for all common industrial gas applications; suitable for welding, cutting and heating as well as shielding gas applications
- **Precise, safe and reliable**
- **Large 54mm diaphragm**
- Safety focused design following **ISO 2503**
- **Compact, durable construction** saving costs related to services, spares and replacements
- Easy handling for the operator by ergonomic arrangement
- Standard horizontal bonnet set up “Mickey Mouse” style, compatible with all common cylinder valves, variability of connection
- **50mm three scale pressure gauges to ISO 5171 with high contrast pointer for better gas pressure clarity**
- Colour coded decals for quick and easy identification

TECHNICAL DATA

Gas	O ₂ , N ₂ , H ₂ , He	Ar, Ar/CO ₂	CO ₂	Acetylene	Propane
Body	Brass forged				
Bonnet	Zn/Al alloy Die Cast				
Stems, nuts and fittings	Brass				
Diaphragm	EPDM			NBR	
Seat sealing	PA			CR	
Inlet/ Outlet connection	Gas specific connection				
Maximal inlet pressure	230 bar		200 bar	25 bar	
Outlet pressure/ flow range	0-10 bar	0-16l/min 0-30 l/min 0-40l/min		1,5 bar	4 bar
Temperature range	From -20°C to 60°C				
Weight	Approx. according to gas variant: 1,35 kg				

PRODUCT ADVANTAGES

50 mm Triple scale gauges
According to ISO 5171, with high contrast pointer for better gas pressure clarity.

Accurate parameter setting with an optimized pressure adjusting mechanism.

Regulating technology for precise parameters and stability, tested for many years.

Colour coded handwheel
Simple identification of the gas, ergonomic and robust design, easy handling for the operator.

Inlet connection
Side and bottom entry variants available, variants fit on all types of cylinder valves.



FLOW CHARTS

Oxygen 200/10 bar

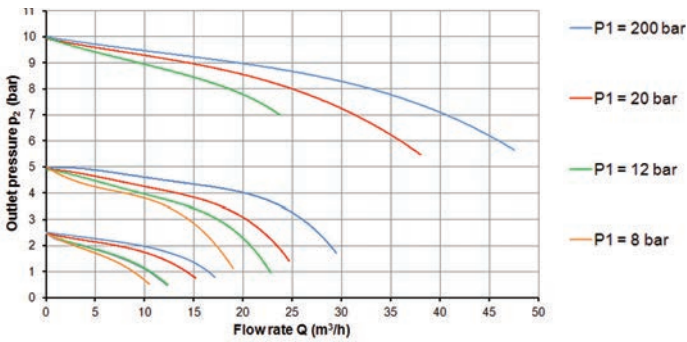

Acetylene 25/1,5 bar

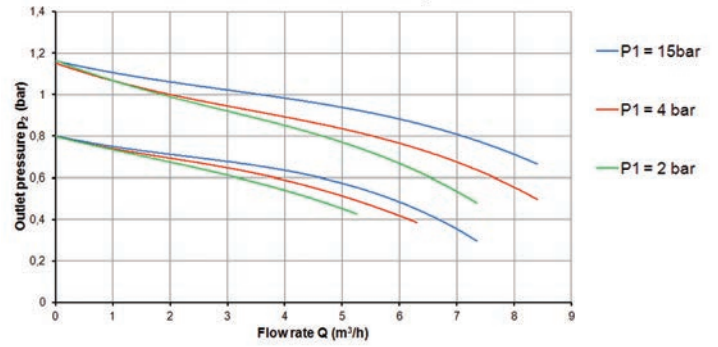

Propane 25/ 4 bar

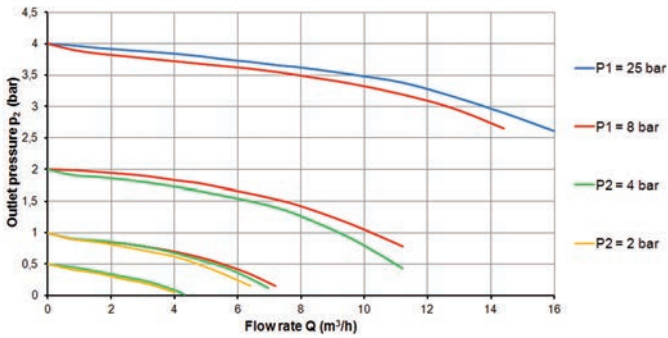

Conversion coefficient

Test gas	Air	Oxygen	Nitrogen	Argon	Hydrogen	Helium	CO ₂
Air	1	0,950	1,02	0,851	3,81	2,695	0,808

Flow of the gas (A)

$$A = Q \cdot f$$

Q... Air Flow

f... Conversion coefficient

STABILITY COEFFICIENT CURVE

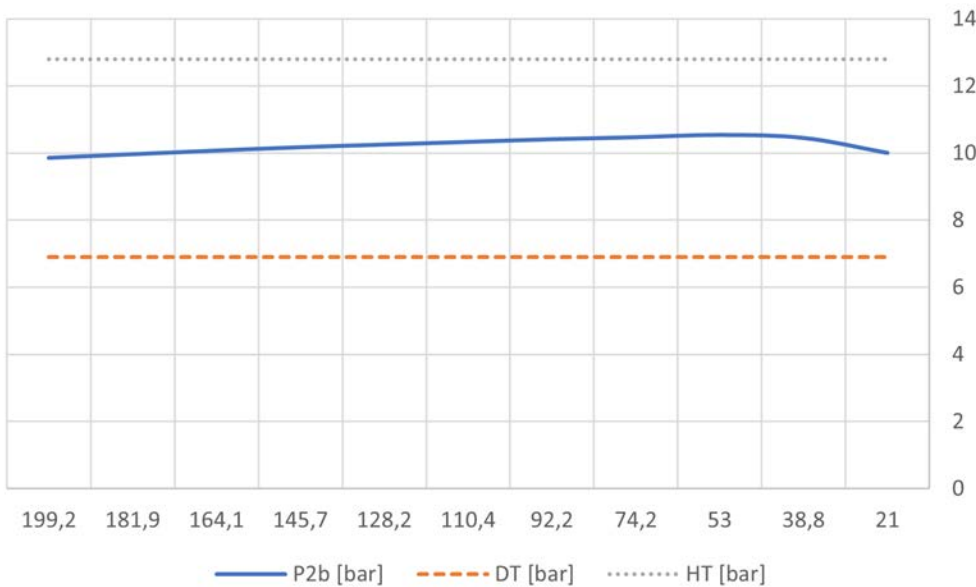

DIMENSIONS

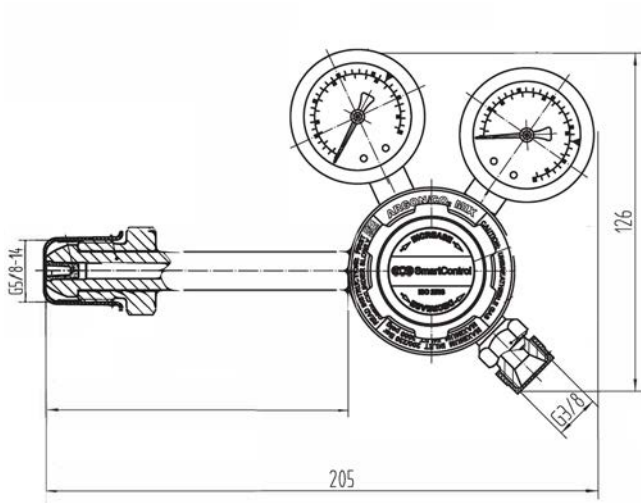

ORDERING INFORMATION

Article number	Gas	Inlet pressure	Outlet pressure	Inlet connection	Outlet connection	Type
S21620005	OXYGEN	230 bar	10 bar	G5/8 BS341	G3/8" RH	Side Entry
S21620006	ACETYLENE	25 bar	1.5 bar	G5/8 LH BS341	G3/8" LH	Side Entry
S21620007	ARGON/CO2	230 bar	30 l/min	G5/8 BS341	G3/8" RH	Side Entry
S21620008	OXYGEN	230 bar	10 bar	G5/8" RH	G5/8 BS341	Bottom Entry
S21620009	ACETYLENE	25 bar	1,5 bar	G5/8" LH	G5/8 LH BS341	Bottom Entry
S21620010	ARGON/CO2	230 bar	30l/min	G5/8" RH	G5/8 BS341	Bottom Entry
S21620011	PROPANE (LPG)	25 bar	4 bar	G5/8" LH	G5/8 LH BS341	Side Entry