

FL20

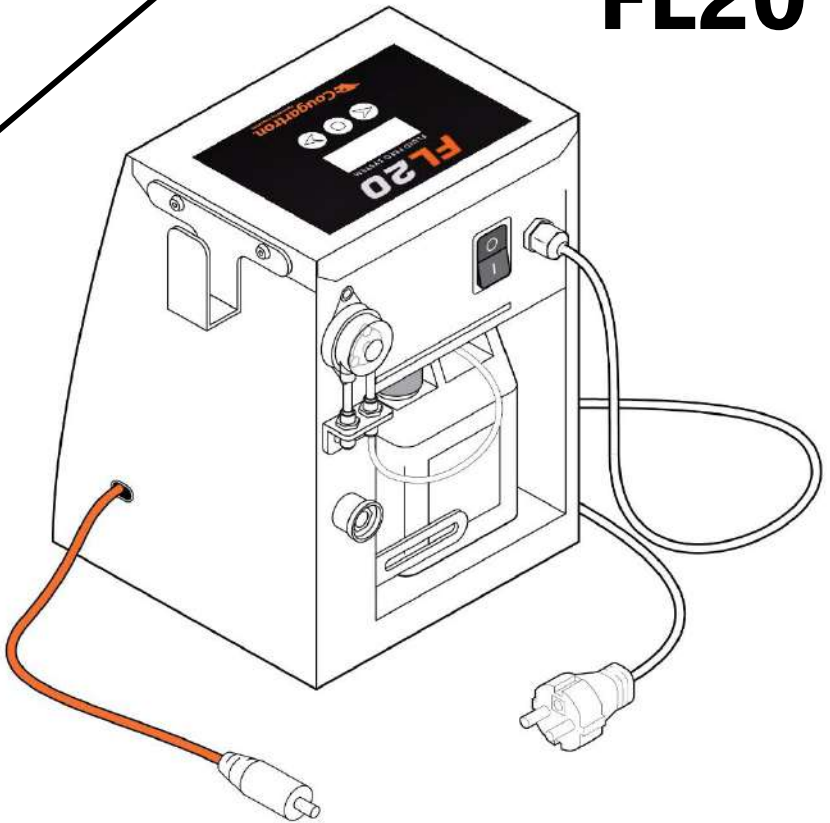

USER MANUAL

Congratulations

Dear Customer,

Thank you for purchasing Cougartron FL20 Fluid Feed Machine.

We would like to reward you with an exclusive extended 2-year warranty!

To qualify for this, please fill in the information below and send it to us by **email:** warranty@cougartron.com Or **register online** at: <https://cougartron.com/machine-support/>

Machine Model: FL20	Serial Number:	Date of Purchase:
Customer Name:		
Phone Number:	Customer Email:	
Customer Address:		
Distributor Name and Address:		



Scan the QR Code
to register your
machine online

We love hearing from our customers and are very happy to help if you have any feedback or questions.

Best Regards,

The Cougartron Team

Foreword

This User Manual is very important. Please read the user manual before using the machine. Keep it with the machine at all times.

The purpose of this manual is to provide users with the necessary operating procedures and precautions essential for the safe and proper operation of the Cougartron FL20 Fluid Feed Machine.

Due to our policy of continuous improvement, BM Group International ApS reserves the right to make specification changes and user manual updates. The latest version can be downloaded from www.cougartron.com

You can find your local distributor by contacting:

Europe:

Cougartron / BM Group International
ApS
Brydehusvej 23
2750 Ballerup, Denmark
sales@cougartron.com
+45 4346 2010

North America:

Cougartron Inc.
PO Box 250
142 Glen Mills Rd
Glen Mills
PA 19342, United States
sales@cougartron.com
+1 404-591-8920

Table of Contents

1.	Introduction	1
2.	Technical Specification	2
3.	Warning Symbols.....	3
4.	Safety Information.....	4
5.	Description of Apparatus.....	6
5.1	FL 20 Control Panel.....	6
5.2	FL 20 Current Clamp.....	7
5.3	FL20 Handle and Wand.....	8
6.	Cleaning Method	Error! Bookmark not defined.
6.1	Preparation.....	9
6.2	Assembly of the FL20.....	Error! Bookmark not defined.
6.3	Cleaning Fluid	13
6.4	Operation.....	13
7.	FL 20 Pump Settings.....	14
8.	Maintenance	15
9.	Consumables	16
9.1	Cougartron Brushes.....	16
9.2	Cougartron Shrouds.....	16
9.3	Cougartron Fluids.....	16
10.	Troubleshooting.....	17
10.1	Fluid not delivered but pump turning	17

10.2 LCD Display not illuminated	17
11. Warranty.....	18

1. Introduction

The Cougartron FL20 is a fluid pump unit which is designed to work with Power 30, Power 30x and Proplus weld cleaning units. It enables the user to control the amount of CGT- 550 or CGT- 350 which is delivered to the brush and there by speeding up the cleaning process.

The Cougartron FL20 comprises a pump unit, which attaches to the machine, cleaing handle, wand and lead which delivers fluid to the brush tip. This unique cleaning system is quick, eliminates the need for pickling paste, or abrasives, and provides a superior finish.

The Cougartron CGT- 550 and CGT- 350 cleaning fluid is based on phosphoric acid and supplies may be purchased from your Cougartron distributor in 1 liter or 5-liter containers.

The Cougartron FL20 is light and portable, and powered by a 115 or 240 vac mains power source only (refer to Table 1 on page 2). The Cougartron FL20 is provided with a one-year warranty on the control box, provided unit is used only for the purpose for which it is designed. Cougartron accessories (brushes, insulating shrouds and leads) are not covered by the warranty.

If the equipment is used in a manner that the manufacturer does not specify, the safety of the equipment may be impaired, and the warranty invalidated.



2. Technical Specification

Please refer to the details below before plugging Fluid Feed FL20 in and using it. It is important that these specifications are read and understood by the user.

The equipment must be used with the mains supply cord supplied.

- For indoor use.
- For use at altitudes below 2000m.
- Operating temperature between 5 °C - 40 °C (41 - 104 °F)
- IP54 rated enclosure.

Table 1

Part Code	Model	Input
WELC1060	FL20 50/60Hz	110 – 230v

The machine can be used with a 110-120vac or 220-240vac power supply.

3. Warning Symbols



Read Instructions and complete manual before use.



Not to be used near a fire or naked flame.
Serious damage could occur.



To be disposed of according to the WEEE directive.

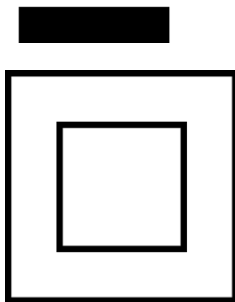

All the electronics in this equipment are double insulated.

4. Safety Information

Protect yourself and others by observing all safety information, warnings and cautions. Failure to comply with instructions could result in personal injury and/or damage to the product or property.

Please retain these instructions for future reference.

Before using the Cougartron FL20, make sure the work environment is well ventilated and away from any combustible substances. Ensure that all required equipment is available.

The Cougartron FL20 is amongst the safest appliances in its class. However, some precautions must be taken with the use of the Cougartron FL20, as with any fluid pump.

- The Cougartron FL20 uses mild acids; gloves should be used to avoid prolonged contact with any of the fluids.
- Goggles should be worn to prevent fluid being splashed in the eyes.
- Fluid spilled on the skin should be washed off as soon as practical.
- Material Safety Data Sheets are available for all fluids and should be read before use.
- The brush, on the weld cleaner, gets extremely hot, around 200°C (392°F) Do not touch the brush. Do not place the brush near any flammable materials.

- When using the Cougartron FL20 and weld cleaner, an electric current is produced by the weld cleaner which may generate small sparks between the brush and the metal being cleaned.
- Hydrogen gas may also be generated (which is an invisible but explosive gas). Always use the apparatus in a well-ventilated area. Do not use near flammable substances, or in areas where dense flammable gases (such as petrol vapor) may accumulate.

- The Cougartron FL20 uses 110 or 240vac mains power source only. Do not use with any other voltage. If the power cord is damaged or if the Cougartron FL20 has been damaged, do not use the unit. Contact your Cougartron distributor to have the Cougartron FL20 inspected and repaired.
- Do not short out the terminals, doing so may permanently damage the Cougartron FL20 .
- Ensure that the Cougartron FL20 is located safely where it cannot fall. Ensure that the cables do not present a trip hazard.

5. Description of Apparatus

5.1 FL20 Control Panel

The mains power ON/OFF switch is on the rear of the unit.

The Control Panel is on the top of the Cougartron FL20 containing the priming, manual and auto settings. It also has a diagnostic function.

The different functions alter the pump speed of the Cougartron FL20.

Click the center button to alternate between the manual and auto settings.

Center button



Once in the manual setting, press and hold to get the priming function. In this setting the pump at 100% for 120secs.

When in manual setting the left button decreases the pump speed in 5% increments and the right button increases the pump speed in 5% increments.

The 5 preprogrammed auto setting deliver fluid according to current draw.

Most applications will have the correct amount of fluid delivered on setting 1 and it can be further reduced using setting 2-5.

5.2 FL20 Current Clamp

The current clamp is already fixed around the orange lead which is to be plugged into the weld cleaner and detects current draw in the auto setting. When the brush is touched on the workpiece the current is detected and the pump starts to deliver fluid. Once the contact with

the workpiece stops the pump switches off.

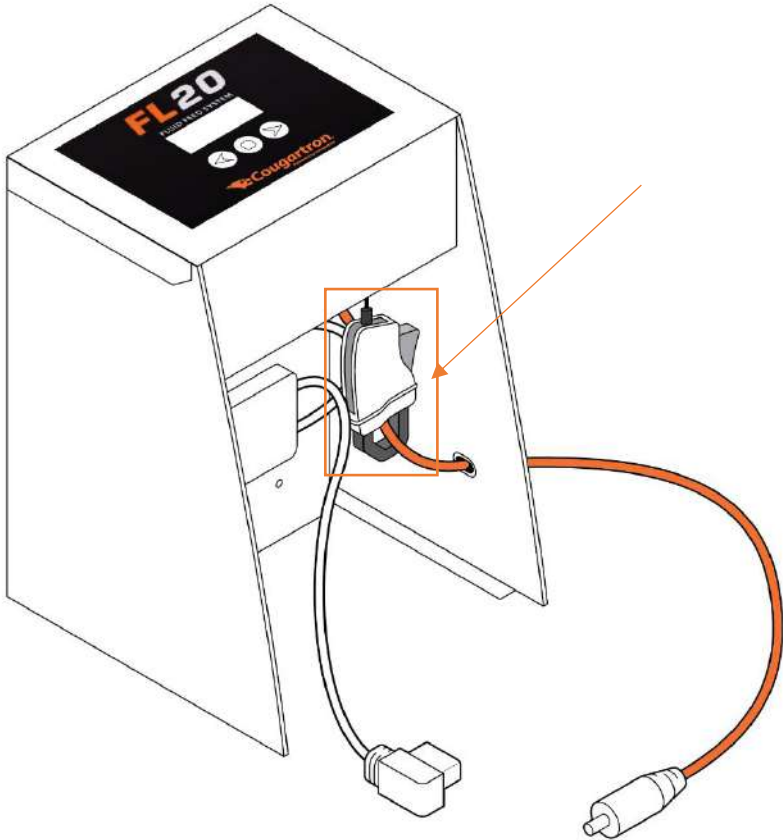

5.3 FL20 Handle and Wand

The handle lead is 4 meters long (13ft), and delivers the fluid to the brush. It is important that fluid connections are not put under strain and are maintained leak free. The handle is insulated from electricity and heat and can be held safely. The wand screws into handle. The

brush tip screws into the wand.

Please ensure that the shroud is always positioned 10mm back from the tip of the brush.

The fluid system should be flushed out with clean water by using the priming setting.

6. Preparation of the FL20

6.1 Preparation Of Weldcleaning Machine

1. 4 threaded inserts need to be screwed into the rear of the machine using the insert tool, as indicated.

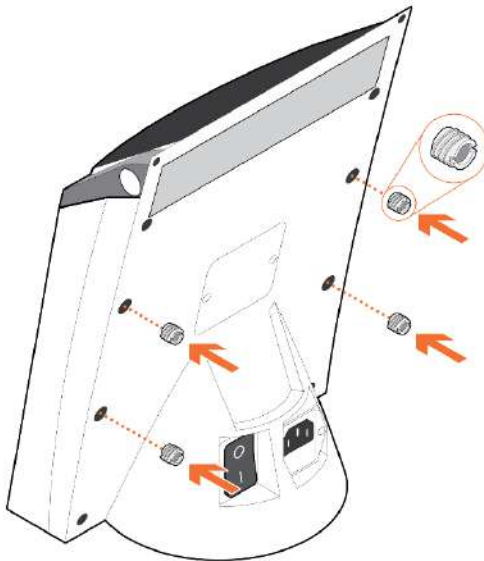

2. It is very important that the slot on the insert is facing out so the insert can be unscrewed for servicing the device

3. Screw the 4 brackets to the back of the machine with the screws provided.

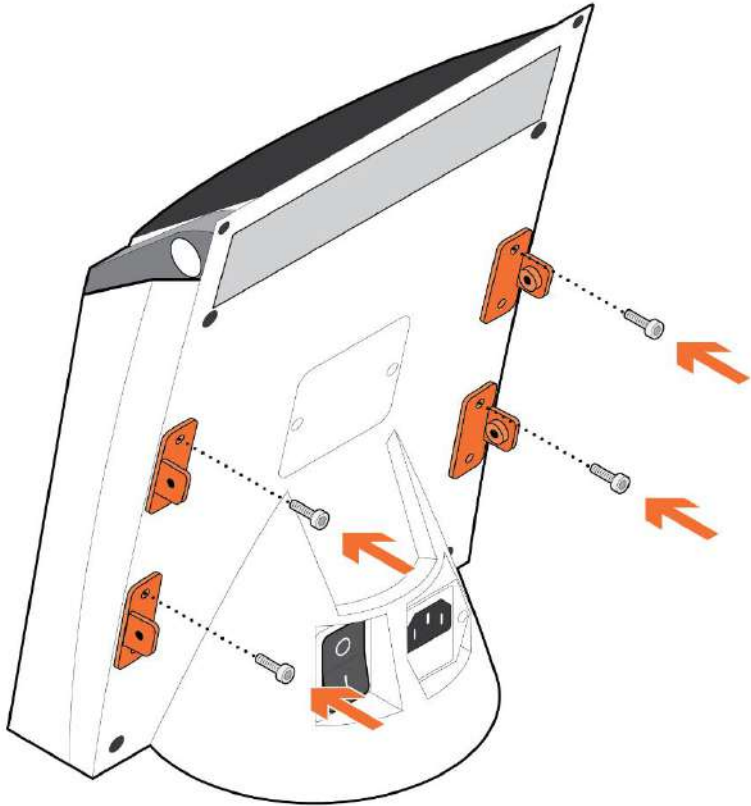

- Using the kettle lead from the FL20, plug in to the back of the weldcleaner and switch on.

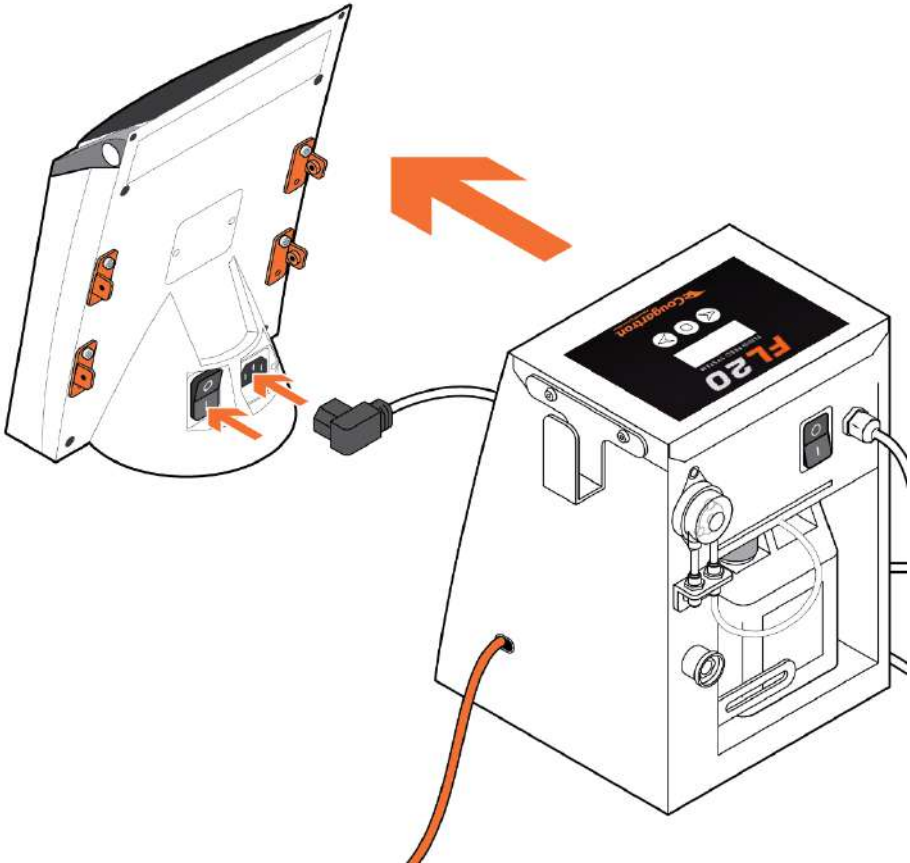

5. Connect the FL20 with 4 screws.

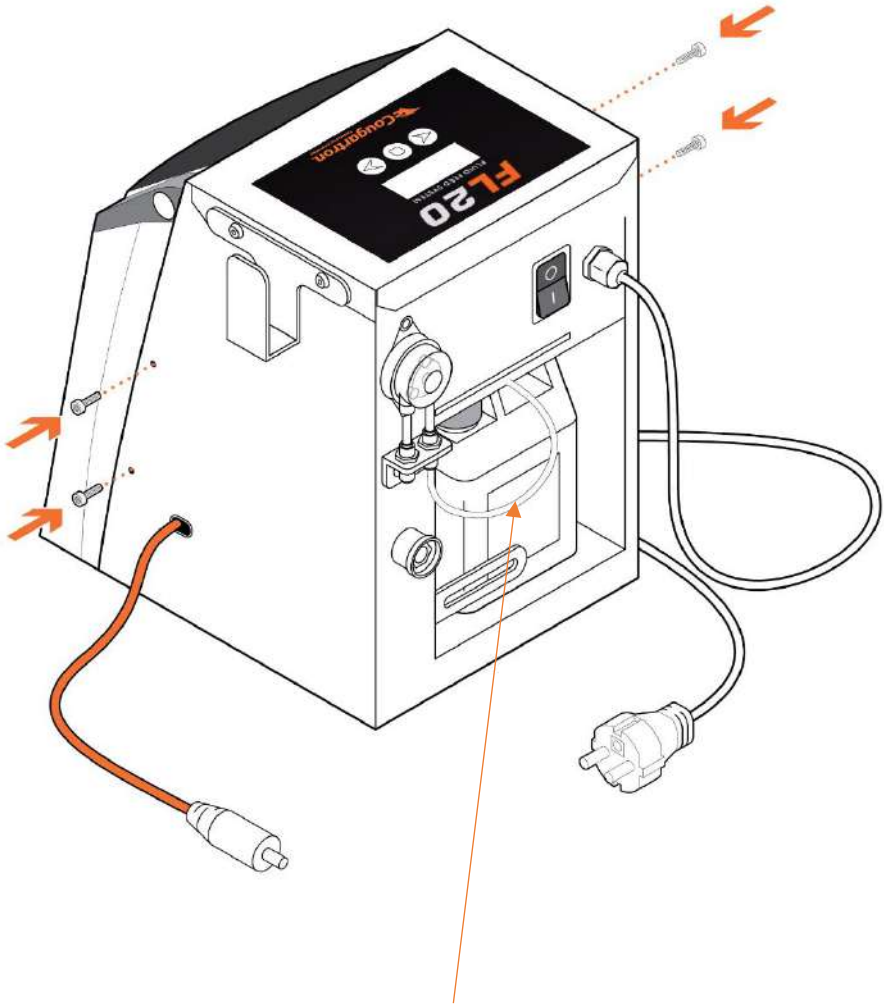

1. The short fluid line needs to be put into the fluid container.

2. The orange lead is plugged into the front of the weld cleaning machine.
3. Connect the fluid feed handle and lead to the rear of the FL20.
4. Screw wand and brush into handle.
5. You are ready to go!

6.2 Cleaning Fluid

We recommend drilling a 4mm hole in the screw on cap of the fluid container and insert the fluid feed line so it is 5mm from the bottom of the container.

6.3 Operation

1. Set POWER control to OFF and plug into mains supply.
2. Turn the ON / Off switch to ON. The setting will be MANUAL 0%.
3. Select PRIMING by press and holding the middle button.
4. 120 secs should be long enough to pump fluid to the brush tip.
5. Select the desired Auto setting.
6. Begin to clean.
7. When desired surface finish is achieved, swap the fluid inlet tube to a water container and turn the setting to priming to flush water through the system.
8. Once complete turn the Cougartron FL20 Power Control to OFF.

7. FL 20 Pump Settings

The below settings are what we recommend;

- Setting 1 for most applications
- Setting 2- 5 to reduce fluid feed unless you are working on a higher amps cleaner.
- Manual setting means fluid is pumped continuously and overrides the current clamp function.

8. Maintenance

- When not in use, ensure the ON /OFF switch is OFF.
- At completion of a work shift, after having rinsed the fluid lines with clean water unscrew the brush from wand. Remove the brush from the insulating shroud and rinse brush, shroud and end of wand with water to remove cleaning solution. Allow to dry before re-assembling.
- Before assembling the brush to the wand, coat threads with copper filled anti-seize compound. This will exclude the acidic solution from the joints and prevent corrosion.
- Rinse clamp with water to remove solution and prevent corrosion.
- Use a wet cloth to wipe fluid splashes off the Cougartron FL20 control unit. After some time, splashes and marks may accumulate and become difficult to remove.

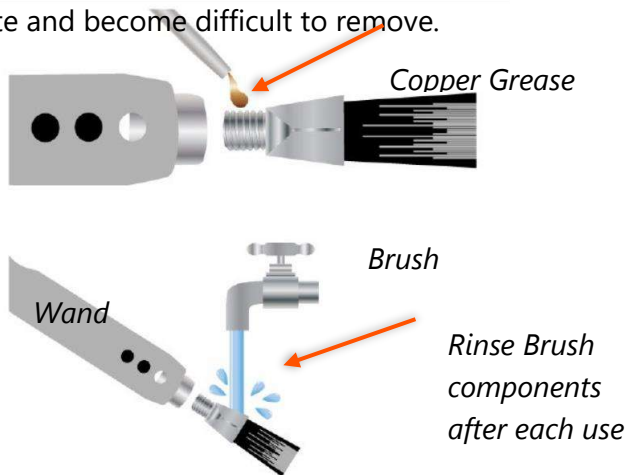

9. Consumables

Consumable supplies are available from authorized Cougartron distributors or directly from www.cougartron.com

9.1 Cougartron Brushes

The brush will wear down with use and should be replaced when the bristles reach approximately 12mm (1/2inch) in length.

9.2 Cougartron Shrouds

The insulating shroud may become damaged or heat affected. If this happens, replacement shroud part nr WELC2460 should be purchased.

9.3 Cougartron Fluids

A range of genuine Cougartron fluids are available. Please check with your local Cougartron distributor for details of fluids available in your region. Types of fluids include:

- **Pre-Weld Cleaning Treatment:** to remove dirt and oil prior to welding to minimize contamination during welding.
Cougartron Wipe'N'Weld – (CW0001) shroud
- **Weld Cleaning Fluids:** for cleaning and /or polishing.
CGT-550 – weld cleaning and polishing fluid (WELC3048)
CGT-350 – weld cleaning fluid (WELC3050)

- **Neutralizing Fluids:** to ensure removal of cleaning fluid residue.
CGT-N5 (WELC3158) or CGT-N1 (WELC3114)
- **Finishing Fluid:** to provide a clean, mark-free finish.
CGT-110 (WELC3049)
- **Marking Fluids:** can be used with stencils to indelibly mark metals.
See our marking fluid range online [here](#).

10. Troubleshooting

If the Cougartron FL20 is not operating correctly, please refer to the following trouble shooting guide before contacting your Cougartron distributor.

10.1 Fluid not delivered but pump turning

- Check all fluid lines and connections for holes and replace as required.

10.2 LCD Display not illuminated

- Ensure the Power Control is ON
- Ensure the power cable is securely plugged into the back.

Contact your Cougartron distributor or visit the website support page for more help at: www.cougartron.com/machine-support

11. Warranty

This warranty is given by:

BM Group International ApS of

Brydehusvej 23, 2750 Ballerup, Denmark,

Tel: +45 4346 2010 Email: warranty@cougartron.com

The benefits given by each warranty set out in this document are in addition to any other rights and remedies you may have under a law in relation to the services or goods to which the warranty relates.

What this warranty covers

This warranty applies to any defects in the goods that appears within 12 months from the date of delivery of the goods to you. To claim under this warranty, the defects must be notified to Cougartron and the goods returned to Cougartron within two weeks of their appearance. Cougartron will, at its option, replace or repair the goods within a reasonable time of receiving a valid warranty claim.

Cougartron will pay for the repair or replacement but you must pay all other costs including all trans- port costs of returning the defective goods to Cougartron and Cougartron delivering the repaired or replacement part back to you.

How to make a claim

If you want to make a claim under your warranty, please contact Cougartron by sending an email to: warranty@cougartron.com

Or submit an online form at: www.cougartron.com/request-machine-repair

You must include your full name, address and contact telephone number and the details of the defect in relation to which you make your claim.

Cougartron will tell you whether you need to return the goods to BM Group International ApS or the approved local distributor.

You will need to return the goods together with all accessories and parts for a full assessment and report.

Additional limitations, exclusions and requirements

This warranty does not extend to:

- consumables such as the brush, insulating shroud and wand,
- any defect caused by normal wear and tear or incidental or inconsequential damage,
- any defect caused by misuse, negligence or other abuse of the goods,
- any defect caused by accidents or alterations,
- goods that have not been cleaned and maintained in accordance with the user's manual supplied with the goods,

- loss or damage, including consequential loss or damage, to your work or facilities arising out of or in connection with the use of the Cougartron Machine, or
- unless otherwise expressly stated, any right to be reimbursed or compensated for physical or financial injury, loss, damage, expense, time or inconvenience (whether direct or indirect) arising out of the occurrence of the defect in the product or your inability to use the product.

To qualify for an exclusive 24-month warranty please go to: <https://cougartron.com/machine-support/> or scan the QR code on the left, and fill out the online form to register your machine.

Scan the QR Code to register
your machine online





Proudly Distributed By:

Machine Serial Number: _____

WWW.COUGARTRON.COM

**WELD CLEANING • SURFACE POLISHING •
MARKING**